

~~III~~
MR. DE LA F. YOUNG.

D 248

ELECTRICAL COMMUNICATION

STANDARD TELECOMMUNICATIONS LABORATORIES LTD.

31 AUG 1966 COPY No. 7

TECHNICAL LIBRARY, HAILLOW

621-326
681-291
65/571



VOLUME 41 • NUMBER 2 • 1966

ELECTRICAL COMMUNICATION

Technical Journal Published Quarterly by

INTERNATIONAL TELEPHONE and TELEGRAPH CORPORATION

320 Park Avenue, New York, New York 10022

President: Harold S. Geneen

Secretary: John J. Navin

CONTENTS

Volume 41	1966	Number 2
This Issue in Brief		118
Data Communication for Industry and Commerce <i>by Martin Jeppsson</i>		121
Three Data-Communication Systems <i>by C.-O. Hendrikson</i>		123
Modem Equipments Complying with International Standards <i>by L. O. K. Edvardsson</i>		131
Modem Equipment for Parallel Data Transmission <i>by B. Lindström</i>		139
Special Measuring Equipments for Data Transmission <i>by B. Lindström</i>		149
Error Detection and Correction in Low-Speed Data-Transmission Equipment <i>by H. Sauer</i>		154
Dynamic Measurements of Magnetic Thin Films <i>by J. M. Tyska</i>		161
Memory for Test and Evaluation of Magnetic Thin Films <i>by J. M. Tyska</i>		167
Data Transmission—Current Trends and Future Prospects <i>by J. W. Halina</i>		177
Instrument Low-Approach System and Radio Altimeter for All-Weather Landings <i>by W. L. Garfield and F. T. Norbury</i>		196
World's Telephones—1965		216
United States Patents Issued to International Telephone and Telegraph System; February–April 1965		223
Recent Achievements		226
Notes		
ITT Receives Meteorological Award		120
Book: Modulation, Noise, and Spectral Analysis		215
Book: Mathematik für Elektrotechniker (Mathematics for Electrical Engineers)		215

Copyright © 1966 by INTERNATIONAL TELEPHONE and TELEGRAPH CORPORATION

EDITOR, Harold P. Westman

ASSISTANT EDITOR, Melvin Karsh

Subscription: \$2.00 per year

50¢ per copy

Three Data-Communication Systems—The chief considerations in data communication are speed, error detection and correction, and the kinds of input and output equipment used.

Data-communication system *GH-201* for 600 to 1200 bits per second is equipped with fully automatic error detection and correction and is adaptable for use with various input and output equipments. Data-communication system *GH-403* for 75 characters per second is equipped with error detection and correction, and is also adaptable for use with various input and output equipments. Data-communication system *GH-101* for 10 characters per second has no error detection and correction, and is adapted for use with the Teletype *T33* teleprinter.

Modem Equipments Complying with International Standards—The demand for civil data communication has increased rapidly during recent years, with the result that a number of international organizations are now carrying out intensive studies on standards. The International Telegraph and Telephone Consultative Committee has issued a number of recommendations for transmission of data in serial mode.

The paper describes two frequency-modulated modem equipments for transmission of data in serial mode, the *GH-2002* for signaling rates up to 1200 bits per second, and the *GH-1101* for signaling rates up to 200 bits per second. Both are in accordance with recommendations of the International Telegraph and Telephone Consultative Committee.

The *GH-2002* can be equipped with a supervisory channel for simultaneous signaling in the reverse direction with rates up to 75 bits per second. Clocks for synchronous operation at 600 and 1200 bits per second, as well as signal-quality detectors for error detection and an envelope delay equalizer, can be included. A number of line-unit options are given for operation on switched or private 2- or 4-wire lines.

The *GH-1101* is intended for full-duplex operation over 2-wire circuits only.

Modem Equipment for Parallel Data Transmission—In data-collection applications over switched telephone networks, data must often be transmitted from a large number of outstations to a central station. It is then of great interest to reduce the cost of the outstation as much as possible, even at the sacrifice of transmission speed.

A modulation system is described by which the data signals are accepted in parallel form and transmitted in a 4-out-of-16 frequency code. By this principle the modem equipments can be easily adapted to various input/output media such as punched tape, punched cards, et cetera.

In its least costly form the system transmits all characters interlaced with rest-condition signals; data transfer rates up to 25 characters per second can thus be achieved. If equipped with an optional timing channel, the system is capable of transmitting 8-bit characters at any transfer rate up to 75 characters per second.

A backward channel is provided by which it is possible to transmit supervisory signals from the central station to the outstation.

Special Measuring Equipments for Data Transmission—The rapidly increasing use of data-transmission systems has intensified the need for suitable measuring equipments for research and development as well as for factory testing and maintenance. The error-rate analyzer Era has been manufactured in quantity and sold to several countries. It is designed for looped or point-to-point measurements on a synchronous basis at modulation rates ranging from 25 to 3000 bits per second. The built-in clock signal generator supplies 24 crystal-controlled signaling rates that permit measurements between widely separated terminals.

Element-error rates as well as mutilation disturbances and various kinds of time distortion can be measured. Time distortion is measured on a digital basis. The setting accuracy is 0.5 percent in the low-speed range and 5 percent in the medium-speed range.

Error Detection and Correction in Low-Speed Data-Transmission Equipment

Two equipments for error detection, operating with decision feedback on low-speed half-duplex telegraph connections, are described. Error detection is achieved by putting the information to be transmitted into a feedback shift register at the sending station as well as after reception at the receiving station. The check signals formed in the two shift registers are then compared. With coincidence, transmission goes on, otherwise the erroneous block is repeated.

The information is transmitted in blocks, the manual system operating with any selected block length and the automatic system with fixed block length.

The manual system *GH 111* is intended for operation at 50 bauds. The automatic system *GH 110* can be switched to operate at 50, 75, 100, or 200 bauds.

Both systems improve the error rate by 4×10^3 ; that is, with 8 hours service per day at 50 bauds, an error now occurs only once per year.

Dynamic Measurements of Magnetic Thin Films

—A dynamic-measurement apparatus called the creepmeter makes it possible to test plane areas of magnetic thin films not equipped with access conductors, under conditions simulating real operation in a memory. It measures with very-good accuracy the dispersion angles, output characteristics, and sensitivity to the creep effect.

Memory for Test and Evaluation of Magnetic Thin Films

—A very-fast memory of small capacity (64 words of 16 digits) has been built to evaluate thin-film memories. It has also proved to be highly effective for measuring the performances of the films prepared in Laboratoire Central de Télécommunications.

The memory is characterized by excellent compensation of the stray signals by means of

balanced pulse transformers (average rejection rate, 50 decibels), which permits reaching very-high working speeds (access time, 60 nanoseconds; cycle time, 150 nanoseconds). Particular care is given to the problem of reliability, and especially to the creep effect: the memory showed no failure when subjected to 10^{10} disturbing pulses in a worst-case configuration.

Data Transmission—Current Trends and Future Prospects

—The seed of today's Cybernetic Revolution was sown with Watt's invention of a governor for steam engines. The revolution got its name from Norbert Wiener as the title of his now-famous book published in 1948. The consequence of it all to communications comes under the title of data transmission. Today virtually no management and control operation in commerce, government, or science is immune to the introduction of computing machinery to aid man's mastery of his environment. Computers communicate in machine language in digits—with data.

By the nature of the arithmetic of information, the quantity of messages tends to rise as the square of the number of interacting terminals. Thus data transmission will tend to achieve a rate of growth which is two times that of its digitally communicating terminals. The transmission facility to accommodate these new loads, together with the natural growth of classical telephone traffic, is the one designed and built for voice communications. The world's telephone plant represents an investment in excess of \$30 billion. The central problem is therefore the expansion and modification of this plant in such a way that its capability for data transmission may be compatible with its voice transmission facilities.

The article is a comprehensive discussion of the problem, past experimental solutions, and avenues for future development.

Instrument Low-Approach System and Radio Altimeter for All-Weather Landings—The economic necessity to maintain scheduled flight services with modern jet aircraft under conditions of poor visibility has accelerated the program to automate the landing phase.

One of the most prominent postwar automatic landing systems was that devised by the British Blind Landing Experimental Unit (*BLEU*). It uses a radio altimeter to provide height guidance information and electromagnetic leader cables for azimuth guidance. Many thousands of successful landings have been accomplished using this system, which is in operational use for military aircraft.

More recently it has been established that the modern improved localizer of the instrument

low-approach system is accurate and stable enough to serve as the sole guidance facility for approach, landing, and roll-off down the runway, rendering leader cables unnecessary. Such instrument landing systems, now in operational use at many major United Kingdom and European civil airports, are presently being evaluated for compliance with the Category II requirements of the International Civil Aviation Organization.

Radio altimeters used in all-weather landings must have full failure survival. Usually two are used with cross-comparison. Opinions differ whether the scale between 0 and 500 feet (150 meters) should be logarithmic or linear. Radio altimeters are in operation that are accurate to within ± 3 percent and within ± 1 foot (0.3 meter) at touch-down.

ITT Receives Meteorological Award

Its Award for Outstanding Service to Meteorology for the development of a device that provides for the first time detailed pictures of the clouds above the earth at night was conferred on International Telephone and Telegraph Corporation by the American Meteorological Society early in 1966.

The award was accepted by R. T. Watson, President of ITT Industrial Laboratories Division, in which the space camera was developed. This achievement is described in *Electrical Communication* in a paper "Infrared and the Nimbus High-Resolution Radiometer" appearing on pages 500–507 of volume 40, number 4, 1965.

Data Communication for Industry and Commerce

MARTIN JEPPSSON

Standard Radio & Telefon AB; Barkarby, Sweden

The economic advantages of large-scale manufacture have resulted in the concentration of manufacturing effort on products suited to mass production. This mass production and distribution of goods and services has resulted in the mass production and consumption of data. During recent years the use of machine techniques for storing and processing large quantities of data has grown at an ever-increasing rate. Industry and office vie with each other in their efforts to utilize the new developments in electronics for the rationalization and automation of their work processes.

Before the advent of the electron data processing era, the problems of collection and transport of data received relatively little attention as these problems were overshadowed by the difficulties of processing and storing. However, the capabilities and large capacity of present-day data processors make a practical method of transmitting data essential. As a result, telecommunication techniques have come to play an important role, and data transmission over telecommunication circuits is now an established fact. For many years it has been possible to hire permanent telegraph channels or connections within the telex network. More recently however, much development work has been proceeding in various countries to make it possible to similarly use the transmission capacity and capabilities of the telephone network for the transmission of data.

The ability to transmit data at high speeds has done much to improve communication within organizations and enterprises. An organization having factories and offices at widely separated places, perhaps in different countries, can be made much more effective by the use of data transmission. When the communication problem is solved satisfactorily, centralization, or decentralization if such be the required solution, can be introduced without regard to the prevailing geographical conditions.

If all the data processing can be carried out at one data center, it is possible to use one large data processor, instead of a number of smaller

ones. This can result in a significant economic gain, as the relative operating cost of a large machine is considerably less than for several small machines. The central machine can be used by each unit of the enterprise that has direct access via the data terminal. This method of operation via telecommunication circuits is referred to as terminal data processing. In many cases the individual enterprise units are not sufficiently large to warrant the installation of separate data machines. Terminal data processing provides an economic solution also for such enterprises.

If an organization has two or more separate data processing centers, data transmission can be used to distribute the load among the various machines. For example, a service organization may set up a number of data centers in different places. The unused capacity of one data center can quite easily and quickly be put at the disposal of another center.

The use of data transmission for the transport of data can result in increased reliability. Cases have occurred where the physical transport of the data medium has resulted in serious inconvenience. In one case, for example, a very large number of punched cards were strewn over a wide area as a result of a car collision.

Data transmission improves customer service. The time taken to expedite an incoming order can often be reduced and the goods can be delivered more quickly. In addition, all types of inquiries can be answered more rapidly. This is of particular importance when it is desirable to give the customer information over the counter or during the course of a telephone conversation. A well-known example of this is the system employed by several airline companies for advance booking. Each advance-booking bureau is in contact with a central data processor and within a matter of seconds can obtain information from the machine regarding available accommodations. To provide such a high-speed service, the data machine must be in direct contact with the data transmission system. This is referred to as an on-line connection.

Data Communication for Industry

In the United States of America it has been predicted that the data traffic via the telephone network will increase so rapidly that in the near future this data traffic will be substantial compared with the telephone traffic. It has also been forecast that in 10 years fully half of all data processing will be done by remote terminals and giant computers.

As regards the development of data transmission, Europe is a year or two behind America, and of all the European countries only Great Britain, Sweden, and Norway have progressed so far that their telecommunications administrations are in a position to offer modem equipments to potential data transmission subscribers. However, in many other countries, intensive preparatory work is being undertaken. It should not be very long before many more telephone administrations are in a position to offer data transmission service, and in the meantime it is possible, in general, for potential customers to obtain permission to connect their own equipments.

Article 4 of the International Telecommunications Convention requires the International Telecommunications Union to maintain and ex-

tend international cooperation for the improvement and rational use of telecommunications of all kinds. It must promote the development of technical facilities and their application to improving the efficiency, usefulness, and general availability of all telecommunications services.

The International Telegraph and Telephone Consultative Committee (CCITT), which is an organ of the International Telecommunications Union, develops standards for transmission channels, be they leased or switched, and for necessary signal conversion terminal equipment. It cooperates with other international bodies on standards for interfaces of data terminal equipments, data alphabets, and error control procedures. A large number of relevant subjects have been studied and some valuable progress has been made over the past 7 or 8 years. The difficulty of reaching agreement among the many interested member organizations has been a limiting factor in a number of areas.

The following articles describe the equipments developed by ITT Europe to meet the needs of a data transmission system and the ancillary apparatus necessary to test and maintain it.

Three Data-Communication Systems

C.-O. HENRIKSON

Standard Radio & Telefon AB; Barkarby, Sweden

1. Introduction

The various applications of data communication have created the need for a family of data-communication systems having different technical features. It is desirable, naturally, to have a standard system that can be equipped in different ways to give the optimum solution for each application, with regard to both cost and technical features. However, a system having the required flexibility will often increase the cost of the equipment for all the different configurations. It is therefore more economical to cover the requirements with a number of different types of systems.

This article describes 3 completely different types of systems intended for different applications. Two of the types consist of a number of compatible data-communication terminals that make it possible to transmit between different types of data media, such as paper tape, punched cards, magnetic tape, and printers. These types of systems can also be easily arranged to operate with on-line computers. The third system is specially designed to operate with the Teletype T33 teleprinter equipment, which is equipped with a printer with manual keyboard, a paper-tape reader, and a tape punch. However, this system can also be connected to other equipment, for example a computer. All 3 systems are intended for use over 2-wire or 4-wire circuits in the telephone network.

Data-communication terminals are often installed at widely separated places, and this can quite easily lead to maintenance problems. Therefore, it is extremely important that the highest possible reliability be attained. The choice of peripheral equipment is of particular importance as, in general, this type of equipment requires more maintenance than purely electronic equipment. The maintenance costs of the systems described here have been reduced to a minimum by the use of reliable components and conservative dimensioning of the various circuits. For example, with very few exceptions silicon transistors and diodes have been used throughout. It is not often possible to repair

such equipment on site, and it is therefore necessary to replace any circuit unit which has developed a fault. To simplify such replacement the equipment has been constructed of separate plug-in functional units.

2. Medium-Speed Systems

The two different systems described here are both intended for use over switched or leased telephone circuits. They are equipped with fully automatic error-detection and -correction devices using the same technique. Error detection takes place at the receive terminal and error correction is carried out by repetition. A narrow-band low-speed backward channel is used for sending the retransmission request back to the send terminal. One of the systems (*GH-201*) makes use of the 600-to-1200-baud modem recommended by the International Telegraph and Telephone Consultative Committee, whereas the other system (*GH-403*) utilizes a parallel-type modem equipment.

2.1 DATA COMMUNICATION SYSTEM *GH-201*

The development of the *GH-201* system was begun in 1961 after a preliminary investigation that gave extremely promising results. In the early stages of the development, the Swedish Telecommunications Administration had already begun to take an active interest and ordered a prototype system for further tests under their own control. The data systems that were available at that time were not considered suitable for use over the public telephone network. In general, too much emphasis had been put on the development of the digital parts of the equipment without regard to the difficulties likely to arise because of the special characteristics of the telephone network. A thorough investigation of the error rate on the telephone network had been carried out in different countries before development work on the *GH-201* began, so that the error rate and error distribution were already well known.

Three Data-Communication Systems

The new approach to the error-correction problem was, figuratively speaking, to integrate the error-correction equipment, the modem equipment, and the telephone line in one unit. This means that all the information available within this unit can be used for error detection. For example, disturbances in the line signal can easily be detected in the modem equipment and give rise to an error indication. A great advantage with such a system is that errors are detected at the same time as they occur. Hence error correction can be arranged to take place immediately, and the need for a large storage to cover the time between error detection and error correction can be avoided.

The first prototype of a system constructed in accordance with these principles was completed in 1962. The system has been tested both in the laboratory and in the field, among others by the Swedish Telecommunications Administration, with particularly good results. The system has also evoked much interest within the International Telegraph and Telephone Consultative Committee. A report that includes the results of measurements has been submitted by the Swedish Telecommunications Administration, and the method for error detection and correction has been recommended for further study.

2.1.1 Terminal Configuration

The *GH-201* system is intended as a versatile flexible system for use with various peripheral equipments or directly connected to computers.

The build-up of a typical system is shown in Figure 1. The basic units (modem and logic equipment) are common to all versions of the system, whereas the matching equipment and control units that are installed depend on the application for which the system is to be used. It has been possible to simplify the matching equipment by giving careful thought to the design of the logic equipment, and thus it is an easy matter to construct a special matching unit for a particular application. The character-by-character method of data transmission also helps in this respect.

Data-transmission systems are, in general, in the charge of office personnel who have not received any special education in this particular field. It is therefore extremely important that the operation of the system be as easy as possible. On the other hand the number of facilities required demands that the system be made flexible and that fault finding be as simple as possible. The *GH-201* control facilities can be divided into two groups. One group includes a few facilities that are used with the routine op-

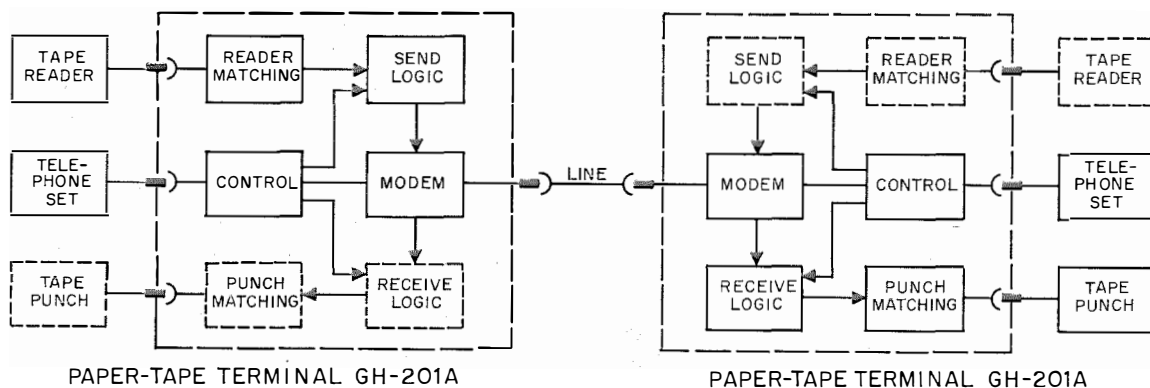

Figure 1—Block schematic of *GH-201* data-communication system.

eration of the system, and the other group includes those facilities that are only used on special occasions. This latter group includes aids to the location of certain types of faults, in-and-out connection of the automatic answering facility, selection between automatic and manual disconnection, and loop connection for copying or fault tracing.

The amount of work involved in connecting the data equipment in and out of the circuit can be considerable if the traffic intensity is relatively high. This applies particularly in data collection, where one operator can be required solely for this operation. For this reason the standard versions of the *GH-201* terminal have been equipped with automatic disconnect facilities. In addition, the terminal has been provided with an automatic answering facility that automatically connects the data equipment when the terminal is called.

The basic equipment of the system is mounted in a floor-standing cabinet as shown in Figure 2. All the equipment required for alternate 2-way traffic can be assembled in the same cabinet. The telephone set is usually placed on top of the cabinet and, when provided, the peripheral equipments are contained in a separate cabinet. The control devices and the indicator lamps required for the operation of a complete system are mounted on a removable panel fitted in the top part of the cabinet. The individual components are mounted on plug-in printed-wiring boards assembled in subracks. If a functional unit takes up more than one of these subracks, all the subracks that make up the unit are mounted together so as to form one complete interchangeable unit. Each functional unit is connected by means of plug-and-socket connectors, so that it is easy to replace a faulty unit.

The modem equipment used in the system has the code *GH-2002*. This modem is equipped with a data channel for 600 to 1200 bits per second and a supervisory channel for 75 bits per second and conforms with International Telegraph and Telephone Consultative Committee recommendations.

2.1.2 Error Detection and Correction

A unique combination of an analog and a digital method is used for character error detection. The digital error detection is carried out with the help of a double-parity control as shown in Figure 3. The method used for this control has been chosen so that the maximum error-detection capability is obtained in conjunction with the analog error-detection circuits (signal-quality detectors), which are included in the modem equipment. Any disturbance must be spread over at least 3 signal elements if it is to remain undetected by the parity control. However, all disturbances of such length will easily be detected by the signal-quality detectors, in which the received line signals are supervised and which cause an error indication to be made each time a predetermined threshold value is

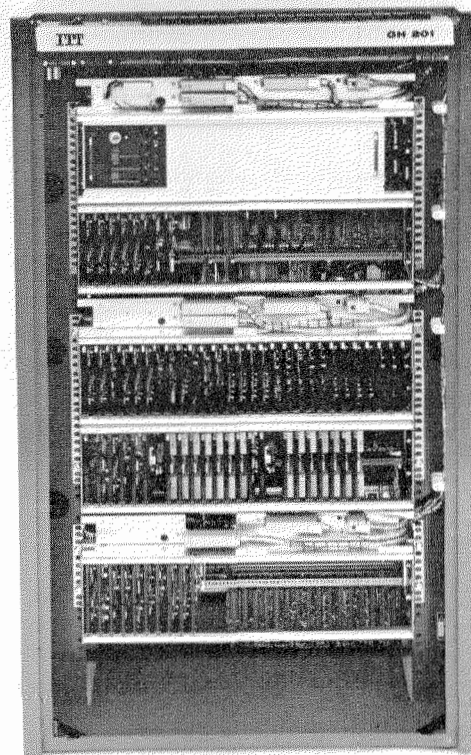

Figure 2—*GH-201*, typical functional unit.

Three Data-Communication Systems

exceeded. Practical tests have indicated that the ability of the signal-quality detectors to detect errors is extremely good. Very few errors occur that do not give rise to an error indication; tests have also shown that all such undetected errors were detected by the parity control. Hence there is every justification for saying that almost errorfree transmission of data is possible when using the *GH-201* system, even in cases where the transmission circuit is subject to serious interference.

The incoming data can be continuously controlled if the characters in the data source fulfill a parity condition (odd or even). Thus, for example, any reading error from the punched tape or magnetic tape can be detected immediately. An alarm is received from the system control panel each time an error occurs.

Error correction is carried out by retransmitting the data, which has been stored at the send terminal. When an alarm is obtained from the parity control or the signal-quality detector in the receiving terminal, a request for retransmission is sent back to the sending terminal via the supervisory channel. The supervisory channel is also equipped with a signal-quality detector, and every alarm from this detector is also interpreted as a request for retransmission.

In a system that employs the retransmission method of error correction, the required capacity of the memory at the send terminal depends on the maximum delay time between the sending of a character and the beginning of the retransmission of the same character, in the event a retransmission is necessary. In the *GH-201* system it has been possible to make this delay time short, and consequently the memory requirement is small. As a result of the use of character-by-character transmission, the occurrence of an error and its detection take place almost simultaneously. This also applies to the reception of a request for retransmission and the start of the retransmission.

It is also possible to avoid delay between the detection of an error and the sending back of the request for retransmission, because the data

channel and the supervisory channel are working on a full-duplex basis. The maximum time delay between the sending of a character and the beginning of a requested retransmission of the same character, is therefore more or less equal to the sum of the data channel and the supervisory channel transit times. The standard capacity of the memory in the send terminal is 16 characters, which allows a total delay time of 65 milliseconds at 1200 bits per second and a transmission code of 9 bits per character. The capacity of the memory can be increased quite easily by adding extra memory units. A memory capacity of one character is all that is required in the receive terminal to ensure a clean-copy output.

The time efficiency of a data-communication system is mainly dependent on how the request for retransmission goes back to the send terminal, how much data are retransmitted with each retransmission, and how much redundancy is added to the information. In the *GH-201* system transmission takes place without interruption when no errors occur, because the supervisory channel is working on a full-duplex basis with the data channel. As explained previously, the amount of data that must be retransmitted with each retransmission is limited to the amount required to cover the sum of the go and the return transit times. In this way it has been possible to maintain high transmission efficiency even with poor-quality transmission lines.

2.1.3 Information and Transmission Code

The system is completely independent of alphabet and character representation. The characters may contain between 4 and 8 bits, but in the case of 8-bit characters an odd or even parity condition must be fulfilled. The length of the transmission code must be selected with regard to the maximum speed of the peripheral equipment to be used. The minimum length of the transmission code depends on the information code. If the information code includes 1 parity bit, the minimum length of the transmission

code will be the information code plus 1 bit. If no parity bits are included the minimum length will be the information code plus 2 bits. The maximum length of the transmission code is 9 bits. The length of the code is determined with the help of interchangeable circuit boards in the send and receive logic.

When the chosen length of the transmission code exceeds the minimum length required by the information code, dummy bits are automatically added in the send logic and separated in the receive logic. This means, for example, that 8-channel and 5-channel paper tape can be sent alternately without making any changes in the system.

The transmission of a message, which can be of variable length suitable to the peripheral equipment, is preceded by a start-of-message code and ended by an end-of-message code. The former is also used as a character synchronization signal.

2.1.4 *GH-201 Paper-Tape Terminal*

The *GH-201* paper-tape terminal provides facilities for the rapid and completely reliable transmission of 4-channel to 8-channel paper tape. The reading speed can be as high as 200 characters per second, but the punching speed is limited to 133-1/3 characters per second. Transmission from paper tape to paper tape is therefore limited to the slower speed. However, paper tape can be transmitted at 3 faster speeds (150, 171-3/7, and 200 characters per second) on the assumption that the receive terminal is connected to an output medium having the necessary speed. All the equipment required for alternate 2-way traffic (with the exception of the tape punch and tape reader) is mounted in the previously mentioned floor-standing cabinet shown in Figure 4.

2.1.5 *GH-201 Printer Terminal*

The *GH-201* printer terminal provides facilities for reception of data with hard-copy output from an on-line printer. The terminal can also

be equipped for paper-tape input. The maximum printing and reading speed is 200 characters per second.

2.1.6 *GH-201 Standard Interface Terminal*

In data communications there is often a need for special peripheral equipments. The reason

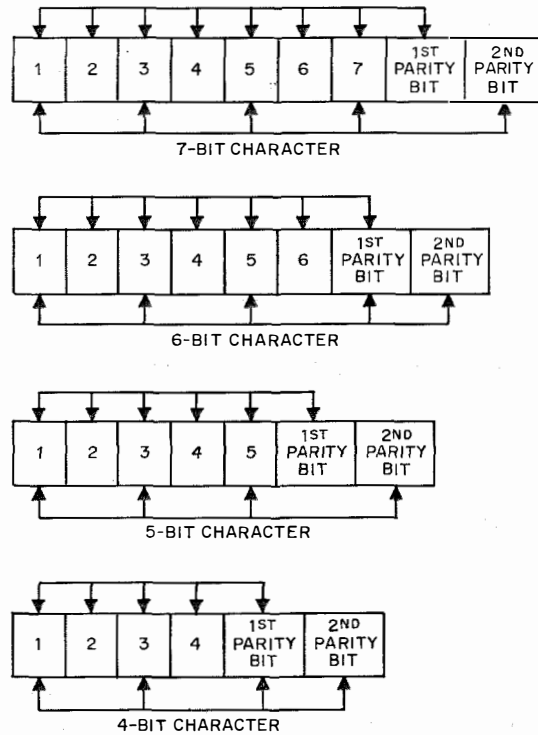

Figure 3—*GH-201*, parity check method.

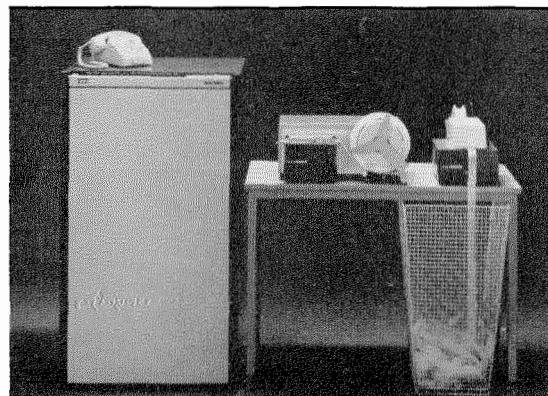

Figure 4—*GH-201* data-communication terminal.

Three Data-Communication Systems

might be that a complete data-processing system requires special equipment or that the supplier of a system desires to use the same peripheral units throughout. The supplier of the data-communication equipment can hardly undertake to manufacture matching equipment for all types of peripheral equipments. A standard interface providing facilities for easy connection of as many different peripheral units as possible is therefore supplied with the *GH-201* system. The interface is of parallel type and operates in a character-by-character mode.

2.2 Data-Communication System *GH-403*

The *GH-403* data-communication system is intended for 1-way traffic at rates up to 75 characters per second. The system is designed mainly for data collection. In this application each of a number of outstations collects a relatively small amount of data, which must be sent to 1 instation, for example at a data center. Hence it is desirable that the outstations be as simple and inexpensive as possible. As a result the instation has become somewhat more expensive, but as only 1 or, at most, a very limited number of instations are needed, they will not affect the overall price of the system to any great degree.

Considerable savings are achieved in the cost for modem equipment by making use of parallel-mode transmission. The type of modem used at the send terminal is coded *GH-4002C* and at the receive terminal is coded *GH-4002B*.*

* B. Lindström, "Modem Equipment for Parallel Data Transmission," *Electrical Communication*, volume 41, number 2, pages 139-148; 1966.

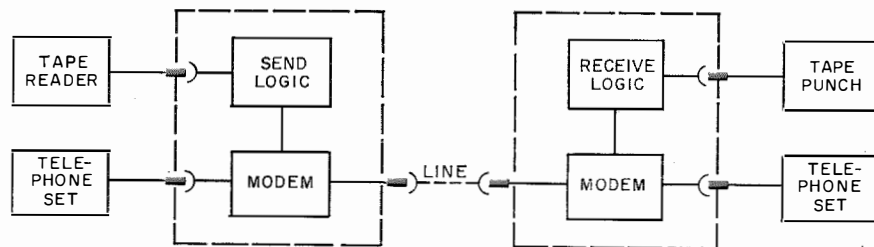

Figure 5—Block schematic of *GH-403* data-communication system.

The system is equipped with fully automatic error detection and correction working on a character-by-character basis. Simple error detection, similar to the one used in the *GH-201* system, does not require any extensive coding of the information in the send terminal.

The receive terminal is equipped with an automatic answering device, which can be used if desired to connect the data equipment to the telephone line automatically when a call is received. The circuit is disconnected after completion of the data transmission. The choice between automatic and manual connection of the data equipment is made with the help of a switch at the receive terminal. As an additional safety precaution the terminal is provided with an automatic disconnect facility, which comes into operation 1 minute after connection is made if transmission has not commenced in the meantime.

2.2.1. Terminal Configuration

The system is primarily designed for paper-tape equipment but the receive terminal can easily be connected directly to a computer. Figure 5 is a block schematic of the two terminals.

All the circuits in the system are mounted in cabinets. The send terminal is a desk-top model and the receive terminal a floor-standing model.

2.2.2 Error Detection and Correction

For error detection a combination of a simple parity check and signal-quality supervision is used in the modem. To avoid the cost of coding circuits in the send terminal the parity bit, odd

or even, must be supplied on the tape. In case of a parity error or an alarm from the signal-quality detectors in the receive terminal, a repetition request is sent back to the send terminal. The paper tape in the reader is stepped back to the desired place, whereupon retransmission takes place. At the receive terminal provisions are always made for clean-copy output.

3. Low-Speed Systems

Many data-communication applications do not require a higher speed than 10 characters per second. This need can often be fulfilled with standard telex equipment but in some cases the limitations of telex force other solutions. The two severest limitations—the 5-unit code and the absence of error-control equipment—can be avoided with the two systems described by H. Sauer in this issue.

3.1 DATA-COMMUNICATION SYSTEM *GH-101*

From the point of view of the user, the *GH-101* system is very much like telex. The main differ-

ences are that the system is used over the telephone network, that the 7-unit code has been adopted, and that the speed is increased to 10 characters per second. This system is equipped with the *GH-1101* type of modem equipment, which is a 200-baud both-way modem in accordance with recommendations of the International Telegraph and Telephone Consultative Committee.

3.1.1 Terminal Configuration

The system is designed round the Teletype *T33* teleprinter. However, it is also possible to connect the receive terminal directly to a computer.

The *T33* consists of a teleprinter to which a paper-tape reader and punch can be connected. The machine is available with or without keyboard. The length of a row is 72 characters with 10 characters per inch. The teleprinter is constructed as a floor-standing model as shown in Figure 6. All the necessary equipments, including the modem, are mounted in the teleprinter frame.

3.1.2 Information and Transmission Code

The information code used corresponds to the "American Code for Information Interchange" (ASA X3.4-1965). This code contains 7 information bits per character plus 1 parity bit (even parity). The transmission code consists of the information code plus 1 start bit and 2 stop bits, and thus contains a total of 11 bits. Hence the data-transfer rate of 10 characters per second corresponds to a signaling rate of 110 bits per second.

4. Conclusion

Different types of data-communication systems are often compared on the basis of cost per transmitted character. When assessing the total costs in such cases, it is normally the practice to include only the cost of the terminal equipment and the cost of the circuit during the time that transmission takes place. The results of

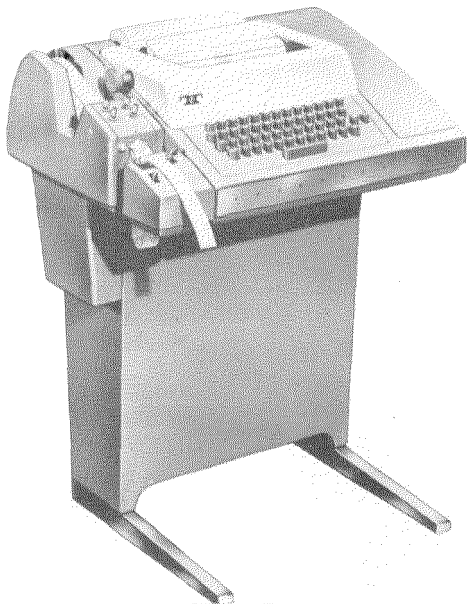

Figure 6—*GH-101A* data-communication terminal.

Three Data-Communication Systems

such comparisons usually indicate that the terminal-equipment costs are decisive, giving the impression that cheap systems with a relatively low transmission speed are the most economical. However, comparisons carried out on such a basis are misleading to a high degree. Any cost comparison must of course consider the system as an integral part of a data-processing system, so that, for example, the costs of disturbances in the data-processing routine, the cost of the equipment that is brought into use during transmission, and the operation and maintenance costs must all be taken into account. In the main, disturbances in the data-processing routine are caused by received data errors that are not detected before the data goes into the data processor. The cost of correcting such errors not only includes the cost of the actual correction, but also the cost of the resultant delay in the data processing. In a large data center, where very often the data processing must keep to a carefully planned time schedule, any delay of this nature can be quite damaging.

A system cost comparison, which takes into account the various items mentioned above, can lead to the result that the system that is the most expensive to purchase can nevertheless

prove to be the least expensive in the long run. It is not possible to say that any particular type of system is the most economical under all circumstances, and each particular application must be carefully considered on its merits.

The systems described in this article provide an answer to the demands for data communication over the public telephone network. The flexible construction of these systems simplifies their adaptation for use with different types of input and output media, and hence it is possible to satisfy the requirements of any particular application, bearing in mind the limitations imposed by the telephone network.

Carl-Olof Henrikson was born in 1933. He received an MS degree in electrical engineering in 1960 from the Royal Institute of Technology, Stockholm.

He joined the Transmission Division of Standard Radio & Telefon in 1960 and is now responsible for development and technical application of data-communication systems.

Mr. Henrikson is a member of the Swedish Association of Engineers and Architects.

Modem Equipments Complying with International Standards

L. O. K. EDVARDSSON

Standard Radio & Telefon AB; Barkarby, Sweden

1. Introduction

The demand for civil data communication has increased rapidly during recent years, with the result that a number of international organizations are now carrying out an intensive study of standardization problems. The work undertaken by the International Telegraph and Telephone Consultative Committee has now reached the stage where a number of recommendations have been prepared for transmission of data in serial mode. As a result of our experience in the military data-transmission field, Standard Radio & Telefon have been able to actively assist in the standardization work, and, since the formulation of the recommendations of the International Telegraph and Telephone Consultative Committee, have been able to introduce various modem equipments for nonmilitary applications.

Three types of equipment having the codes *T1J*, *T2J*, and *T2K* were developed during 1961 and 1962. *T1J* is designed for signaling rates up to 1200 bits per second. *T2J*, which is also designed for these signaling rates, includes a supervisory channel for 75 bits per second. Both of these types of equipment are arranged for reversible 1-way traffic over 2-wire lines or, alternatively, for both-way traffic over 4-wire lines. *T2K* is intended for both-way traffic over 2-wire lines with signaling rates up to 200 bits per second. Since their inception these three types of equipment have been tested in a number of countries and the results have been very good in all cases. In Sweden any of these three types can be hired from the Telecommunications Administration.

ITT Europe recently introduced an improved system of mechanical construction based on printed-wiring boards mounted in subracks.* This equipment practice, which has been carefully and thoroughly tested, has proved to have considerable advantages over the earlier construction, in which components were mounted

on chassis plates. It was therefore adopted for the mechanical construction of all types of modem equipment intended for nonmilitary applications. This conversion at the same time made it possible to modernize both the components and the circuit design of the equipment. Our new versions have been given the codes *GH-2002* and *GH-1101*, the former replacing the *T1J* and *T2J* types of equipment, and the latter replacing the *T2K* equipment. Only the new types of equipment are described in this paper.

2. Modem Equipment, *GH-2002*

The modem equipment, type *GH-2002*, is intended for data transmission with signaling rates up to 1200 bits per second. It can be equipped with units to provide a number of special facilities, such as a supervisory channel for simultaneous signaling in the reverse direction, with rates up to 75 bits per second. The equipment has been based, in the main, on two recommendations of the International Telegraph and Telephone Consultative Committee, namely *V.23*, which applies to the line-side characteristics, and *V.24*, which applies to the local-side characteristics. Recommendation *V.23* prescribes that frequency modulation shall be used. The rest of the main line-side data is given in Table 1.

Recommendation *V.24* specifies the signals that pass via the so-called interface between the data-processing equipment and the modem equipment. This recommendation deals with a large number of interchange circuits grouped according to the different types of signals. Differentiation is made between data signals, supervisory signals, timing signals, and control signals. Table 2 gives the main data common to all signal types.

The International Telegraph and Telephone Consultative Committee has given designations and numbers to the various interchange circuits

* F. Beerbaum, J. Evans, and F. Leyssens, "Standard Equipment Practice for ITT Europe," *Electrical Communication*, volume 39, number 2, pages 199-211; 1964.

Modems Complying with International Standards

that indicate the purposes for which they are used. These numbers together with their designations are given on the block schematic of Figure 1, which shows a fully equipped terminal. The terminal can be partly equipped to include only those units actually required for a particular application.

The data signals, in binary form, go to the modulator via the interchange circuit Transmitted Data (3). These signals frequency modulate a 9.6-kilohertz carrier. The resultant voice-frequency data signals are then brought down to line frequencies by mixing them with another frequency generated by the translation oscilla-

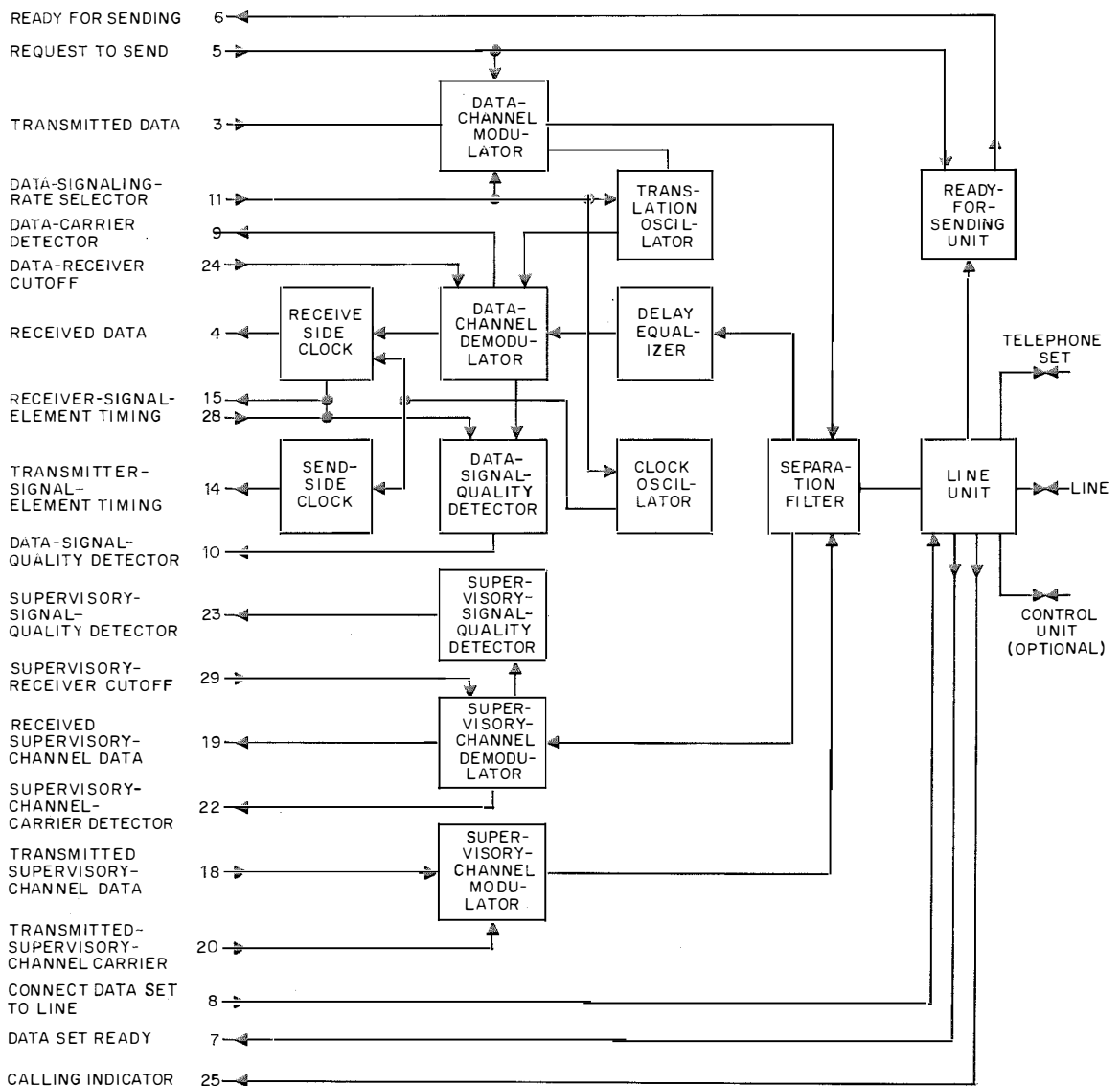

Figure 1—Block diagram of modem equipment type *GH-2002* arranged for synchronous transmission. The numbers refer to interchange circuits as recommended by the International Telegraph and Telephone Consultative Committee.

TABLE 1
GH-2002 FREQUENCY AND MODULATION DATA

	Modulation Rate in Bauds*	Channel Midfrequency in Hertz	Frequency Shift in Hertz
Data channel, switchable between two speeds	600 or 1200	1500 or 1700	400 (± 200) or 800 (± 400)
Supervisory channel	75	420	60 (± 30)

* With binary modulation, the line-side modulation rate expressed in bauds is the same as the local-side signaling rate expressed in bits per second.

tor. Both the frequency shift and the channel midfrequency can be electronically switched between the two alternatives given in Table 1. The switching is performed via the interchange circuit Data-Signaling-Rate Selector (11), which controls the frequencies of both the modulator and the translation oscillator. The voice frequencies are supplied to the line via an amplifier and an attenuator, by means of which the output level can be adjusted. Another interchange circuit, Request to Send (5), is also connected to the modulator. This controls the on and off switching of the outgoing line signals.

At the receive side, the translation oscillator is used to bring the line signals back to a frequency of 9.6 kilohertz. The interchange circuit Data-Signaling-Rate Selector (11) is used to set up the receiver for either of the two channel midfrequencies. After going through a band-pass filter the signals are amplified and then sent via an amplitude limiter to the discriminator. In the discriminator these data signals are reconverted to binary form, after which they are amplified and formed into pulses before leaving the equipment via the interchange circuit Received Data (4).

An amplitude detector, located after the band-pass filter, is used to supervise the level of the received line signals. This information goes out via the interchange circuit Data-Carrier Detector (9). The circuit is connected with the data-signal output circuit in such a way that the output is cut off when the line level is too low. Cutting off the output can also be externally

TABLE 2
INTERFACE BETWEEN OUTPUT OF DATA-PROCESSING EQUIPMENT AND INPUT TO MODEM EQUIPMENT

Signal inputs	Input impedance in ohms	3000 minimum 7000 maximum
	Required signal voltage	3 volts* minimum
Signal outputs	Load impedance in ohms	3000 minimum 2500 maximum
	External capacitive load in picofarads	5 volts* minimum
	Output voltage	25 volts* maximum

* Voltages are given in terms of absolute values.

controlled by a signal via the interchange circuit Data-Receiver Cutoff (24). This latter facility is used in conjunction with the interchange circuit Request to Send (5) to change the direction of transmission with terminals connected for 2-wire operation.

The double-modulation method, which is used for the data channel, has been shown to have decided advantages over the method whereby the line frequencies are directly modulated and demodulated. When frequency modulating with a square-wave signal, a carrier beat interference is obtained having an amplitude that depends on the relative frequency shift; that is, on the relationship between the frequency shift and the

Modems Complying with International Standards

carrier frequency. This interference is practically insignificant for the 9.6-kilohertz carrier frequency chosen in this case. Another advantage of the double-modulation method is that the channel midfrequency can be changed by simply switching the frequency of the translation oscillator. The curve of Figure 2 shows the signal-to-noise ratio, as a function of the signaling speed, at an element error rate of 10^{-5} and a noise bandwidth of 3000 hertz, for a data channel constructed in accordance with the principles described above. The test circuit of Figure 3 was used to carry out the measurements.

The main characteristics of the supervisory channel are given in Table 1. The frequency shift is small in this case, so that the modulation

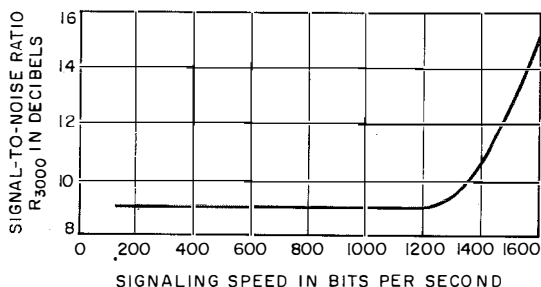

Figure 2—Signal-to-noise ratio as a function of signaling speed at an element error rate of 10^{-5} and a noise bandwidth of 3000 hertz for *GH-2002*.

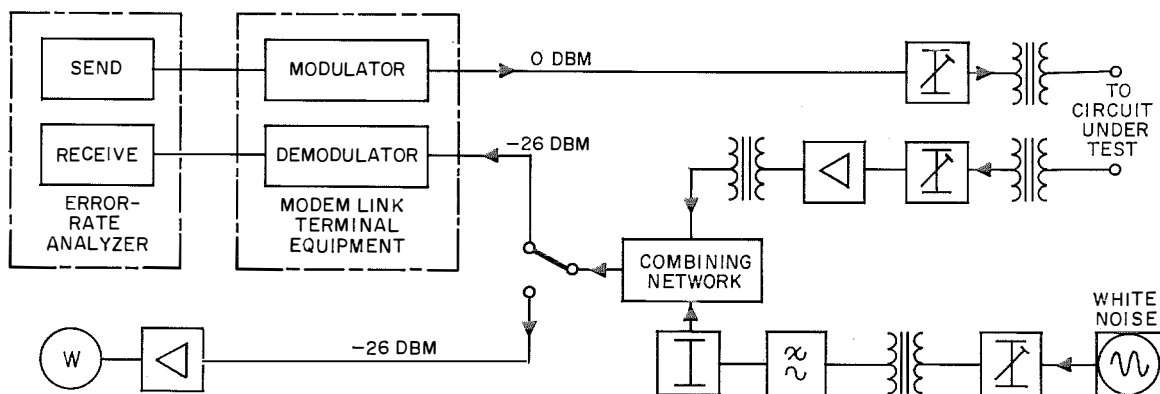

Figure 3—Data-transmission measuring setup with injection of white noise. The wattmeter is a thermocouple instrument for measuring 1 milliwatt.

and demodulation can be carried out in one stage without any significant carrier beat interference being obtained. In other respects the supervisory channel is built up in the same way as the data channel and is equipped with corresponding control circuits. The facilities provided by the supervisory channel (see Figure 1) are made clear by the description of the corresponding circuits in the data channel.

The data channel and the supervisory channel are separated by a separation filter that is available in two versions, one for 2-wire and the other for 4-wire circuits.

The interchange circuit Ready for Sending (6) provides a delayed output signal informing the data source that the circuit is ready to send data a certain time after the carrier is connected to the line. This facility is particularly useful when working over 2-wire circuits and the direction of transmission must be reversed. For several reasons it is not possible to reverse the direction of transmission instantaneously. Line discrepancies give rise to echoes that must be given time to decay. The delay facility guarantees that, after each reversal of the transmission direction has occurred, the data channel is ready for sending before transmission begins. The time delay can be set to 200 ± 20 or 400 ± 40 milliseconds.

Echo suppressors are often fitted on very-long lines such as international circuits, which makes impossible both-way or rapidly reversible 1-way transmission. To overcome this difficulty, the International Telegraph and Telephone Consultative Committee has recommended that, for the transmission of data, the echo suppressors be disabled by sending a special tone (2100 hertz) over the circuit. This means that all echo suppressors will have to be modified to include a disabling circuit that responds to the 2100-hertz tone. The tone is sent from the system modulator during the delay time, that is, before the Ready-for-Sending signal is received.

2.1 DELAY EQUALIZER

Circuits within the telephone network have, in general, a group delay time that varies considerably with frequency. This is not particularly important for speech as the ear is relatively insensitive to group delay distortion. However, the discriminator used in the receive circuit of the modem equipment is very sensitive to this form of distortion.

The demodulated data signals will have a time distortion that depends on the group delay distortion of the transmission channel. In the main the telephone network contains two types of circuits having different group delay characteristics: loaded-cable circuits and carrier-frequency circuits. Large-scale tests, using the modem equipment in conjunction with different types of circuits, have shown which conditions give acceptable transmission. The *GH-2002* has been equipped with a delay equalizer to limit the number of times the signaling rate must be changed from 1200 to 600 bits per second. The equalizer, which is included in the receive side of the modem, can be switched in or out of the circuit as required and is remotely controlled by an external switch.

2.2 SYNCHRONIZING EQUIPMENT

A synchronizing equipment composed of a clock oscillator, a send-side clock, and a receive-side

clock can be fitted in the *GH-2002* types of modem. The clock oscillator is crystal controlled and generates a control frequency for both the send-side clock and the receive-side clock. This clock oscillator can be switched to one of two frequencies, one for a data signaling rate of 600 and the other for 1200 bits per second. The changeover is controlled by a signal at the interchange circuit Data-Signaling-Rate Selector (11).

The send-side clock contains a frequency divider that provides timing signals via the interchange circuit Transmitter-Signal-Element Timing (14). These timing signals can be used in the data source to determine the transmission rate of the data signals. At the receive side the data signals can be made to pass via the receive-side clock, which contains a frequency divider controlled by the polarity reversals of the data signals. Timing signals, which are in synchronism with the data signals, are thus obtained at the interchange circuit Receiver-Signal-Element Timing (15). These signals give the data receiver an indication at the beginning and at the middle of each data signal element, and they are also used within the modem equipment for regeneration of the data signals. Hence the data signals do not have any significant time distortion when they leave the receive-side clock.

2.3 SIGNAL-QUALITY DETECTOR

The *GH-2002* includes so-called signal-quality detectors, which are devices used to supervise the quality of the received signals before they are changed from analog to digital form. Supervision of the data channel takes place in two stages, one by supervision of the received voice-frequency signals and the other by supervision of the discriminator output signals. By setting certain limits for the amplitude of these signals, it is possible to detect a disturbance of sufficient magnitude to cause a binary error in the data signals at the receive-side output.

For this method of supervision to be effective, it is important that the mean level of the line

Modems Complying with International Standards

signals be kept constant. Therefore the signals pass through an automatic-gain-control amplifier that provides a constant output level over a wide range of input levels. The signals are removed after the band-pass filter and go to an amplitude detector. The output signals consist of a direct voltage with a superimposed alternating voltage that corresponds to the line signal envelope. This envelope is relatively small if the quality of the transmission line is good, but increases as a result of delay distortion, for example. Pulse disturbances give rise to simultaneous momentary increases of the envelope. The envelope voltage normally lies between two threshold levels, and if either of these levels is exceeded an alarm is sent via the interchange circuit Data-Signal-Quality Detector (10). This same interchange circuit is also used for alarm signals from the discriminator output, which is supervised by two predetermined threshold levels in much the same way as the envelope voltage.

A signal-quality detector is also included in the supervisory channel. In this case only the discriminator output signal is supervised, and alarms are taken out over the interchange circuit Supervisory-Signal-Quality Detector (23).

The threshold levels used here have been determined after comprehensive tests on loaded-cable and carrier-frequency circuits, together with the error detection and correction equipment in the *GH-201* type of data-communication system.

2.4 LINE UNITS

The modem equipment can be provided with different line units depending on its application. Two different types of line unit are available at present.

The line unit used in the *GH-2002A* equipment (see Figure 1) is intended for connection to the public telephone network or to 2-wire private lines. It contains a relay for connecting the line to the modem equipment or the tele-

phone set. This relay is controlled either via the interchange circuit Connect Data Set to Line (8), or by means of a connection in an external control unit. The relay condition is indicated both by a lamp in the control unit and by a voltage at the interchange circuit Data Set Ready (7).

The line unit also includes circuits that automatically connect the modem equipment to the line when a call is received. The exchange of data then begins automatically, on the assumption that the connected data terminal is ready. The connection can be broken either by the calling station interrupting the outgoing carrier, or by the called station indicating that the connection is no longer required. The interchange circuits Request to Send (5) and Connect Data Set to Line (8), respectively, are used to initiate the disconnection. A so-called announcement machine can be connected to the modem equipment. In the event that a telephone subscriber is connected as a result of having dialed incorrectly, the machine automatically requests the subscriber to disconnect. If for any reason the data connection is not completed within a predetermined time after a call has been made, a time supervision circuit in the automatic answering unit will automatically disconnect the connection.

The line unit used in the *GH-2002B* equipment is mainly intended for 2-wire or 4-wire private lines, but can also be used for connection to the public telephone network. The unit is equipped with two line transformers. If it is required to use the line for both data transmission and speech, the necessary switching can be controlled from, for example, an external control unit.

Both types of line units are equipped with screw-type terminals for connecting the telephone line and the control unit when used. A telephone set and an announcement machine can also be connected to the line unit in the *GH-2002A* type of equipment.

3. Modem Equipment, GH-1101

The *GH-1101* type of modem contains equipment for both-way data transmission, full duplex, over 2-wire circuits, with data signaling rates up to 200 bits per second. The equipment is designed in accordance with recommendation *V.21* of the International Telegraph and Telephone Consultative Committee. A block schematic of the equipment is shown in Figure 4.

The frequency band available for transmission is divided into two channels with the help of a separation filter. The modulator and the demodulator can be connected to work over either of the two channels, the connection being con-

trolled by external signals. Table 3 shows the channel frequencies and their dispositions.

Frequency modulation is used and the frequency shift is 200 hertz. As the relative frequency shift is small, it is possible to carry out the modulation at line frequencies without introducing unacceptable distortion. The data signals go to the modulator via the interchange circuit Transmitted Data (3), and the channel midfrequency is selected by means of a signal at the interchange circuit Select Transmit Frequency (26). The latter signal also connects the carrier-frequency signals to the correct side of the separation filter. Before this, the signals pass through an amplifier that has an attenuator for adjusting the send level. The amplifier contains a blocking circuit that is controlled via the interchange circuit Request to Send (5). The blocking circuit helps to connect or disconnect the line signals.

The received carrier-frequency signals are supplied via the separation filter to a translating modulator, which converts them to a higher frequency band. This frequency depends on the frequency of the translation oscillator and is

Terminal	Modulator Frequency in Hertz	Demodulator Frequency in Hertz
Calling	1080 ± 100	1750 ± 100
Called	1750 ± 100	1080 ± 100

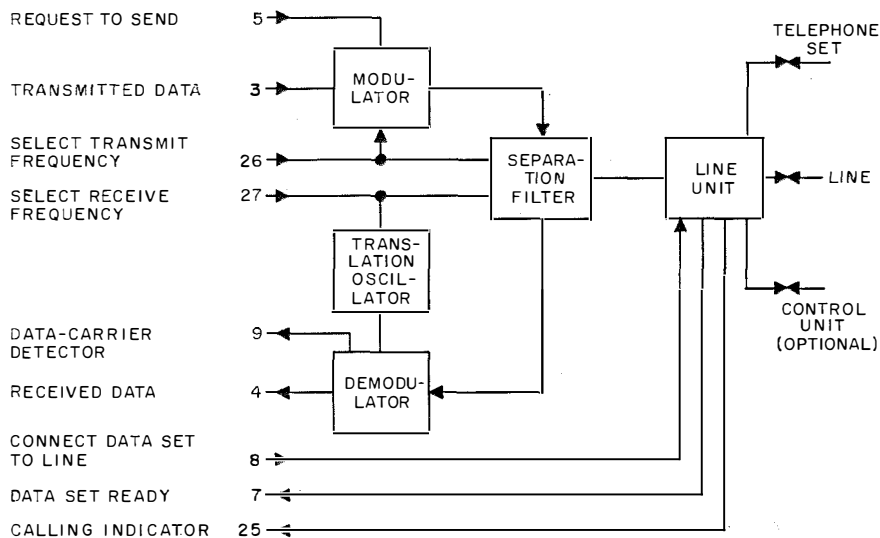

Figure 4—Block diagram of modem equipment type *GH-1101A*. The numbers refer to interchange circuits as recommended by the International Telegraph and Telephone Consultative Committee.

Modems Complying with International Standards

controlled by a signal at the interchange circuit Select Receive Frequency (27), so that the mixer frequency is the same regardless of which of the two channel frequencies is received. In the following demodulator, the carrier-frequency signals first go to a band-pass filter, which selects the required frequency band from the translation-modulator output. The signals then pass through an amplifier and an amplitude limiter to the discriminator, where the data signals are changed back to digital form. After pulse shaping, the signals leave the equipment via the interchange circuit Received Data (4). The demodulator amplifier is equipped with an amplitude detector that supervises the amplitude of the carrier-frequency signals. Information from this detector is taken out over the interchange circuit Data-Carrier Detector (9). The detector is connected to the data signal output, so that the latter is blocked and prevents the transmission of data if the input level falls below the predetermined minimum operating level for the equipment. The blocking of the output signal can also be controlled by means of a signal at the interchange circuit Data-Receiver Cutoff (24).

4. Mechanical Construction

The printed-wiring boards used in the equipment are mounted in subracks consisting of 2 steel-plate side members fastened together by 4

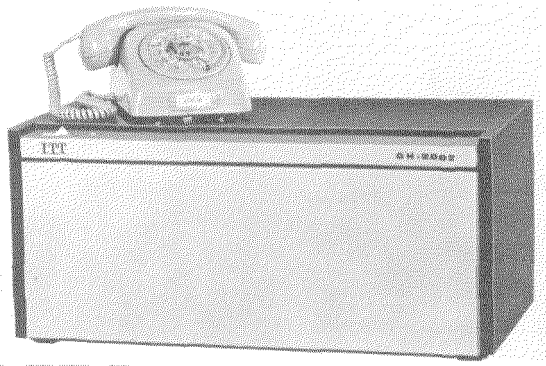

Figure 5—GH-2002 equipment in desk-top cabinet.

steel crossmembers. The crossmembers have threaded holes for mounting the board contact sockets and larger units such as the power unit and the line unit. The plug-and-socket-type connectors for the external connections are mounted so that they are easily accessible. The connectors used for the standardized interchange circuits are multitag connectors of an internationally approved type. The transmission line is connected to the line unit by screw-type terminals. The line unit is also equipped with terminals for connecting the telephone set, the announcement machine, and the control unit. Protected screw terminals are provided for connecting the mains supply.

The equipment can be mounted in a rack 19 inches (483 millimeters) wide or in a special desk-top cabinet. The cabinet version of the GH-2002 is shown in Figure 5. The GH-1101 equipment is mounted in a cabinet of the same size. To simplify the installation of these desk-top cabinets, the equipment is reversed so that all connections are made at the rear of the cabinet. The cabinet case is also equipped with a mains circuit breaker, a mains indication lamp, and a cord for connection to the mains supply.

All the voltages required by the equipment are obtained from a standard power supply. This unit is designed for connection to single-phase mains supplies and can be switched to operate from either 100–125 or 200–250 volts. The mains transformer satisfies the applicable safety regulations.

L. O. Kjell Edvardsson was born in Hällesjöe, Sweden, on 24 December 1931. He studied telecommunications at the Technical College of Örebro, and received a BE degree in electrical engineering in 1952.

After four years with the L. M. Ericsson Company he joined Standard Radio & Telefon in 1957, where he is now a project engineer working on telegraph and data modem equipments.

Modem Equipment for Parallel Data Transmission

B. LINDSTRÖM

Standard Radio & Telefon AB; Barkarby, Sweden

1. Introduction

Data communication via the telephone network often demands only a modest transmission speed because, in many cases, the amount of data to be transmitted is relatively small. Naturally a lower transmission speed will result in higher line costs per bit but this is offset by the fact that, with lower speeds, it is possible to reduce the cost of the terminal equipment. For international traffic the line costs must be considered, but in most cases the telephone charges are not the decisive factor. Therefore, if the amount of data to be transmitted is not excessive, a transmitting method should be chosen that gives the lowest terminal costs.

The division of the costs between the send and receive terminal equipments is also important. Developments in the data-processing field have resulted in demand for a system in which data are collected at a number of stations that transmit to one main data center. In such cases it is particularly advantageous to reduce the cost of the send terminal equipment, even if this results in an increase in the cost of the receive terminal.

Punched cards and punched tape are suitable media for data recording if only a moderate amount of data is to be collected and transmitted. As an alternative, data can be transmitted directly from a keyboard. In such cases the cost of the send apparatus will be a minimum if it is designed to transmit the bits for each character in parallel form. The bits making up a character are transmitted simultaneously as binary conditions on a number of parallel wires or on a number of different frequencies in the transmission band. The cost of the send terminal modem equipment can be relatively low with this method of data transmission, but the receive terminal modem is somewhat more expensive than the receive modem required for series transmission. However, the increase in cost is compensated for by the fact that the conversion between parallel and series form is eliminated. This is true even

if the number of send and receive terminals is the same.

For a number of years the Bell Telephone System of the United States has been able to supply modem equipment for parallel data. An important result of this is that two different modulation methods have come into use, one for punched tape and the other for punched cards. However, in cases where telecommunications administrations wish to supply modem equipment to their customers, it would be an advantage if they were in a position to supply a universal type of modem equipment that could easily be adapted to different types of input and output media. A Swedish solution to this problem has aroused great interest in many places and is at present being studied within the International Telegraph and Telephone Consultative Committee. The modem equipment described in the following pages is based on this solution. The equipment went into production during the latter half of 1964 and is coded *GH-4002*. A complete data-communication system, based on this type of modem, was also developed and is coded *GH-403*.

2. Fundamental Principles for *GH-4002*

Sixteen frequencies from 930 to 2070 hertz are used for the transmission of data. These frequencies are divided into 4 groups of 4 frequencies each. To transmit a particular character it is necessary to send only 1 frequency from each frequency group. The frequency coding can therefore be considered as 4 times 1-out-of-4 or, in other words, 4-out-of-16. If only 2 or 3 of the frequency groups are used, the frequency coding will be 2-out-of-8 or 3-out-of-12, respectively.

The 4 groups of frequencies are given in Table 1. It will be seen that the frequency separation within a group is 60 hertz. The frequency separation is 180 hertz between the 2 middle groups of frequencies, and 120 hertz between the remaining groups. The highest frequency within

Modem Equipment for Parallel Data Transmission

each group has been given the binary number 00, and the remainder in frequency order 01, 10, and 11. The frequency groups have the letters *A*, *B*, *C*, and *D*, with *A* containing the lowest frequencies. For the rest condition, the highest frequency in each group (00) is transmitted. The changeover to the other 3 frequencies takes place via a special modulating circuit having 3 data signal inputs per group.

Frequency space is available for a special timing channel between groups *B* and *C*. This channel employs frequency-shift modulation with a midband frequency of 1500 hertz and a frequency shift of ± 30 hertz. The channel is used for the transmission of timing signals in such a manner that a frequency shift occurs each time a new character is received at the data signal inputs.

Signal Conditions	Signal Frequency in Hertz			
	Group A	Group B	Group C	Group D
00	1110	1410	1770	2070
01	1050	1350	1710	2010
10	990	1290	1650	1950
11	930	1230	1590	1890

Group A	Group B	Group C	Application
00	00	00	Rest condition
01, 10, 11	00	00	Numerals 1-3
00, 01, 10, 11	01	00	Numerals 4-7
00, 01	10	00	Numerals 8-9
00	00	11	Numeral 0
01, 10, 11	00	01, 10, 11	} 27 letters
00, 01, 10, 11	01	01, 10, 11	
00, 01	10	01, 10, 11	
11	10	00	} 5 functional characters
00, 01, 10, 11	11	00	

Supervisory signals can be transmitted from the receive to the send terminal over a frequency-modulated or amplitude-modulated supervisory channel. The latter alternative employs a carrier frequency of 390 hertz and the former alternative has a midband frequency of 420 hertz with a frequency shift of ± 30 hertz. The former is also in accordance with the recommendation of the International Telegraph and Telephone Consultative Committee for a standard supervisory channel for series data modems and can be used at any transmission speed up to 75 bits per second.

2.1 MODULATOR

The signaling condition is obtained by directly connecting the data signal input in question, or the timing signal input, to the return wire that is common to all the inputs. The construction of the modulating circuit is such that the electrical data for the connecting cables can be chosen somewhat arbitrarily, without risk that the signaling frequencies will be affected. Data contacts equipped with resistance-capacitance type of contact protection can therefore be tolerated.

The modem possesses the important property that simultaneous signaling at the inputs of the frequencies 01 and 10 within a group, results in a changeover to frequency 11. This means that signaling can take place in two different ways. In the first method all three inputs within one group are used, with the restriction that signaling can take place on only one input at a time. In the second method only the 01 and 10 inputs in the group are used, and with this method simultaneous signaling on both inputs is also acceptable. Any one method of signaling can be used for the individual groups, whereby different coding possibilities are obtained.

Another important property of the modulator is that it is direct-current controlled. This means that a direct current flows across the contacts used for signaling, considerably reducing the demands made on these contacts. Hence the most-serious source of faults in existing sys-

tems has been eliminated. Direct-current control also makes possible a simple code conversion by means of an external diode matrix, whereby the required transmission code can be obtained even if the data source presents each character by closing a single contact. This is the case, for example, with most types of punched-card readers.

2.2 DEMODULATOR

At the receive terminal each frequency group is treated as two frequency-shift channels. Each channel has a frequency shift of ± 30 hertz and there is a difference of 120 hertz between the midband frequencies. As only 1 of the frequencies in a group is present at any time, one of the channels within the group is always in the no-tone condition. Consequently frequency detection can take place by means of a combination of frequency-modulation and amplitude-modulation detection.

As the timing channel is a normal frequency-modulated channel, a conventional frequency-modulation discriminator is used for demodulation in this case. After a certain delay, sampling pulses are generated each time the timing signal passes through zero, that is, changes polarity. These sampling pulses can be used to regenerate the data signals. An alternative method of data signal regeneration can be employed, in which case the timing channel is not required.

If a timing channel is used to regenerate the data signals, the optimum synchronization is obtained between the send and receive circuits, without it becoming necessary to maintain a constant signaling rate over the channel. With this method of regeneration, the maximum data transfer rate is 75 characters per second. Then each character takes up the full length, which means that the signals cannot be allowed to return to the rest condition between characters.

A return to the rest condition between characters, which will take place if the frequency of each group becomes 00, can be used to generate

sampling pulses for data regeneration. A timing circuit is actuated each time a shift from the rest condition is detected, and after a predetermined delay this circuit gives the required sampling pulse. Another timing circuit transmits in turn a reset pulse that fixes the length of the regenerated character. This method of regeneration is suitable for data transfer rates of up to 20 characters per second; with a ratio of 1:1 between character and rest condition, it gives a minimum character length of 25 milliseconds. This character length has been chosen for the receive-side regenerated character, even if the character exceeded 25 milliseconds when supplied to the send circuit.

2.3 DECODING

After the transmitted signals have been detected and regenerated, the data code is rebuilt in a logic circuit. The resultant signals then go to the data outputs via output relays. For the contacts of these relays to deliver data characters in the same form as the characters going to the modulator circuits, the method of decoding must correspond to the signaling method used at the transmit terminal. When the signaling method is such that frequency 11 represents simultaneous signaling at the inputs of 01 and 10, the decoding must be carried out in such a way that an indication of 01 is obtained for both the frequencies 01 and 11. In the same way an indication of 10 must be obtained for both the frequencies 10 and 11. If, on the other hand, the respective frequencies represent only signaling at the corresponding inputs, the decoding is carried out so that individual indications are obtained for all frequencies in the group.

As a complement to the data signals, the timing signal is indicated by a contact closure of short duration. This closure occurs at the commencement of each delivered character. In addition, a contact closure is obtained at a special output, indicating that all the groups are in the rest frequency condition.

Modem Equipment for Parallel Data Transmission

2.4 USE OF SIGNALING SYSTEM

As already stated, the principles permit signaling to take place in two different ways. It is also possible to use a combination of these two signaling methods. Some examples follow that describe how the groups can be used to meet the requirements of certain typical applications.

Figure 1 shows the transmission of data from, for example, punched tape or edge-punched cards having a maximum capacity of 8 bits per character. Manual keyboards with suitable internal coding can also be connected.

Figure 2 shows how the modem equipment can be used to transmit data from conventional punched cards. Thanks to the diode matrix,

only single contact connections are required from the data source, and thus it is possible to use the equipment with all normal types of punched-card readers that read character by character. The 12 data signal inputs make it possible to transmit alphanumeric information, and it is recommended that the frequency coding of Table 2 be used in such cases.

Figure 3 shows a simplified arrangement with only 2 frequency groups. This arrangement can be of interest for numeric applications where the cost of the equipment is especially important. This is the case if the amount of data from any send terminal is relatively small, but on the other hand the number of outstations is very large. The coding differs from that of

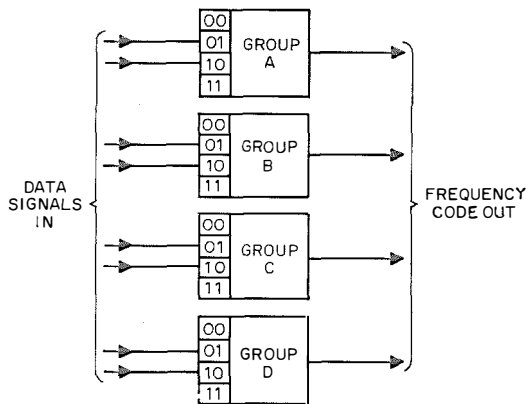

Figure 1—Diagram of 4 frequency groups for 8-unit binary coded data.

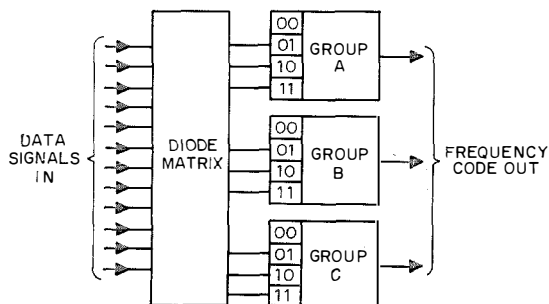

Figure 2—Diagram showing 3 frequency groups for a 12-line punched-card reader with single-pole contacts.

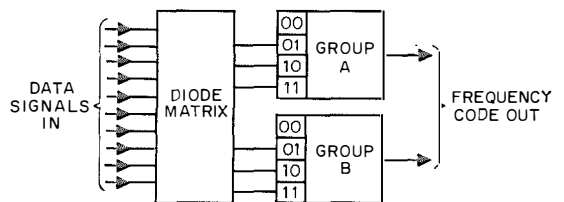

Figure 3—Diagram showing 2 frequency groups and 10 data input leads for numeric information from punched cards or a manual keyboard.

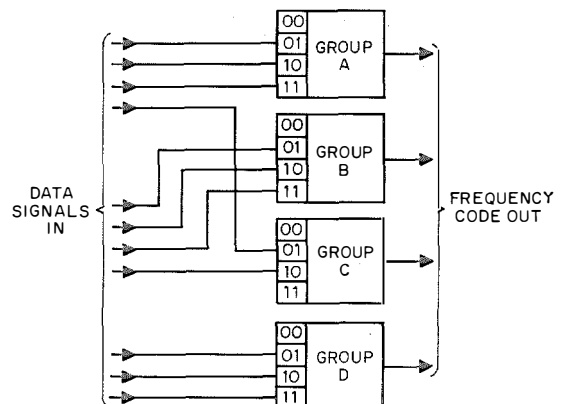

Figure 4—Diagram of 4 frequency groups for punched-card information in alphanumeric code.

Figure 2 with respect to the numeral 0. The reason for this difference is that in the alphanumeric code the 0 input is also used as a letter shift.

Figure 4 shows an arrangement for the so-called 3-out-of-14 code. This presupposes that there are three sets of interchange circuits, two comprising 4 circuits each and one comprising 3 circuits. Each of these interchange circuits will correspond to a characteristic modulation condition, apart from the condition in which no interchange circuit is connected within the respective set. One set of interchange circuits consists of the inputs 01, 10, and 11 in group *A* together with 01 in group *C*; another set consists of the 01, 10, and 11 inputs in group *B* together with input 10 in group *C*. The set having 3 interchange circuits consists of the inputs 01, 10, and 11 in group *D*.

3. Modem *GH-4002*

The *GH-4002* modem is suitable for use in all the examples discussed. All requirements can be satisfied without any modification of the send-side modem equipment, on the assumption that the diode matrices that may be required are not considered part of the modem equipment. Certain changes are necessary in the receive equipment, so that the correct decoding is obtained for any particular application. However, as the modem equipment for alphanumeric punched-card data can also be used for applications employing only numeric information, only two alternatives of the receive equipment are required. A modem equipment has been constructed, having the code *GH-4002*, that is based on these requirements. The send terminal equipment has the code *GH-4002A*. The receive terminal equipment, which has the code *GH-4002B*, is made suitable for the two decoding systems by changing a few of the circuit boards.

3.1 SEND EQUIPMENT *GH-4002A*

A block schematic of the send equipment is shown in Figure 5. The equipment includes the

modulators for the 4 frequency groups, the timing channel modulator, and the receive amplifier for the supervisory channel. The latter is constructed in accordance with the amplitude-modulation signaling alternative and is intended primarily for acoustic supervision of the transmission. All these circuits are connected to the line unit. This unit includes the phone/data switch, which is used to connect the telephone line to the modem equipment in one position and to the telephone set in the other position. Two push-button test switches, by means of which all the frequency shifts can be made, are also included in the equipment.

The interface connections depend on the application for which the equipment is to be used. The data signals are supplied to the data signal inputs by closing the respective inputs to a common return at pin 11. This return wire is connected to signal earth at pin 24 via a control input at pin 25. The timing signal input is also operated by means of a contact closure. An audible device, such as a telephone receiver capsule, can be used for the reception of the supervisory signals. When the phone/data switch is in the data position, a connection is made between pins 13 and 24 and an indicator lights. This lamp is built into the phone/data switch.

When punched-card data are transmitted in 3-out-of-14 code, the data signal inputs are arranged in accordance with Figure 4. The first and second sets of interchange circuits are made up of the inputs at pins 2, 3, 12, 7, and 4, 5, 14, 8, respectively. The third set, which includes three interchange circuits, is made up of the inputs at pins 9, 10, and 16.

It is possible to transmit binary coded data with up to 8 bits of information (for example from a punched-tape reader) by using the 8 inputs at pins 2, 3, 4, 5, 7, 8, 9, and 10 (compare with Figure 1). The input at pin 6 can be used at the same time to supply the timing signals.

The signal level of each tone supplied to the line is -12 decibels referred to 1 milliwatt,

Modem Equipment for Parallel Data Transmission

which gives a total average power to line of -5 decibels referred to 1 milliwatt. The lowest receive level for the supervisory signals is -40 decibels referred to 1 milliwatt. The equipment can be operated from low-voltage direct or alternating current. A special transformer, which can be plugged directly into a wall socket, is provided for operation from alternating-current supplies.

Except for the line unit, all the circuits are laid out on printed-wiring boards mounted in a case as shown in Figure 6. All the connections are made at the rear of the case. The telephone line is connected by means of a cord and plug and the telephone apparatus by means of a jack. Hence installation is very simple. A 25-pin connector is used to connect the subscriber's data equipment.

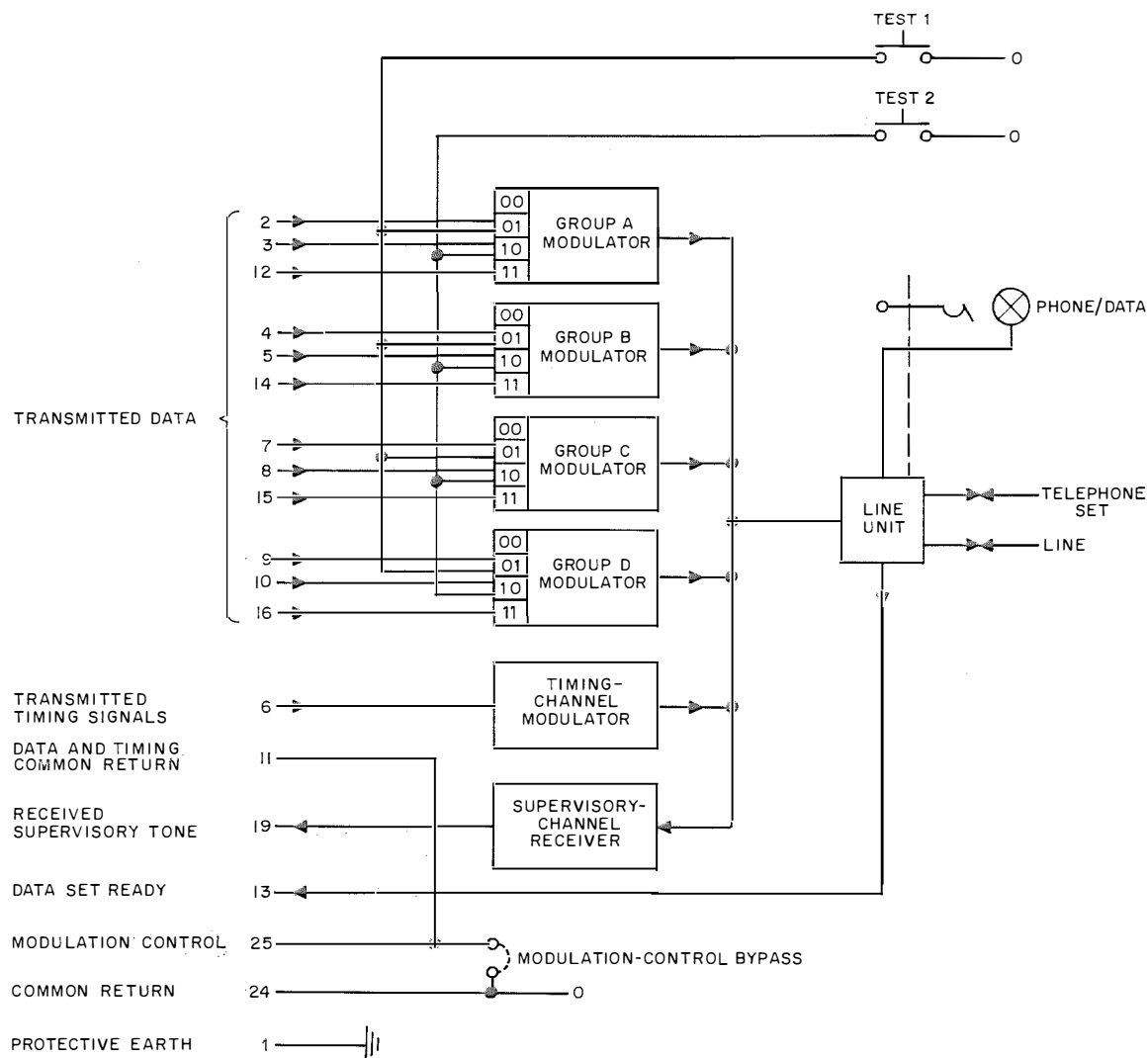

Figure 5—Block schematic of GH-4002A modem. The numbers refer to interface connector pins.

3.2 RECEIVE EQUIPMENT GH-4002B

3.2.1 Standard Version with Direct Output from a Decoder for 8-Unit Binary Code

A block schematic of the receive equipment is shown in Figure 7. It will be seen that, insofar as the telephone line and telephone apparatus connections are concerned, the line-unit arrangements are different from those at the transmit terminal. The line unit contains,

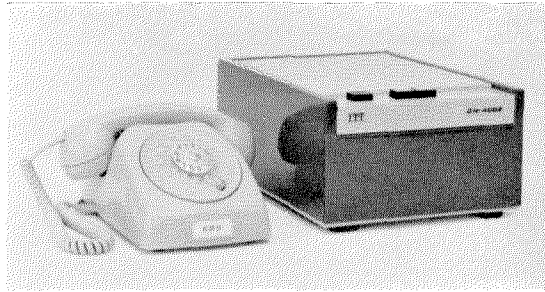

Figure 6—Send equipment GH-4002A.

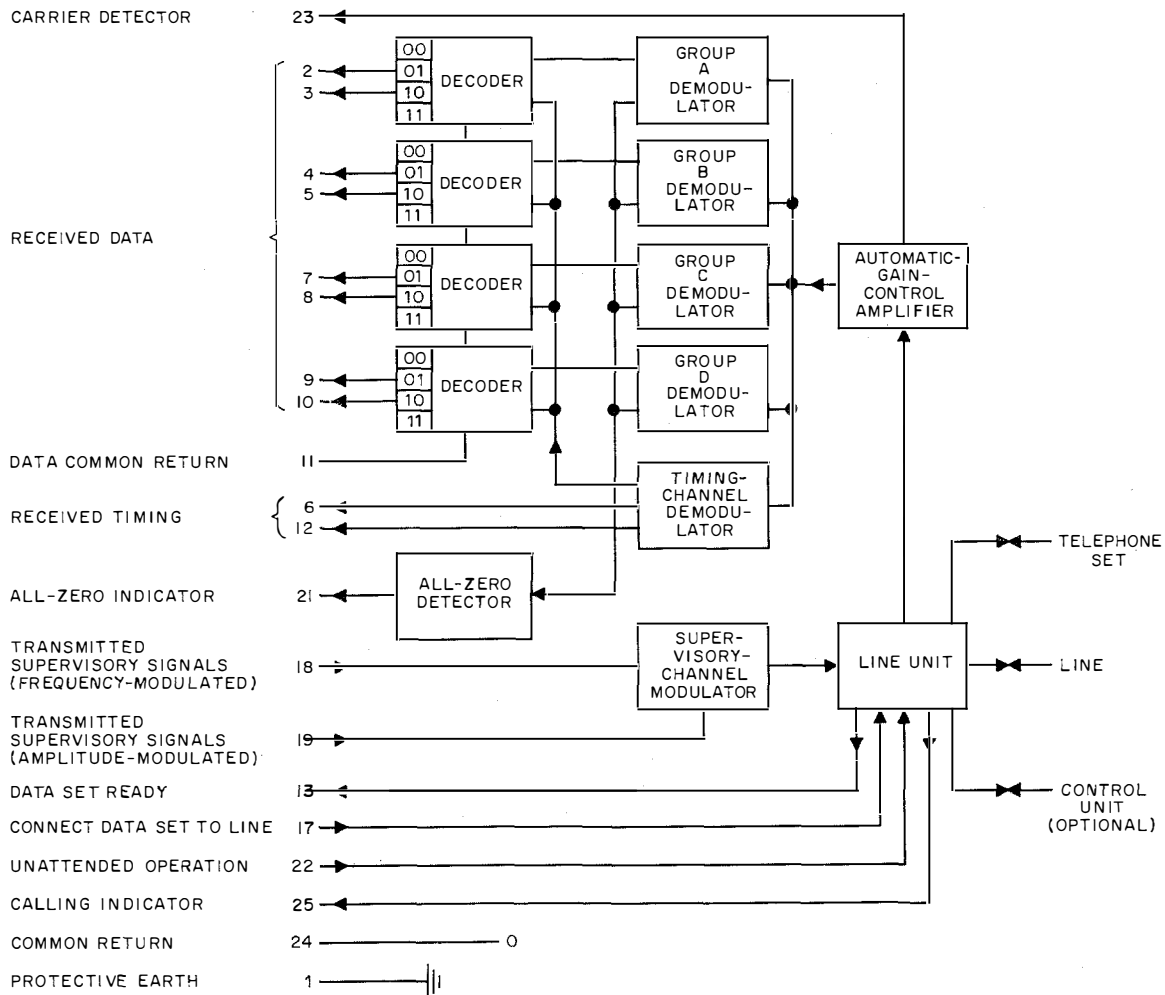

Figure 7—Block schematic of GH-4002B modem for reception of 8-unit binary coded data.

among other components, a switching relay that switches over from telephone to data when energized. In the data position, the telephone line is connected to a separation filter via a line transformer. One side of this filter is connected to the supervisory-channel modulator, and the other to an amplifier with automatic gain control that supplies the demodulator circuits. The respective frequencies for each frequency group are evaluated and then the data signals are decoded. The regeneration of the data signals is controlled by the transmitted timing signals. The decoded characters take up the full length, that is, there is no changeover to the rest position between characters. Transfer rates of up to 75 characters per second are possible if this method of regeneration is used.

All the received data contacts on the output relays are commoned on one side at pin 11, and connections are made between this output and the 8 data signal outputs. Each time a completed character is obtained at the data signal outputs, a connection of short duration is obtained on the timing signal outputs at pins 6 and 12. When pin 21 is connected to pin 24, the rest signal condition is obtained on all groups simultaneously.



Figure 8—Receive equipment *GH-4002B*—desk-top cabinet.

When the carrier is present, the potential at pin 23 is positive with respect to that at pin 24. If a break occurs in the transmission of the carrier, a negative potential is obtained at pin 23. The transmission of a tone over the supervisory channel is initiated when pin 18 is connected to pin 24.

The regulation range of the automatic-gain-control amplifier allows a line attenuation of 40 decibels. The send level in the supervisory channel can be adjusted, in steps of 2 decibels, within the range from -6 to 0 decibels referred to 1 milliwatt.

If manual operation is used at the main station, a call is answered in the usual way with the telephone set connected to the line, after which the switchover to data transmission is made by connecting pin 17 to pin 24. The fact that the switchover to data has been made is indicated by a connection between pins 13 and 24. At unattended main stations a call is indicated by a positive potential on pin 25. The call is answered automatically if pin 22 is connected to pin 24. Switchover to data takes place, and negative potential is again obtained on pin 25, if pin 17 is connected to pin 24. This condition can be eliminated by making internal connections. It is possible, by means of recorded speech for example, to give information to the calling station before the switchover to data occurs.

The equipment consists of circuit boards mounted in 3 subracks. The subracks are housed in a desk-top cabinet shown in Figure 8. The connections to the telephone line and the telephone set are made at the back of the cabinet. A 25-pin connector is also provided for connecting the customer's data equipment. A mains supply switch and an associated indicating lamp are mounted at the front of the cabinet.

3.2.2 *Special Version for the 3-out-of-14 Data Code*

As can be seen from the block schematic of Figure 9, there is no timing channel in this

equipment. The modulation is based on the assumption that there is return-to-zero condition (00 frequency in each frequency group) between adjacent characters. Pulses are produced by the return-to-zero condition and are used to regenerate the data signals. It is possible to use transfer rates of up to 20 characters per second when this method of regeneration is employed.

The data signal outputs at pins 2 through 18 form three groups as shown in Figure 9. One pole of the relay contacts within each group is connected to the common return. The customer receives data signals in the form of contact

connections lasting 25 milliseconds between these common outputs (pins 7, 13, and 18) and one of the other outputs in the respective group. The rest condition connects the respective common wires and pins 2, 8, and 17. Connection between the common wires and the remaining outputs gives the character code. Detection of the characters can occur, however, only as long as pin 21 is connected to pin 24 (signal earth).

The equipment is housed in the same type of desk-top cabinet as that used for the standard version. It is merely necessary to exchange one or a few of the circuit boards to change from one version to the other.

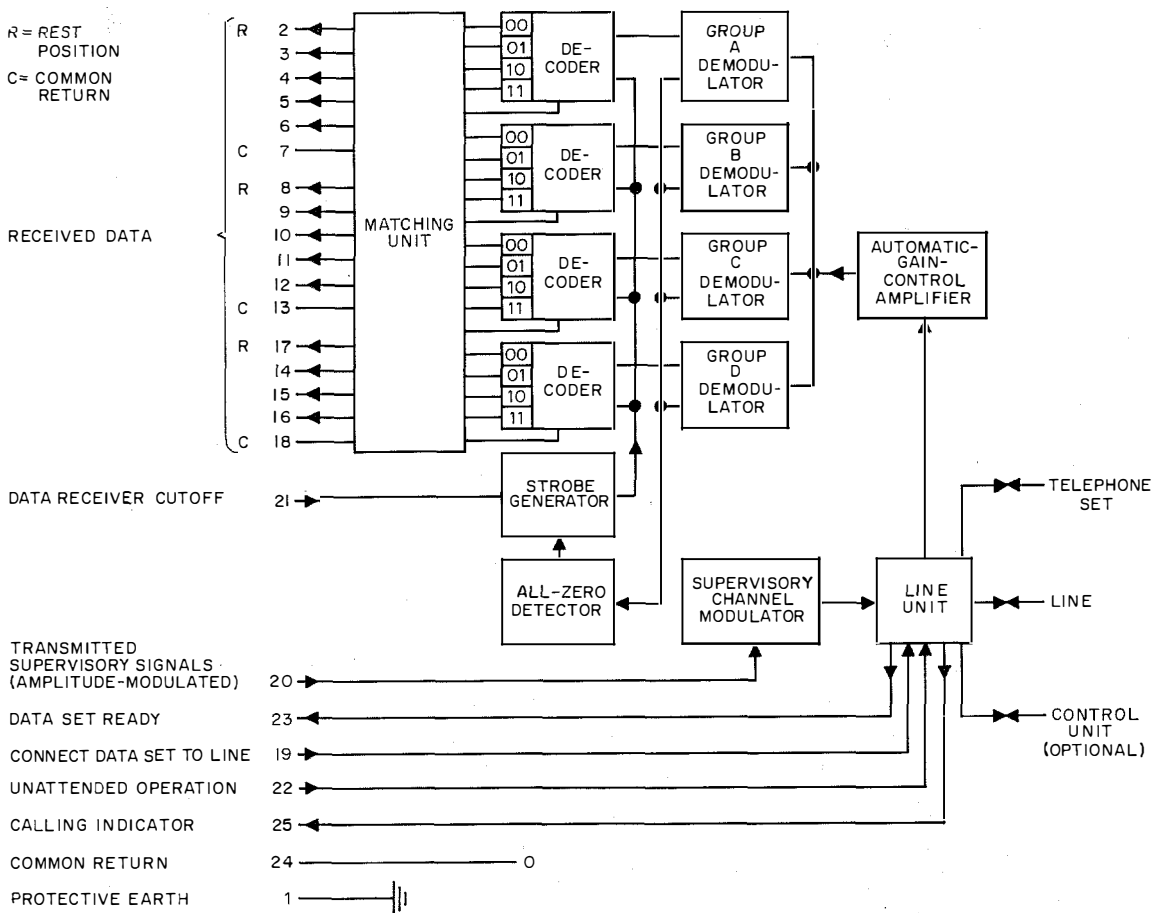

Figure 9—Block schematic of GH-4002B modem for reception of 3-out-of-14 data code.

Modem Equipment for Parallel Data Transmission

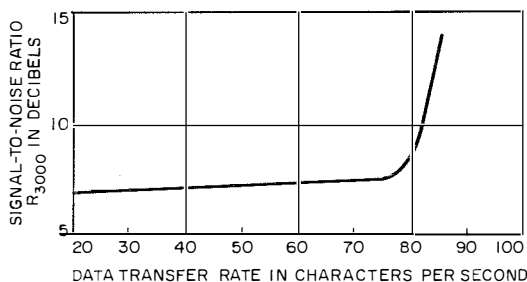

Figure 10—Signal-to-noise ratio as a function of data transfer rate at a character error rate of 10^{-3} and a noise bandwidth of 3000 hertz for *GH-4002* with timing channel.

4. Test Results

Tests were carried out on the *GH-4002* modem equipment using a special measuring set called Epa. This name is derived from its full title, Error-Rate Analyzer for Parallel Data. Epa was developed concurrently with the development of the *GH-4002*.

The tests were carried out with injected disturbances in the form of white noise of limited bandwidth, using different combinations of the system parameters. The curves of Figures 10 and 11 show the relation between the signal-to-noise ratio in decibels and the data transfer rate in characters per second with a character error rate of 1 faulty character per 1000 transmitted.

Figure 10 shows the results of measurements carried out on the *GH-4002B* equipped with a timing channel (see Figure 7). The curve shows that the effect of disturbances is rela-

Bruce Lindström was born on 25 April 1927 in Chicago, Illinois. In 1932 his family moved to Sweden. He received a BE degree in mechanical engineering from the Technical College of Norrköping in 1949, and an MS degree in electrical engineering from the Chalmers Institute of Technology in Gothenburg in 1956. From 1955 to 1960 Mr. Lindström worked for

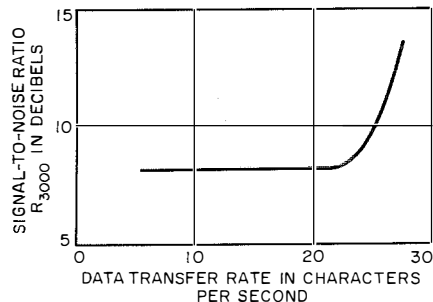

Figure 11—Signal-to-noise ratio as a function of data transfer rate at a character error rate of 10^{-3} and a noise bandwidth of 3000 hertz for *GH-4002* without timing channel.

tively constant up to 75 characters per second. The results of similar measurements carried out on the *GH-4002* without timing channel (see Figure 9) are shown by the curve in Figure 11.

As a complement to the above measurements, the equipment was tested when connected to the telephone network. Standard telephone sets were used for making the test loop connections. Solna, in the Stockholm area, was used as the test center and from this center two different telephone sets were used to ring the repeater station in Gothenburg. In Gothenburg the two lines were connected together. Measurements were carried out over a number of routes and with different transfer rates. The error rates obtained were of the same order of magnitude as those obtained when making similar measurements on equipment for series data. Typical results indicate that error-free periods vary between 10 000 and 1 000 000 characters.

the L. M. Ericsson Company, where he was engaged in the development of electronic switching equipments.

In 1960 he joined the Transmission Division of Standard Radio & Telefon, where he is a project engineer for data-transmission systems.

Mr. Lindström is a member of the Swedish Association of Engineers and Architects.

Special Measuring Equipments for Data Transmission

B. LINDSTRÖM

Standard Radio & Telefon AB; Barkarby, Sweden

1. Introduction

The introduction of data-transmission systems produced a simultaneous demand for measuring methods that could determine both the quality of the terminal equipment and the effect of the transmission medium on the data-transmission reliability. The latter factor was the first to be considered within the International Telegraph and Telephone Consultative Committee, and it was recommended that measurements be carried out in the member countries to determine whether the telephone network was a suitable medium for the transmission of data.

Standard Radio & Telefon initiated a long-term development of diverse measuring equipments at the same time that the first data-transmission modem equipments were being designed. The aim was to produce a measuring set that could satisfy both the requirements described above. At that time only the series form of data transmission was discussed.

2. Felix

The first error-rate analyzer was given the name Felix and the model code *M1001*. Felix was relatively uncomplicated but nevertheless played a part in the measuring equipment program. Both the send and receive parts of the analyzer were mounted in the same case and were controlled from a common control frequency generator. A multivibrator generated a frequency that was adjustable over the working range. The error-rate analyzer was equipped with delay circuits that could be adjusted manually. They served to compensate for the delay time of the transmission medium. The received characters were controlled on an element-by-element basis. The polarity errors and the number of transmitted data blocks were recorded by counters. Each data block consisted of 256 characters of 8 bits each. The test program consisted of the repetition of a selected 8-bit character or, alternatively, a program could be generated that included all combinations of 8 bits in binary-number sequence.

3. Felinda

Felinda was the next error-rate analyzer to be designed, and only a limited number were manufactured. It was constructed with separate send and receive units having the model codes *M1002* and *M1003*. This analyzer is shown in Figure 1. The generated data block was similar to that used in Felix. However, the send and receive units were intended for use as entirely independent items and were therefore equipped with separate crystal-controlled oscillators. These oscillators provided a choice of 18 different signaling speeds within the range from 50 to 3000 bits per second. The receive unit was designed to be self synchronizing, which considerably simplified the operation of the analyzer.

4. Era

As a result of the experience gained with Felix and Felinda, a more-advanced type of error-rate analyzer was developed known as Era, model code *M1004*. This name is obtained from the initial letters of error-rate analyzer. This analyzer can be used for the measurement of

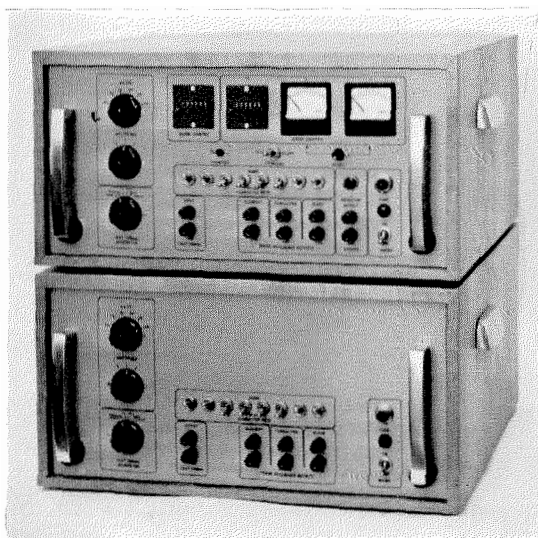

Figure 1—Felinda error-rate analyzer with the receiving set above the sending set.

Measuring Equipments for Data Transmission

polarity errors and for different types of time distortion measurements. Era has been produced in quantity and has been delivered to various European countries and to the United States. Figure 2 shows the analyzer in use.

It will be seen from Figure 3 that the send and receive parts of the analyzer have been constructed as one unit having a common control oscillator and a common power supply. This arrangement has proved to be the most practical because, in the main, measurements are made with the data-transmission circuit looped. However, by using two analyzers, it is possible to carry out end-to-end measurements.

Measurements can be made with a large number of different signaling speeds. The analyzer is provided with 24 crystal-controlled speeds, within the range from 45 to 3000 bits per second, which can be used for carrying out end-to-end measurements. Measurements can also be made at any arbitrary speed within the range from 25 to 3000 bits per second, if an external control oscillator is available that has the necessary stability. The same facilities are available for looped measurements, except that an external oscillator need not be used in this case. Both send and receive circuits are provided with timing signal outputs that indicate the phase condition of the transmit and receive data signal elements, respectively. The connections to these outputs are reversible, so that either or both the send and receive circuits can be controlled from external timing signals, as an alternative to those generated in the analyzer.

The send and receive circuits are also provided with blocking signal inputs. Blocking signals at these inputs can be used to start and stop the send and receive circuits individually, and thereby enable transmission to take place bit by bit. Hence, it is possible to use the analyzer for making measurements on data-communication systems that do not allow a continuous flow of data. This applies mainly to systems that employ the retransmission method for error correction. Timing signals having periods that correspond to a character or a block are also

generated in the receive circuit. Each set of measurements is started and stopped either by operating a built-in push button or remotely by an external connection to a special input terminal provided for the purpose. As in earlier analyzers, the test program can consist of a repeated 8-bit character having a preselected composition, or a cyclic repetitive program. This program can be the same as that used in Felix and Felinda (256 different 8-bit characters), but in the normal Era construction it consists of 128 different 7-bit characters each having a parity bit for odd parity check.

The number of test signal blocks received during the measuring period is registered by an electromechanical counter. Each signal block consists of 1024 bits. The receive circuit is equipped with two electronic decade counters and an electromechanical counter for registering the number of faulty elements received. The errors registered by the decade counters are indicated on pointer-type instruments, while the electromechanical counter registers the number of hundreds of errors. Two outputs are provided to indicate separately the number of positive and negative signal elements received in error.

For measurements over a telephone line, the carrier detector in the telephone modem can be connected to a special input provided in the

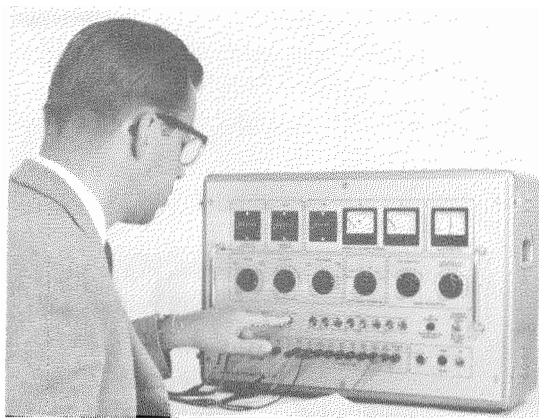

Figure 2—Era error-rate analyzer.

Era analyzer. The measurements will be stopped each time an interruption of the carrier continues for longer than 300 milliseconds. As soon as the carrier is restored the Era receive circuits are automatically resynchronized, after which the measurements recommence. Hence the number of errors registered will include only those that occur during the time a connection is maintained in accordance

with the rules defined by the International Telegraph and Telephone Consultative Committee. A counter in the analyzer registers the number of line interruptions.

When polarity error measurements are made, check pulses are generated that occur in the middle of each received signal element. This applies even in cases where the bias distortion

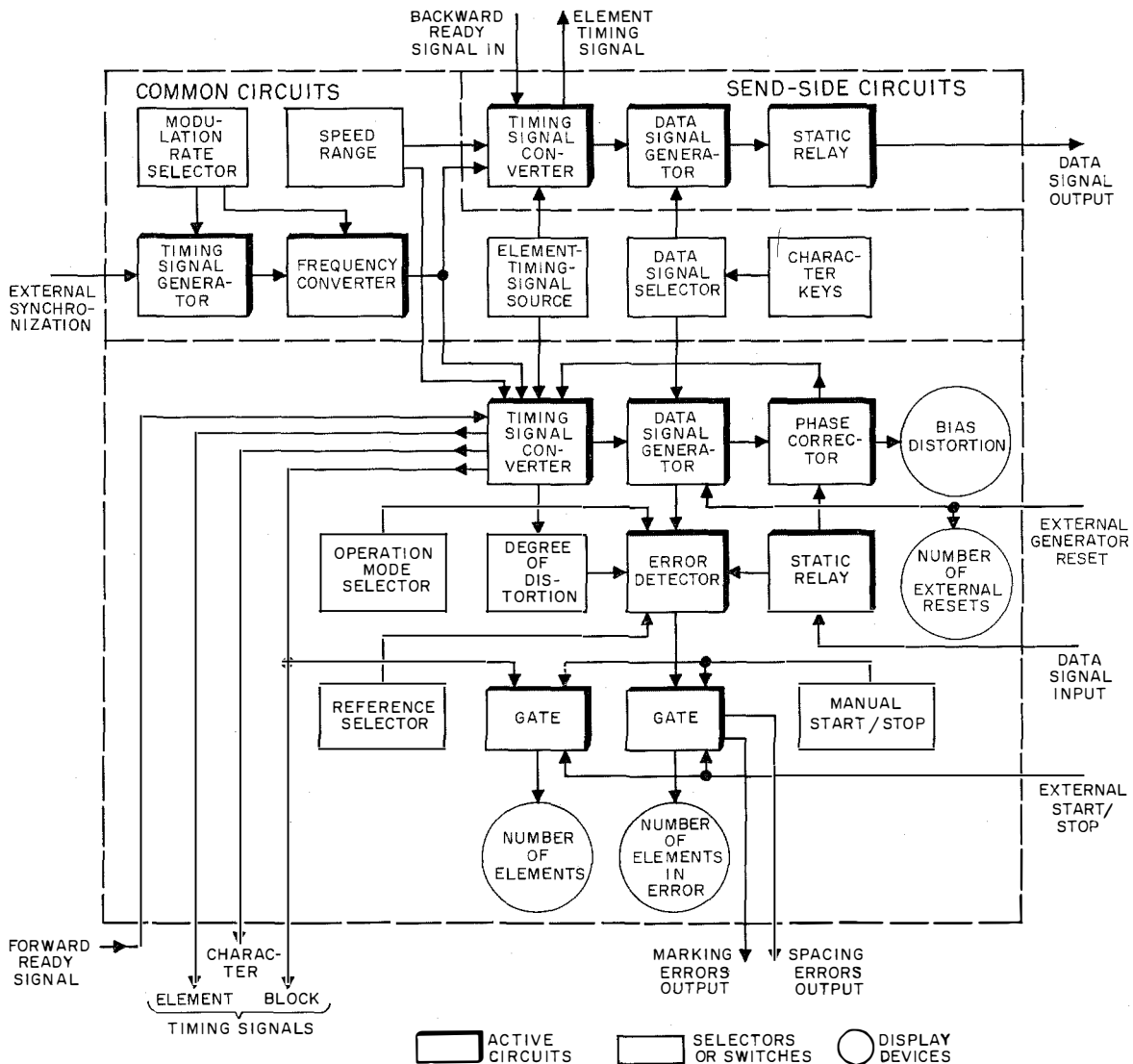

Figure 3—Block schematic of the Era equipment.

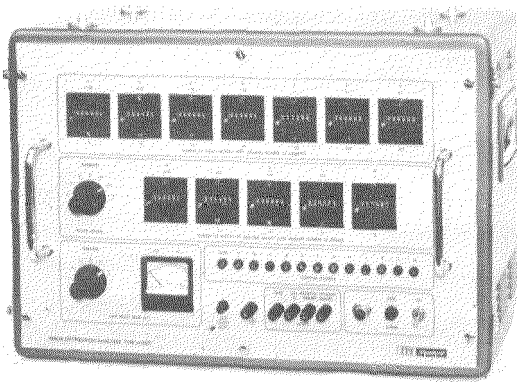

Figure 4—Eda error-distribution analyzer.

is high, that is, when the lengths of the positive and negative elements are asymmetric. With the help of the check pulses, the received data signals are compared with signals obtained from a reference generator in the receive circuits. These reference signals are automatically held in synchronism with the received data signals.

When distortion measurements are made, gate pulses are generated instead of check pulses. The width of these gate pulses can be selected by a switch calibrated in percentage. 100 percent is equivalent to the length of a signal element, and the width of the gate pulse can be selected in steps of 0.5 percent for transmission speeds below 300 bits per second. Pulse widths in steps of 5 percent can be selected for higher transmission speeds. By the use of the gate pulses it is possible to detect if the received signals pass through zero (change polarity) outside the predetermined distortion limit. This method makes it possible to measure not only the characteristic distortion, but also the "conventional degree of distortion." The latter term means a degree of distortion that will be exceeded with a stipulated probability. With the Era analyzer it is possible to measure such an error probability (that is, the error rate) as a function of the degree of distortion.

When distortion measurements are made, the receive-circuit reference signals may be replaced by reference signals obtained by regenerating the received data signals. The change-over is made by means of a toggle switch on the front of the analyzer. It is thus possible to measure the distortion of transmitted data, the information content of which is unknown.

The bias distortion is indicated by a zero-center meter calibrated over the range from +100 to -100 percent. The sensitivity of the meter can be increased tenfold by pressing a button, in which case the full-scale deflections are ± 10 percent.

5. Eda

An error distribution analyzer, which is shown in Figure 4, was developed as a complement to Era. This analyzer is called Eda, this name being obtained by taking the initial letters of error-distribution analyzer, and it has the code number *M1005*. As it was considered that the use of this analyzer would be somewhat restricted, only a limited number were manufactured, and these have been delivered to Swedish and foreign customers.

Eda receives error-indication pulses and timing signals from Era and provides information in two different ways about how the errors are distributed within the transmitted data. One set of registers records the number of faulty blocks containing 8, 16, 32, 64, 128, 256, and 512 bits that are received during one measurement; and another set of registers records how many blocks of any one length, selected from those given above, contain 1, 2, 4, 6, or 8 faulty bits. The desired block length is selected by means of a rotary switch. In certain cases one or two electronic decade counters are required to obtain the necessary recording speed. These counters are read on a common indicator connected to the respective decade counter by means of a rotary switch. In all other cases electromechanical counters are used for registration.

6. Epa

Epa is the latest addition to the error-rate analyzers; it sends and receives data signals in parallel form. Only one model of this analyzer has so far been manufactured. It was introduced as a direct result of the development of a modem equipment intended for the transmission of data in parallel form.

The analyzer includes a send circuit plus a receive circuit for 8 data channels and a timing channel. Both the send and receive circuits contain a data signal generator that generates a cyclic repetitive data block of random construction.

7. Fido

Fido has been developed to complement the error-rate measuring sets previously described. It is called a line-envelope delay simulator and has the code *GH-9101*. Fido is constructed as a 4-terminal network that can be switched into the circuit by means of two rotary switches. It

is possible to simulate the phase characteristics of different types of lines by switching in the appropriate sections of this network. In this respect the test set is equivalent to a 2-way line having balanced input and output impedances of 600 ohms.

One of the switches can be used to connect sections of the network that correspond to 0, 1, 2, 3, or 4 carrier sections. The other switch can be set to any of 6 positions, each position switching in sections of a network that correspond to loaded cables of a certain length.

A phase curve that accurately corresponds to the phase curve of normal carrier sections has been used for the carrier sections of the network. The phase curves, used for the 6 loaded-cable network sections, have been derived by taking the weighted mean value of a number of cables in general use with different grades of loading. Each section of the loaded-cable network produces an envelope delay difference of 1 millisecond within the frequency band from 300 to 3000 hertz.

B. Lindström. Biography appears on page 148.

Error Detection and Correction in Low-Speed Data-Transmission Equipment

H. SAUER

Standard Elektrik Lorenz AG; Pforzheim, Germany

1. Introduction

An error-detecting data-transmission equipment developed by Standard Elektrik Lorenz for telegraph half-duplex circuits is called Thedar. Two versions have been developed—a manual system operating at 50 bauds, and an automatic system operating at 50, 75, 100, and 200 bauds.

2. Manual Version, GH 111

The *GH 111* is connected between the subscriber box and the teleprinter. The same equipment is used for both transmission and reception. Figure 1 shows a laboratory model of a subscriber station with error-detection equipment.

The telex call is set up between the caller and the called subscriber in accordance with the procedure recommended by the International Telegraph and Telephone Consultative Committee for setting up a telex call and its super-



Figure 1—Subscriber station with laboratory model of *GH 111* error-detection set.

vision by exchange of answer-backs. If either subscriber wishes to introduce data-transmission equipment into the connection, he transmits the sequence *SSSS* (combination 19 from International Telegraph Alphabet 2) as the switch-to-data signal. On receiving this sequence of characters the terminal equipments are automatically connected to the line. At the receive terminal all transmission facilities (keyboard, answer-back unit, tape reader) are blocked. The direction of the data flow is determined by pressing the Transmit and Receive push buttons at the respective terminal stations.

Data may be transmitted either by teleprinter keyboard or by teleprinter tape transmitter. The information has to be divided into single blocks of any chosen length.

The blocks are identified automatically with 3 sequence designations (*Y*, *I*, and *O*) in a cyclic manner to avoid undesired repetitions or omissions of blocks. Each block is requested by the receiver using the sequence designation assigned to this block. In this way a truly compelled system results, leaving no doubt which block has just been transmitted and which must follow next.

The end of a block is marked by a signal formed by 4 characters (Letters, Carriage Return, Letters, Carriage Return) which have to be transmitted by the operator. After this end-of-block signal, a 12-bit check signal that was formed in a feedback shift register in response to the data bits in the block will be transmitted automatically. The generation of a check signal by use of a cyclic code was initially sug-

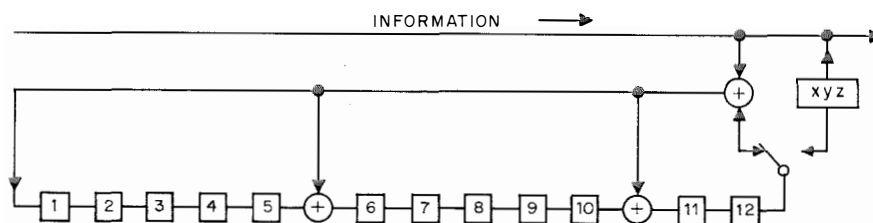

Figure 2—Feedback shift register.

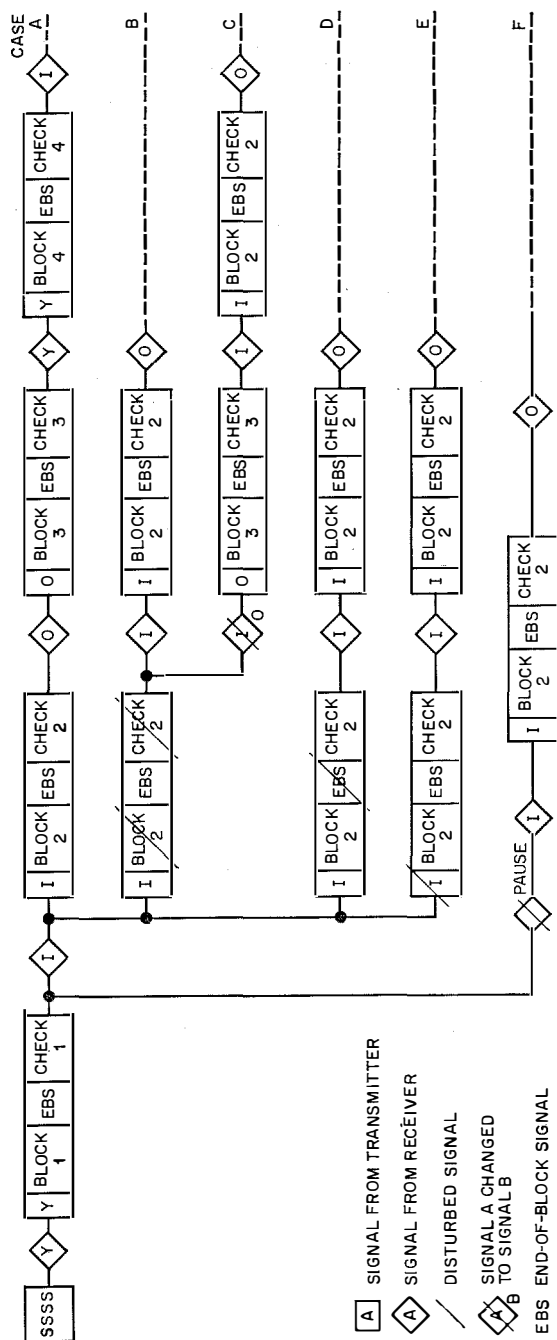

Figure 3—GH 111, block sequence diagram for various faults.

gested by Huffmann [1] and later thoroughly investigated by Elpas [2] and Meggitt [3].

Figure 2 shows the block diagram of such a feedback shift register. At both sending and receiving stations such a shift register is connected to the information path. The shift pulse is in synchronism with the bit rate of information flow. All 0 bits of the block are counted by inverting all the data bits so that the new 1's coincide with the shift pulses to the register and are counted. This inversion is not indicated in Figure 2.

The 12 check bits are grouped into the 5-unit combinations in such a way that the first 4 elements of each character are used for the redundancy bits. The fifth elements of these three characters are used to produce printable combinations in International Telegraph Alphabet 2 by requiring the fifth elements to be of opposite polarity to the first elements.

The idle position of the shift register is "all 0," but it is preloaded with a single 1.

Such a cyclic code with 12 check bits provides protection for a block of $2^{11}-1 = 2047$ bits with a Hamming distance $d = 4$. Only one block of $2^{12} = 4096$ erroneous blocks remains undetected on the average, but every erroneous block with not more than 4 wrong bits is always detected as faulty.

The check signal transmitted to the receiver is compared there with a check signal produced locally. If they are found to be identical, the receiving station will call for the next block by sending the next sequence designation.

Figure 3 shows the procedures in the different possible cases of disturbance.

Case A shows normal operation. If the switch-to-data signal is not answered, it has to be repeated manually.

Case B shows block 2 or check 2 disturbed, therefore no coincidence of the check signals. Block 2 will be requested once more by sequence designation I.

Case *C* shows backward sequence designation *I* is changed into *O* by disturbance, therefore block 3 will be transmitted. The receiver calls again for block 2 and at the same time an optical alarm signal is given, because now the transmitting tape has to be withdrawn manually for 2 block lengths.

Case *D* shows the end-of-block signal of block 2 disturbed, therefore no backward sequence designation is given. After a certain time the receiver requests retransmission of block 2 by backward sequence designation *I*.

Case *E* shows the forward sequence designation of block 2 disturbed. The receiver does not accept the block and calls for block 2 again.

In case *F* the backward sequence designation is suppressed and the transmitter waits until it is repeated by the receiver.

In case of a detected error, the receiving station requests the same block again. Therefore at the sending station the tape has to be withdrawn manually for several characters more than 1 block length. (This procedure facilitates the reinsertion of the tape.) Then the tape transmitter has to be started again. The printed copy therefore shows the erroneous block, a

Figure 4—*GH 111*, printing sample of received message. The transmission of block *O* was disturbed; the end of the previous block is then reprinted (line 7) followed by the corrected block.

```

ssssyy
the quick brown fox
ii
jumps over the lazy dog
oo
the quick eewn fox
ooy dog
oo
the quick brown fox
yy
jumps over the lazy dog
ii
xxxx
    
```

small part of the previous block, and at last the repeated block.

Figure 4 gives a printing sample. Only the sequence designations are printed out, while the check signals are suppressed.

The end of the data transmission is marked by the character sequence *XXXX* (combination 24 of International Telegraph Alphabet 2). After this signal both terminals switch to the normal telex position to continue teleprinter communication or to close the connection.

Figure 5 shows the block diagram of the *GH 111*.

3. Automatic Version, *GH 110*

As stated above, the manual version of Thedar is intended for operation with standard teleprinter equipment at 50 bauds. In the future, the demand for equipment able to work at telegraph speeds up to 200 bauds will increase. As standard teleprinter equipment cannot operate this fast, separate tape readers and punches have to be used for data transmission at 200 bauds.

Taking the experience gained during the development of the manual version as a basis, another version of Thedar was developed, the *GH 110*, which repeats erroneous blocks automatically.

Figure 6 shows at the left the *GH 110* equipment with the built-in tape reader, and at the right a *DP30R* tape punch designed for operation at 30 characters per second.

The terminal equipment has to be completed by a subscriber box for setting up the connection.

The equipment is intended for operation in telegraph half-duplex circuits with a single current of 40 milliamperes. It can be switched to telegraph speeds of 50, 70, 100, and 200 bauds. Any 5-unit start-stop code may be used.

Figure 7 gives the block diagram of a subscriber station. In the idle position the equip-

ment is switched to Receive. Transmission starts after pressing the push button "Start of Transmission" for unprotected transmission or "4XS" for protected transmission. Unprotected transmission starts the tape reader at once. For protected transmission the sending station first transmits automatically the sequence SSSS. This switches in the error-detecting circuits at both terminals. Then the receiving station calls for the first block by transmitting the first sequence designation Y. This is retransmitted by the sending station followed immediately by the first information block. Contrary to the manual version, the automatic version uses fixed block lengths of 240 bits. Therefore no end-of-block signal is necessary.

A counting circuit stops the tape reader as soon as a block length of 240 bits has been reached. Now the check signals, formed in the feedback shift register, are transmitted and compared at the receiver with those locally generated. If the check signals coincide with each other, the next block I is requested by the receiving station. This procedure goes on until all information has been transmitted. The equipment is switched off by pressing the push button "End

of Transmission." This causes the sequence XXXX to be transmitted. This signal switches off the protecting circuits and the equipment returns to its idle position.

If the comparison of check signals fails to give coincidence, the receiver requests repetition of this block by sending its sequence designation back to the transmitter. This signal causes the tape to be reversed for one block length, while at the same time the tape punch also reverses for one block length. The erroneous block is

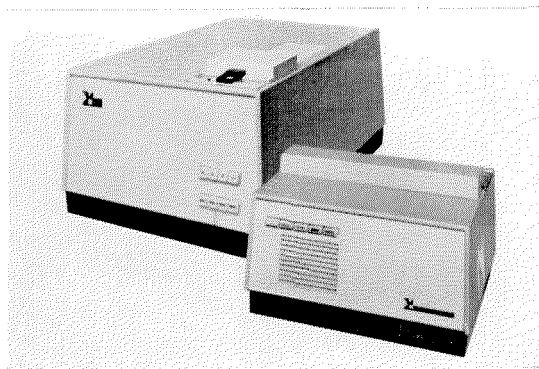

Figure 6—Data transmission terminal, GH 100 and DP30R.

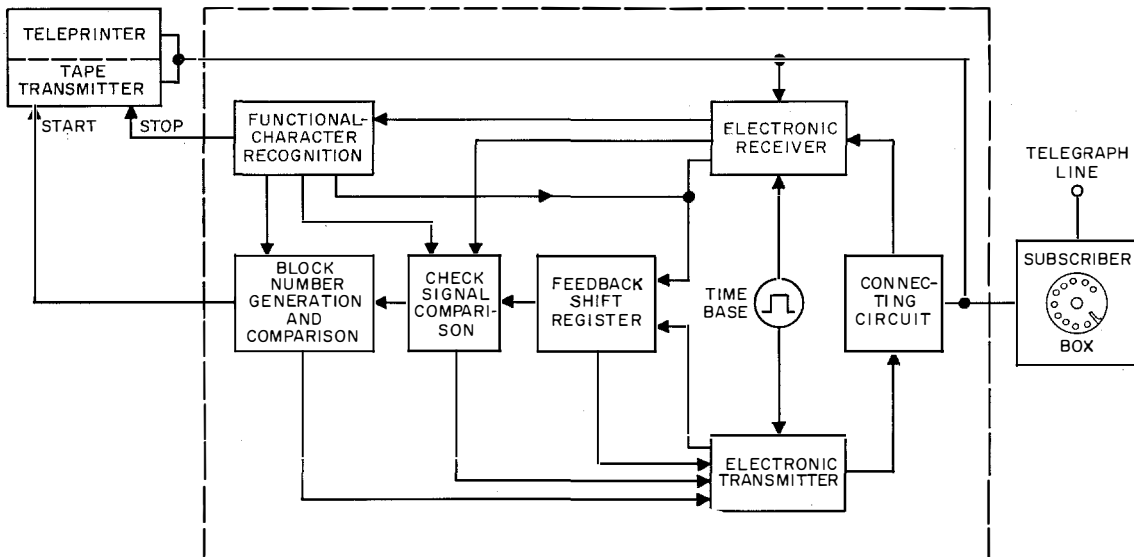

Figure 5—GH 111, block diagram.

Error Detection and Correction in Low-Speed Data

then overpunched by the "all-hole" combination (combination 29 of International Telegraph Alphabet 2). After this operation has been finished, the sequence designation is repeated by the receiver, whereupon the transmitter starts to repeat the block, which is followed by the normal check procedure. A letter and figure storage in the receiver provides, before repetition of the block, the shift combination that was used in the beginning of the disturbed block.

The tape punched at the receiving station is called a corrected tape, because it contains the overpunched erroneous blocks in addition to the correct transmitted information. Also the sequences SSSS and XXXX are punched out but all other functional signals are suppressed.

Figure 8 shows the operation procedure.

Case *A* shows normal operation. If the switch-to-data signal is not answered, it will be repeated automatically.

Case *B* shows block 2 or check 2 disturbed, therefore no coincidence of the check signals occurs. Repetition of block 2 is requested by sequence designation *I*.

Case *C* shows repeated backward sequence designation *I* is changed into *O*, therefore block 3 will be transmitted. The receiver does not accept block 3 and calls again for repetition of block 2.

Case *D* shows forward sequence designation *I* disturbed. The following block 2 will not be acknowledged because it is not numbered. The receiver calls again for block 2 by backward sequence designation *I*.

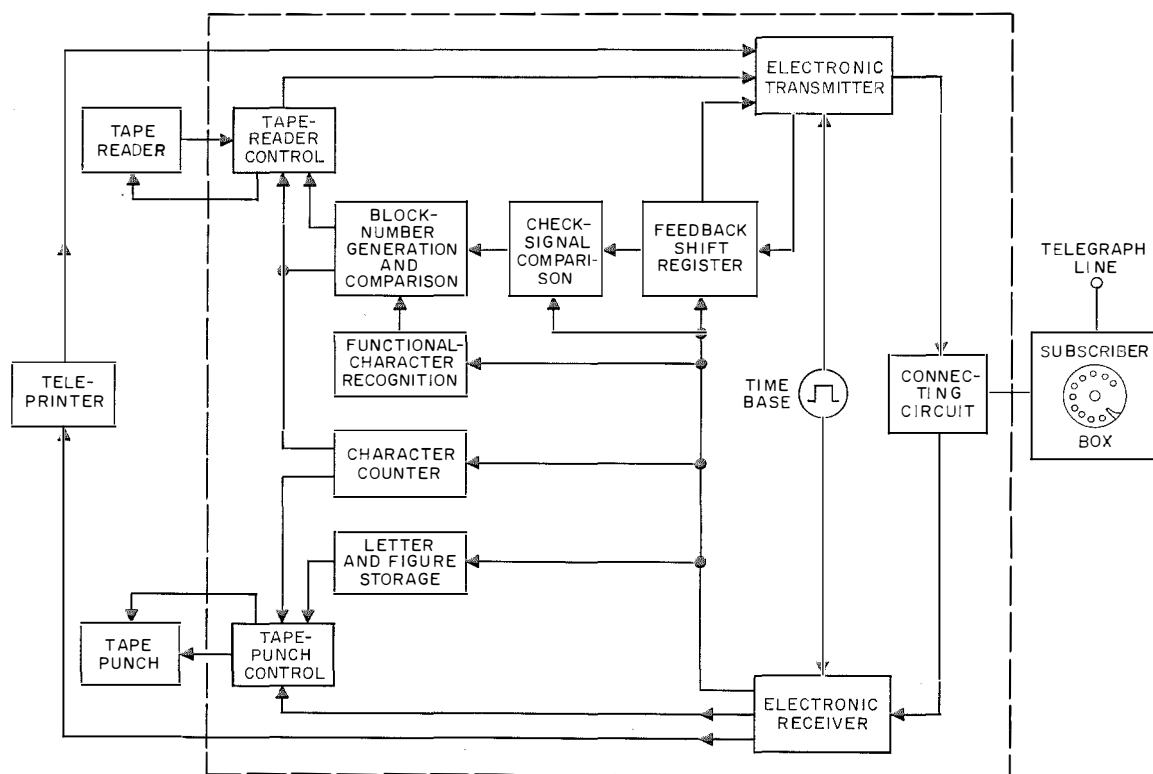

Figure 7—GH 110, block diagram.

In case *E* the backward sequence designation is suppressed, and the transmitter waits until it gets the correct sequence designation; this has been repeated by the receiver because it was not acknowledged by the transmitter.

If the transmission of a block is interrupted for some time, the character counters in both terminals will not operate in synchronism. The block end will therefore be fixed at the sending station earlier than at the receiver. If the receiver does not receive additional characters after 1.5 seconds, its character counter is automatically filled up to 240 bits. There is then no coincidence of the check signals and retransmission of this block is requested.

3.1 GENERAL TECHNICAL DATA

The power supply operates from 110 or 220 volts alternating current. Power consumption is 40 watts. The circuits are all solid-state, and the constructional layout complies with the standard equipment practice for ITT Europe [4]. Ambient temperature limits are -10 to +40 degrees Celsius. Dimensions are 270 x 340 x 600 millimeters (10.6 x 13.4 x 23.6 inches). The weight of the *GH 110* is 22 kilograms (48.4 pounds).

3.2 FUTURE ELABORATIONS

It seems necessary to increase the fixed block length of the *GH 110* from 240 bits to 480 or 560 bits for compatibility with other equipment and to meet customer wishes. In addition, a modified version of the *GH 110* will be developed to allow the transmission of 8-unit codes, as the use of such codes will increase substantially in the future.

In the existing equipment space has been provided to incorporate circuits for the detection of errors generated in the input and output equipment. For this purpose the tape reader can be equipped with a double reading station, while in the punch unit contacts are controlled by the movement of the punch needles, and this control may be used for coincidence circuits.

The circuits of the *GH 110* have been designed as two parts. One part comprises the connecting circuit to the line, the control circuits for tape reader and tape punch, the parallel-serial converter and vice versa, and finally the time base. The second part consists of the error-detection circuits, functional-character generation and detection, character counter, and letter and figure storage. By making use of only the first part it is possible to design a very inexpensive data-transmission terminal. A 50-baud and a 200-

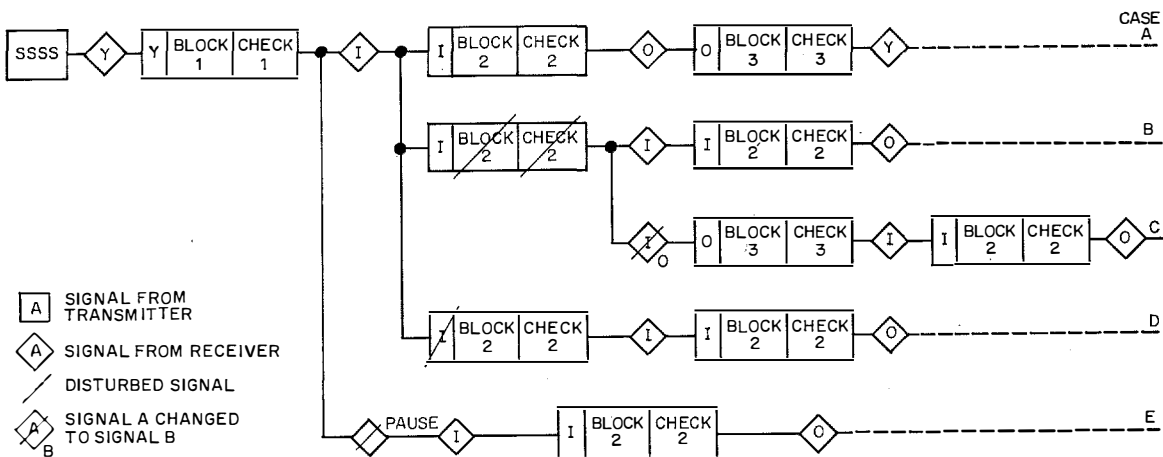

Figure 8—*GH 110*, block sequence diagram for various faults.

Error Detection and Correction in Low-Speed Data

baud line with such terminals was demonstrated at the 1965 International Transport Fair in Munich, Germany.

4. Summary

Two equipments for error detection, operating with decision feedback on low-speed half-duplex telegraph connections, have been described. Error detection is achieved by putting the information to be transmitted into a feedback shift register at the sending station as well as after reception at the receiving station. The check signals formed in the two shift registers are then compared. With coincidence, transmission goes on, otherwise the erroneous block will be repeated.

The information is transmitted in blocks, the manual system operating with any selected block length and the automatic system with fixed block length.

The manual system *GH 111* is intended for operation at 50 bauds. The automatic system *GH 110* can be switched to operate at 50, 75, 100, or 200 bauds.

Both systems improve the error rate by 4×10^3 ; that is, with 8 hours service per day at 50 bauds, an error now occurs only once per year [5].

H. Sauer was born on 29 March 1929 in Stuttgart, Germany. In 1955 he received the Dipl. Ing. degree in electrical engineering from the Technische Hochschule in Stuttgart.

In 1954 he joined Standard Elektrik Lorenz,

5. Acknowledgment

The author gratefully acknowledges the co-operation of Mr. H. Hannig of Standard Elektrik Lorenz, Pforzheim, in preparing this paper.

6. References

1. D. A. Huffman, "A Linear Circuit Viewpoint On Error Correcting Codes," *IRE Transactions on Information Theory*, volume IT-2, number 3, pages 20–28; September 1956.
2. B. Elspas, "The Theory of Autonomous Linear Sequential Network," *IRE Transactions on Circuit Theory*, volume CT-6, number 1, pages 45–60; March 1959.
3. J. E. Meggitt, "Error Correcting Codes and their Implementation for Data Transmission Systems," Delft Symposium; 1960.
4. F. Beerbaum, J. Evans, and F. Leyssens, "Standard Equipment Practice for ITT Europe," *Electrical Communication*, volume 39, number 2, pages 199–211; 1964.
5. International Telegraph and Telephone Consultative Committee, Special Study Group A, Contribution Number 34; 16 November 1961. Also Contribution Number 92; 18 October 1963.

where he was engaged in the development of transfer exchange equipment for coast radio stations, as well as voice-frequency telegraph equipment. Since 1962 he has been technical assistant to the manager for development and engineering of the Data Systems Division.

Dynamic Measurements of Magnetic Thin Films

J. M. TYSZKA

Laboratoire Central de Télécommunications; Paris, France

1. Introduction

The qualities of a magnetic thin film concerning its use as a memory element are characterized by a certain number of its parameters. The most direct and useful information about these qualities is obtained from dynamic measurements made under conditions that simulate real operation in a memory. Moreover, these measurements make it possible to obtain precious experimental information on phenomena that have not yet been fully explained theoretically.

A dynamic-measurement apparatus was constructed to test plane areas of magnetic thin films not equipped with access conductors, for the dispersion angles of the easy magnetization axis, the output characteristics (values of the output signal with respect to the applied fields), and the sensitivity to the creep effect.

These measurements make it possible not only to select good films, but also to determine the values of access currents, the tolerances on these currents, and the values of the output signal, with respect to the dimensions of the access conductors of a real memory.

A discussion of the principles of the measurements is followed by a description of a measuring set, which has been called a creepmeter.

2. Principle

2.1 ANGULAR DISPERSION

In Figure 1, take a system of coordinates of reference (x, y) the axes ox, oy of which are parallel to the edges of the magnetic film plane; they thus lie in the desired directions of the easy and hard magnetization axes.

The sample is submitted to the magnetic driving field H_{cm} . The amplitude of this field is sufficient to align the magnetization vector M of the entire volume concerned in the direction H_{cm} . The vector H_{cm} forms a variable angle β with the axis oy . To better simulate the dynamic conditions, the field H_{cm} will be created by a current pulse train I_c the amplitude, repetition frequency, duration, and rise time of which will correspond to a real case of memory operation.

After each pulse, the magnetization vector M of the sample will return to the preferential state 0 or 1 depending on the sign of the angle $\alpha = \beta - \beta_0$, where β_0 is the angle between the average local easy axis and the reference axis ox (Figure 1).

For the small values of $|\alpha|$, the film will divide into fragments as the result of the angular dispersion of the anisotropy direction on the microscopic scale, characterized by the angle α_{90} , for which 90 percent of the magnetization will be found in the same remanent state.

The characteristic of the variations of the output signal amplitude e_0 is plotted versus β (Figure 2), which enables us to determine the values β_0 and α_{90} . The measurements can be limited to the three points of the characteristic corresponding to β_0 (cancellation of the signal) and $\pm\alpha_{90}$ (90 percent of the maximum signal).

2.2 OUTPUT CHARACTERISTICS

The sample is submitted to two orthogonal fields: the driving field H_{cm} parallel to oy the amplitude of which is adjustable, and the information field H_i parallel to ox of variable amplitude (positive or negative).

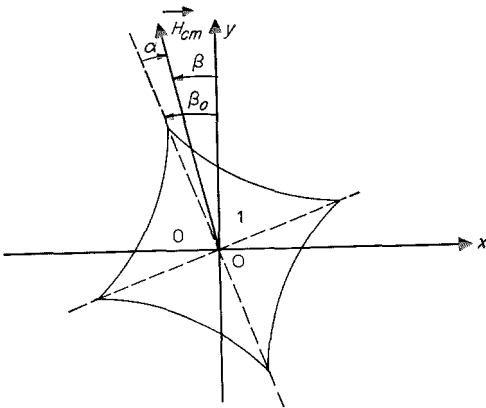

Figure 1—Principle of angular-dispersion measurements.

Dynamic Measurements of Magnetic Thin Films

These fields are created, respectively, by pulse trains of current I_c and I_i , which simulate the word and digit currents of a linear selection memory for all the temporal parameters (repetition frequency, position in time, duration, and rise time).

The family of the output characteristics is plotted in Figure 3:

$$e_o = f(H_i) = f(K \cdot I_i)$$

$$H_{vm} = K \cdot I_c = \text{parameter}$$

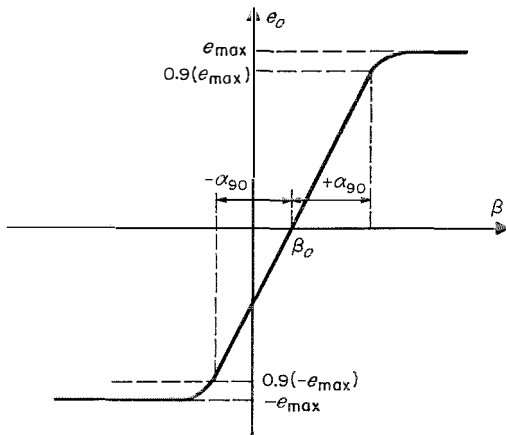

Figure 2—Angular dependence of output signal amplitude.

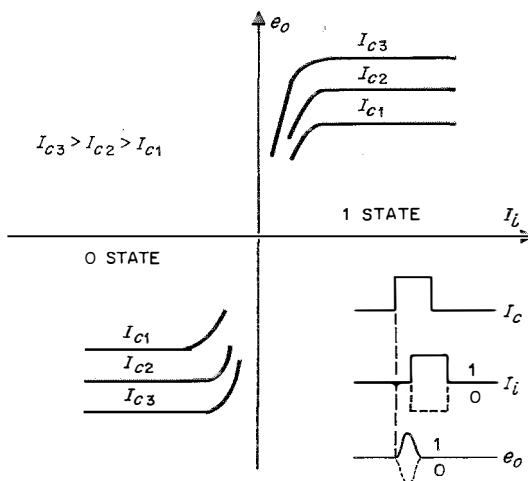

Figure 3—Output characteristics of a magnetic thin-film sample.

where K is a coefficient of proportionality. It is possible also to plot the family of the complementary characteristics as in Figure 4:

$$e_o = f(H_{vm}) = f(K \cdot I_c)$$

$$H_i = K \cdot I_i = \text{parameter.}$$

2.3 CREEP EFFECT—DISTURBED OUTPUT CHARACTERISTICS

The creep effect appears as the progressive modification of the remanent magnetization stored in a magnetic thin-film cell, following the repeated application of a certain number of magnetic-field disturbing pulses the direction of which forms an angle comprised between $\pi/2$ and $3\pi/2$ with the quiescent direction of the magnetization vector. A cumulative effect is found; each disturbing pulse taken individually would have no appreciable effect.

The creep effect seems to be related to Bloch wall motion [1, 2] and its existence depends on the intrinsic characteristics of the magnetic films. It has been announced [3] that, for a given film, the factors acting on the creep effect are: the number of disturbing pulses; their width, frequency, and rise time; the amplitude of the disturbing field they create; and the direction of this disturbing field.

In a linear-selection random-access memory operation, the disturbing pulses correspond to the information pulses destined for addresses other than the address under consideration. Their amplitude, width, and rise time are therefore those of the information pulses, their number can be very high, and their direction—in the unfavorable case—is opposite to the direction of the recorded information pulse. Moreover, the leakage field of the neighboring word can give a transverse component to the disturbances.

The dynamic-measurement method adopted simulates this operation. The sample is submitted to two orthogonal fields as for the preceding measurement (Section 2.2); but the information field pulse H_i is now followed by

a series of disturbance field pulses H_p having the opposite polarity, the number N of which is variable. The train of N pulses I_c' creates the perturbations of the neighboring word (see Figure 5).

The family of the disturbed output characteristics is plotted in Figure 5.

$$e_o = f(H_i) = f(K \cdot I_i)$$

N = parameter

for the nominal value of H_{cm} and $H_p = -H_i$.

The rapid measurement consists of reading the four points: $+I_{imin}$, $-I_{imin}$, $+I_{imax}$, $-I_{imax}$ for $e_o = \rho \cdot e_{max}$ ($0 < \rho < 1$) with, for example, $\rho = 0.8$ (Figure 5). We shall define the figure of merit η of a sample as being the ratio

$$\eta = \frac{\text{minimum value of all the } (+I_{imax}, -I_{imax})}{\text{maximum value of all the } (+I_{imin}, -I_{imin})}$$

Obviously, the value of η will depend on N , ρ , and on the dimensions of the spot that determine the demagnetizing field.

3. Apparatus

The two separate units that make up the dynamic-measurement apparatus are shown in Figure 6. At left, is a mechanical positioning device equipped with a probe to simulate all the access conductors of a memory point. At right, is a programed pulse generator that delivers to the probe all signals necessary for the measurements.

3.1 POSITIONING DEVICE

The plate to be measured is mounted on a tray affixed to a carriage that provides for translation movements in two perpendicular directions. A main grid, set in position by two micrometer screws, precisely indicates the points tested.

The sample moves underneath a probe that is adjustable in distance from the surface and in

angular position. A vernier permits reading the angles to within 0.2 degree. A pneumatic actuator is provided to raise the probe.

The extremity of the probe is equipped with 2 groups of orthogonal flat conductors, which

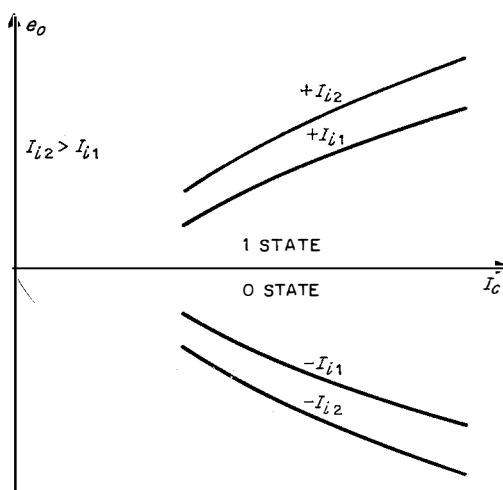

Figure 4—Complementary output characteristics.

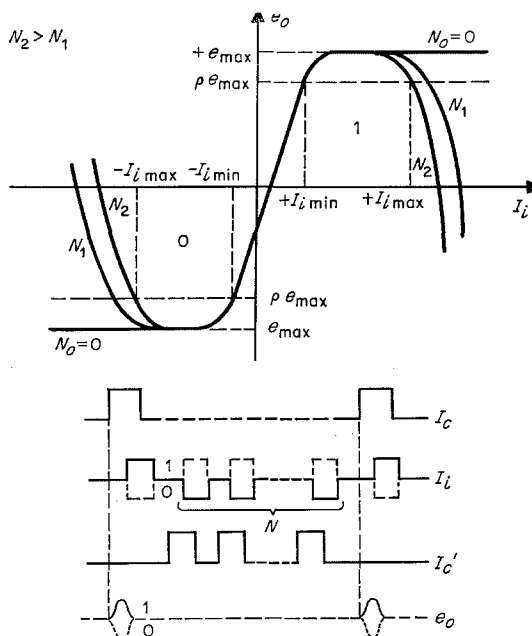

Figure 5—Disturbed output characteristics.

Dynamic Measurements of Magnetic Thin Films

by their dimensions simulate 3 consecutive words and 3 consecutive digits of a memory. These conductors are supplied by the programmed pulse generator and produce the fields, the values of which are easily computed with respect to the corresponding currents and the dimensions of the system.

A small sense winding, placed above the conductors, detects the flux variations caused by the rotation of the magnetization in the plane of the film. The induced voltage is amplified and observed on an oscilloscope. A compensation system eliminates the stray signal produced at the moment of the readout by the leading edge of I_c . Its efficiency can be appreciated on the photograph of the readout signals of a 0 and of a 1 (Figure 7). The reduced vertical-deflection factor at the level of the sample is

0.25 millivolt per division, and the horizontal-deflection factor is 20 nanoseconds per division.

The use of a sampling oscilloscope equipped with a memory tube makes it possible to plot the output characteristics directly on the screen. The horizontal-deflection plates are supplied by a voltage that is proportional to the amplitude of the information current, and the vertical-deflection plates receive the sampling signal centered at the peak of the sense signal.

3.2 PROGRAMED PULSE GENERATOR

Transistors are used as the active components of the programmed pulse generator.

A variable-speed clock is synchronized by sinusoidal signals, which for internal control are

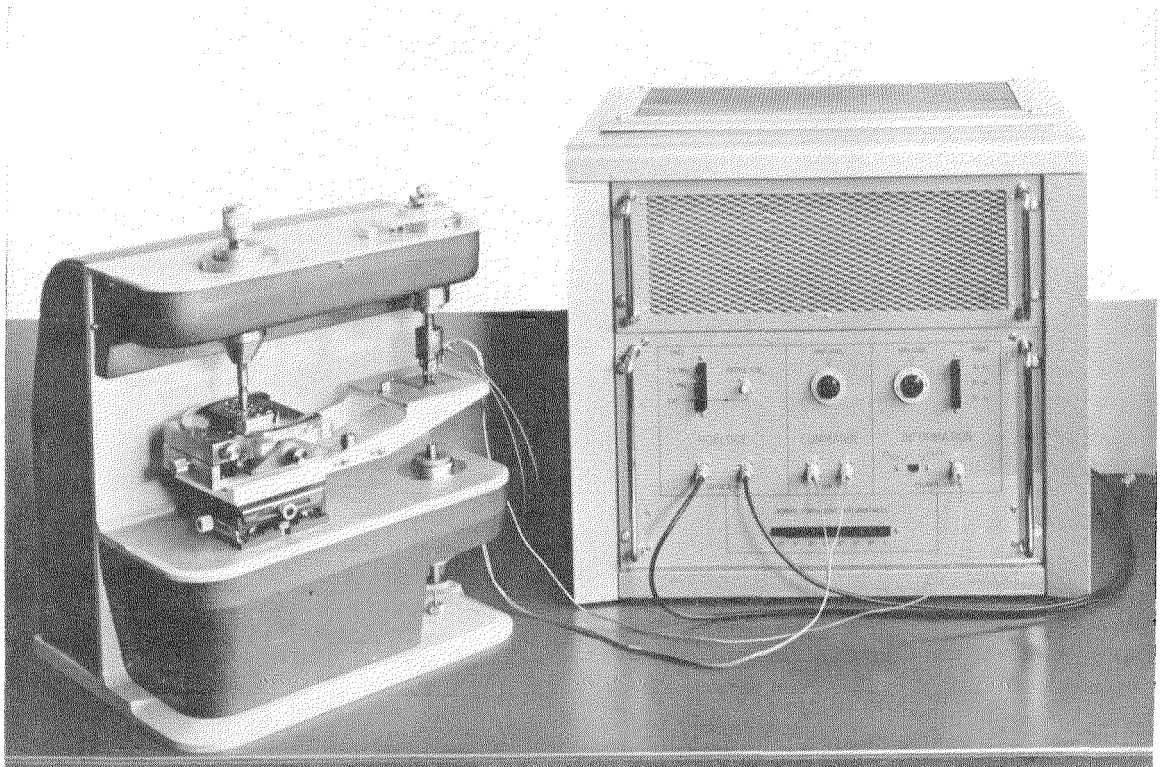

Figure 6—Dynamic-measurement apparatus—the creepmeter.

from an oscillator operating at either 2.5 or 5 megahertz. For external control, the clock can be triggered at a frequency between 1 and 10 megahertz. It is thus possible to simulate a wide range of timing cycles to meet the operating speed of magnetic thin-film memories.

The clock contains counters and logic circuits that enable it to supply as 4 separate outputs: the drive signals, the information signals overlapping the trailing edges of the drive signals, and the disturbance signals of the neighboring word and of the digit that occur between two consecutive information signals, the number N of which is equal to

$$N = 8^n - 1$$

where $n = 0, 1, 2, \dots, 7$, which can be chosen by means of a manual switch.

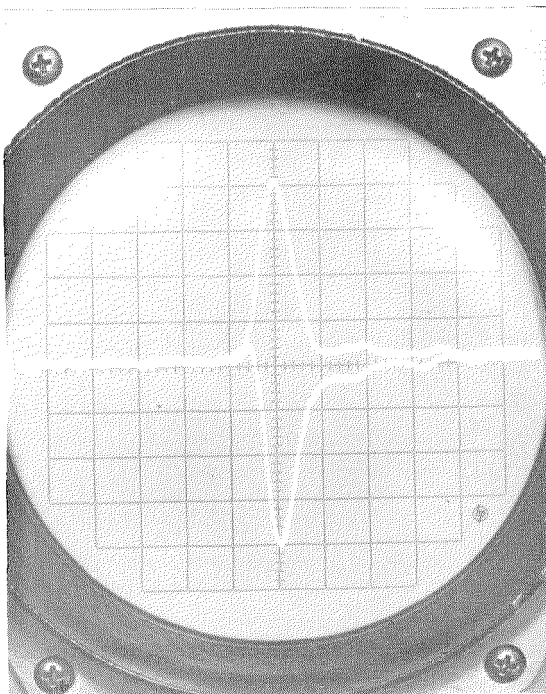

Figure 7—Readout signals of a 0 and of a 1. The horizontal-deflection factor is 20 nanoseconds per division, and the reduced vertical-deflection factor is 0.25 millivolt per division.

A synchronization signal is provided for triggering the oscilloscope before the start of each cycle. The cycle consists of 1 drive pulse, 1 information pulse, and N disturbance pulses.

The clock drives two types of variable-level current pulse generators that constitute the power stages.

(A) The drive generator supplies to a coaxial cable that is short-circuited at the far end current pulses having an amplitude variable between 0 and 1 ampere, with a rise time of 10 nanoseconds, that is independent of the current amplitude. A second generator of this type delivers the perturbation of the neighboring word.

(B) Another pulse generator supplies both information and disturbance pulses, which are always of opposite polarity. Their amplitudes are equal and variable between 0 and ± 350 milliamperes. Their rise time is 10, 20, or 30 nanoseconds, and the duration of the rise time is independent of the amplitude, pulse type, and polarity. This generator is capable of simultaneous inversion of the polarity of the information and disturbance pulses. Its output goes to a coaxial cable that is also short-circuited at the far end.

The coaxial output cables are matched at the output of the generators, which absorb the reflections from the short-circuited far ends that constitute the loads.

Figure 8 shows the signals of the two types of generators. The vertical-deflection factor is 0.2 ampere per division and the horizontal-deflection factor is 100 nanoseconds per division. Figure 9 shows the leading edge of the drive current with a vertical-deflection factor of 0.1 ampere per division and a horizontal-deflection factor of 5 nanoseconds per division. These signals were picked up by an ultra-fast current probe constructed in the laboratory and connected to the short-circuited end of the coaxial output cable. The photographs thus present the shapes of the current pulses at the very place at which they are used.

Dynamic Measurements of Magnetic Thin Films

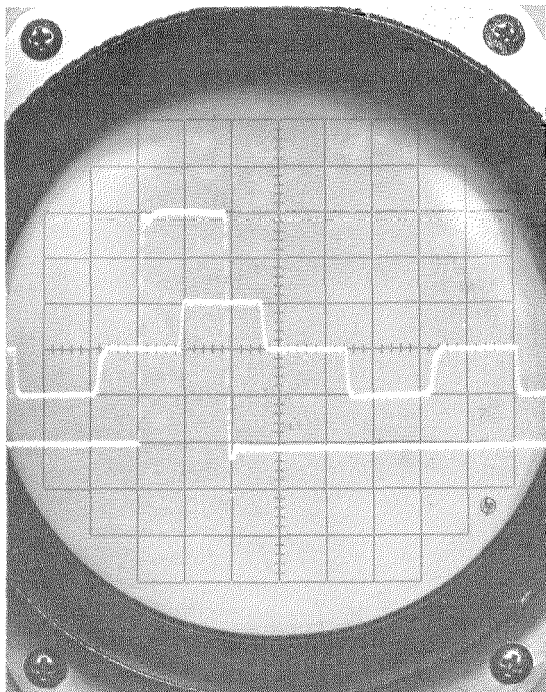

Figure 8—Drive current and composite wave of information and disturbance currents. The horizontal-deflection factor is 100 nanoseconds per division, and the vertical-deflection factor is 0.2 ampere per division.

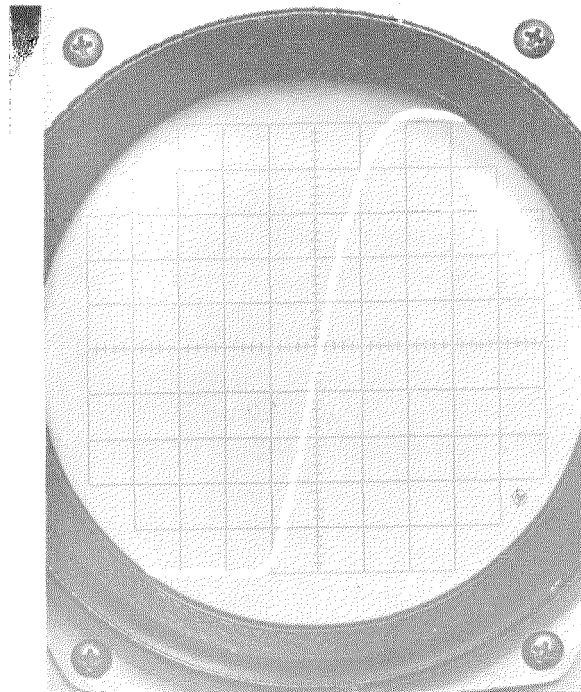

Figure 9—Leading edge of the drive current. The horizontal-deflection factor is 5 nanoseconds per division, and the vertical-deflection factor is 0.1 ampere per division.

4. Applications

The equipment described has been in operation since the beginning of 1964. It is used to make systematic measurements on the planes manufactured in the laboratory. It has contributed to the development of a technology for the preparation of films that are insensitive to the creep effect over a large range of thicknesses (300 to 1500 angstrom units).

The programed pulse generator alone has been used to test complete memories having both plane and cylindrical structures.

A very-good correlation has been found between the results furnished by the apparatus and the film behavior in a fully equipped memory.

J. M. Tyszka. Biography appears on page 176.

5. References

1. A. Green, K. D. Leaver, and M. Prutton, "Origin of Domain Wall Creeping in Magnetic Films," *Journal of Applied Physics*, volume 35, pages 812–813; March 1964.
2. S. Middlehoek, "Relation Between Domain Wall Creeping and the Occurrence of Bloch Lines in Thin Ni-Fe Films," *Physics Letters*, volume 13, pages 14–15; 1 November 1964.
3. W. Dietrich and W. F. Proebster, "A Study of Switching in Thin Magnetic Films," *Digest of Technical Papers*, International Solid-State Circuits Conference, pages 66–67; 1961.

Memory for Test and Evaluation of Magnetic Thin Films

J. M. TYSZKA

Laboratoire Central de Télécommunications; Paris, France

1. General

To compete with the fast memories presently used, particularly ferrite-core memories, magnetic thin films must have technical or economic advantages, or both. Among the technical advantages, the faster working speed should be mentioned; among the economic advantages, there is the possibility of integrated automatic production of entire memory planes as well as of the access conductors.

A very-fast memory of small capacity (10^8 bits) has been built to evaluate the possibilities and the limitations of thin-film memories. It has also proved to be a very-effective test apparatus for measuring the performance of films prepared in Laboratoire Central de Télécommunications, in which particular attention has been given to the problem of reliability, especially concerning the creep effect.

Some general considerations that put the problem in perspective are followed by a description of this memory.

1.1 TECHNICAL CONSIDERATIONS

Numerous descriptions can be found of the working principle of magnetic thin-film memories [1-4] and we shall not go into them here. Let us merely recall that the use of the uniaxial anisotropy of the films generally leads, in the present state of the technology, to destructive reading of the memories with linear word selection ($2D$ memories). The very-high coherent rotation speed of the magnetization vector constitutes one of the main attractions of thin films. However, the minimum value of the memory cycle time is often limited by the very-high ratio of the input power to the output power: the access currents are high, the output signal is low, and the stray signal caused by the information current is stronger than the useful signal by about 3 orders of magnitude. The sense amplifiers must have a high gain, a wide bandwidth, and as short a recovery time as possible after the passage of stray signals of information. So that this recovery time does not

constitute the major part of the memory cycle time, it is indispensable to provide a compensation system for stray signals.

Complete read-write cycle times of less than 300 nanoseconds are currently claimed.

At the present time, several companies have commercialized thin-film memory planes with flat or cylindrical structures. Some of the external characteristics include word currents of 400 to 800 milliamperes, digit currents of 100 to 200 milliamperes, and output signals of the order of 1 millivolt for the flat structure and of the order of 10 millivolts for the cylindrical structure. The announced cycle times vary from 0.1 to 1 microsecond, and the density of the memory cells ranges from 20 to 100 per square centimeter.

The thin films thus offer the advantage of high working speed plus great density of information. Good behavior in temperature and wide tolerances in access currents should also be mentioned. The use of film memories is interesting for ultra-fast systems of moderate capacity and is promising for large capacities and for read-write cycles longer than 300 nanoseconds in that the cost per memory cell is not too high.

1.2 ECONOMIC CONSIDERATIONS

The possibility of automatic manufacture of entire memory planes as well as the access conductors is of particular interest. Once the technology of the films has been mastered and their characteristics made reproducible, the cost of the memory matrixes is potentially very low. With a few moderate investments, the testing of entire planes can be very rapid and entirely automatic.

To obtain the total cost per memory cell, the cost of manufacturing and testing a memory matrix plus the price of the associated circuits should be divided by the number of bits it can store.

The price of fast transistors changes very rapidly and we shall limit ourselves here to

estimating the number of transistors necessary. Let us consider a linear selection memory of w words of d digits that uses a transistor address-selection matrix (this arrangement ensures superior performance). It requires, on the average, (A) in the word direction: m transistors for the selection matrix, $2(m)^{1/2}$ word driver transistors, and $(m)^{1/2}$ gate transistors, and (B) in the digit direction: $6d$ transistors in the sense amplifiers, and $4d$ bipolar digit driver transistors.

Figures 1 and 2 show the computation results

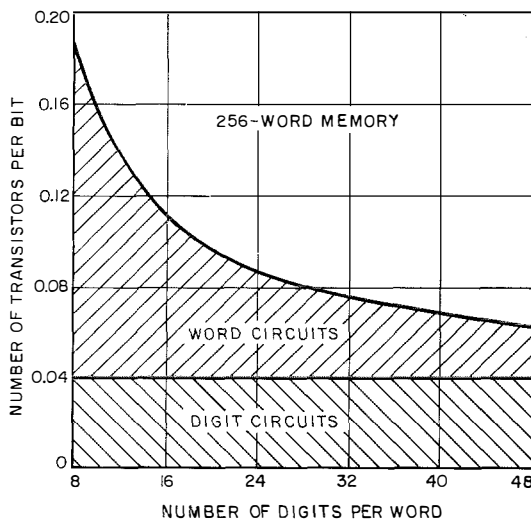

Figure 1—Transistors per bit for a 256-word thin-film memory.

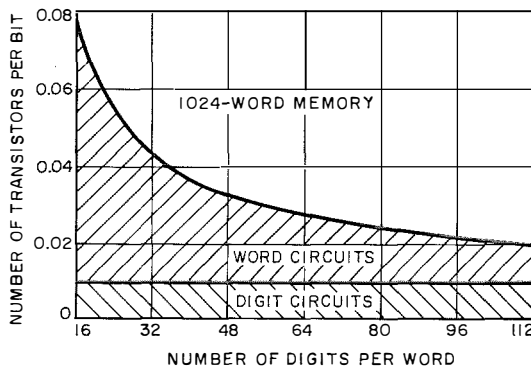

Figure 2—Transistors per bit for a 1024-word thin-film memory.

for memories of 256 and 1024 words, respectively. From these curves, a memory of 10^4 bits requires about 7 transistors per 100 bits, and a memory of 10^5 bits requires 2 transistors per 100 bits.

If we introduce the notion of an average cost of a wired transistor made up of the price of the transistor, the price of the various components associated with it, and of the labor to install these components in the circuit, the estimate cited makes it possible to compute the cost per memory cell.

For larger memory capacities, two solutions are possible. A memory of w words of d digits could be built either with a $w \times d$ matrix or, using a quite-simple supplementary logic, with a matrix having only w/n multiple words of nd digits, where n is an integer that will divide w without a remainder. The choice of n will be made either to improve the working speed, or to reduce the cost. From the point of view of cost per memory point, the optimum ratio will be

$$\frac{w}{d} = \frac{N_d P_d}{N_w P_w}$$

where

N_w = total number of transistors per word

N_d = total number of transistors per digit

P_w = average price of a wired word transistor

P_d = average price of a wired digit transistor,

the values N_w , N_d , P_w , and P_d being taken for a $w \times d$ matrix.

Subassemblies in the form of integrated circuits could give a price decrease. The development of a thin-film memory with coincidence selection (3D memory) [5] would considerably reduce the number of transistors required. However, the working principle itself (uniaxial anisotropy) and the tolerances required make this solution more difficult.

A memory of 64 words of 16 digits each was built to evaluate and test the possibilities of thin films. This memory is described in the following sections.

2. Memory Planes

2.1 CHARACTERISTICS

The memory planes are obtained by vacuum evaporation, in the field of a permanent magnet, of a continuous film of iron-nickel alloy having zero magnetostriction. The size of the glass substrate is $50 \times 50 \times 0.3$ millimeters ($2 \times 2 \times 0.01$ inches). The film thickness is 1500 angstrom units, the anisotropy field H_K is held between 2 and 2.2 oersteds, and the coercive field H_C is held between 2.3 and 2.6 oersteds.

There is practically no magnetostriction, as the composition of the alloy is controlled to within less than 0.1 percent, and the variation of H_K is less than 0.2 oersted for a deformation of the substrate of 0.5 millimeter at the center between two support points separated by 45 millimeters.

Other important characteristics are: the dispersion $\alpha_{90} \leq 1$ degree, and the skew $\beta \leq \pm 2$ degrees.

The planes are systematically subjected to a series of static and dynamic measurements.

2.2 STATIC MEASUREMENTS

The astrometer [6] is an apparatus that displays on the screen of a cathode-ray tube the critical switching curve (astroid) of the magnetic film. It provides a qualitative check of the anisotropy of the film, and measures both the anisotropy field H_K and the skew β .

This apparatus, equipped with a mechanical mounting, determines the composition of the thin-film material by the variation of H_K for a given deformation of the substrate.

The coercive field H_C is measured by means of a hysteresimeter with longitudinal Kerr effect.

The thickness is measured by the interferential method of Tolansky.

2.3 DYNAMIC MEASUREMENTS

The dynamic-measurement apparatus called the creepmeter [7] provides the dynamic pulse

measurements of the memory planes that are not equipped with access conductors. It gives:

(A) The values of α_{90} and of β within $< \pm 0.5$ degree.

(B) The characteristics $e_o = f(I_i)$ with I_i as parameter, and the determination of the value of I_c .

(C) The characteristics $e_o = f(I_i)$ with I_c as parameter, and the determination of the value of I_i .

(D) The test of the creep effect by measuring e_o with respect to the number of disturbing pulses for various values of I_c and I_i .

Here

e_o = amplitude of output signal

I_c = amplitude of drive (word) current

I_i = amplitude of information (digit) current.

3. Access Conductors

3.1 DETERMINATION OF THE GEOMETRY

The memory planes are placed on a metal plate that constitutes the common ground. The access conductors are parallel bands etched in a printed circuit and they constitute, with the ground plane, transmission lines of the strip type. Their width and density are of prime importance since they determine the values of the access currents, the useful fields, the disturbing fields, the dimensions of the memory cells, and thus the values of the demagnetizing fields as well as the amplitude of the output signals.

Detailed computations have given the values of various fields influencing the memory operation with respect to the dimensions of the conductors. An experimental verification consisted of examining with the creepmeter a film equipped with circuits of various sizes to see if the creep effect occurred.

3.2 ELIMINATION OF STRAY SIGNALS

The single double-face printed circuit has all the access conductors in the word and digit

Memory for Test and Evaluation of Thin Films

directions, as well as a final transistor decoding matrix having 1 transistor per word. The same conductors serve to apply the information currents and to sense the output signals.

Figure 3 shows a way to eliminate the stray signals. The word stray signal, induced by the stray capacitance of the crossing surface between the word conductor and the digit conductor, is eliminated by using 2 film spots per memory cell.

The memory planes are grouped by pairs, and a balanced pulse transformer with 6 windings ensures the rejection of the information stray signal. The average rejection ratio is equal to 50 decibels without adjusting the transformers. The information stray signal is thus brought to the same order of magnitude as the useful signal.

An adjustment of the transformers would further improve this result.

4. Memory Organization

Figure 4 shows the organization of the memory. The memory matrix is constituted of a general ground plane, a pair of memory planes, and two families of conductors described earlier. The capacity is 64 words of 16 binary digits each, which gives a density of > 60 cells per square centimeter. A block of 16 pulse transformers is is

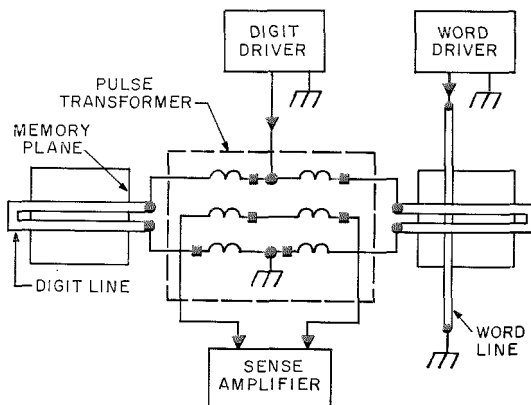

Figure 3—Scheme for eliminating stray signals.

incorporated in the matrix and ensures the connection with the 16 digit chains.

The memory employs a destructive read system, random access, and linear word selection. A simulator controls the following functions.

(A) The choice of the number of cycles and of the triggering mode. In exterior mode, the memory can work either in single-shot manner, the work cycles being triggered one by one, or in recurrent manner at a frequency determined by an external pulse generator. In interior mode, an incorporated monostable multivibrator, triggered by a manual control, determines the number of cycles equal to 10^n , where $n = 1, 2, 3, 4, 5$, or 6 , depending on the position of a switch.

(B) The manual choice of address and displaying of the chosen address in binary code.

(C) The display of the state of the output registers.

(D) The manual choice and the display of the state of the input registers.

(E) The choice of the working mode. Two modes are possible: (A) the write mode, which includes setting the address registers, resetting the output registers, destructive reading of the information contained at the chosen address and setting the output registers corresponding to this information, and writing at the address chosen new information that corresponds to the state of the input registers; (B) the read mode, which includes all the preceding operations except the last one. This is replaced by the rewriting of the contents of the output registers at the address chosen.

The simulator enables very-complete tests to be made of the operation of the memory, including tests of the creep effect under the worst disturbance conditions. The number of disturbing digit pulses and of disturbing pulses of the neighboring word can either be fixed at 10^n or can equal, in recurrent operation, the product of the repetition frequency of the external generator and of the time of the test duration (for example,

300 million per minute). The code to be written in the memory and the disturbing code can be of any kind.

Figure 4 includes different circuits associated with the memory. These are described in following sections.

5. Circuits

5.1 CLOCK

The clock of the memory is aperiodic. When it receives a triggering pulse, it supplies 4 pulses that synchronize the operation of the memory:

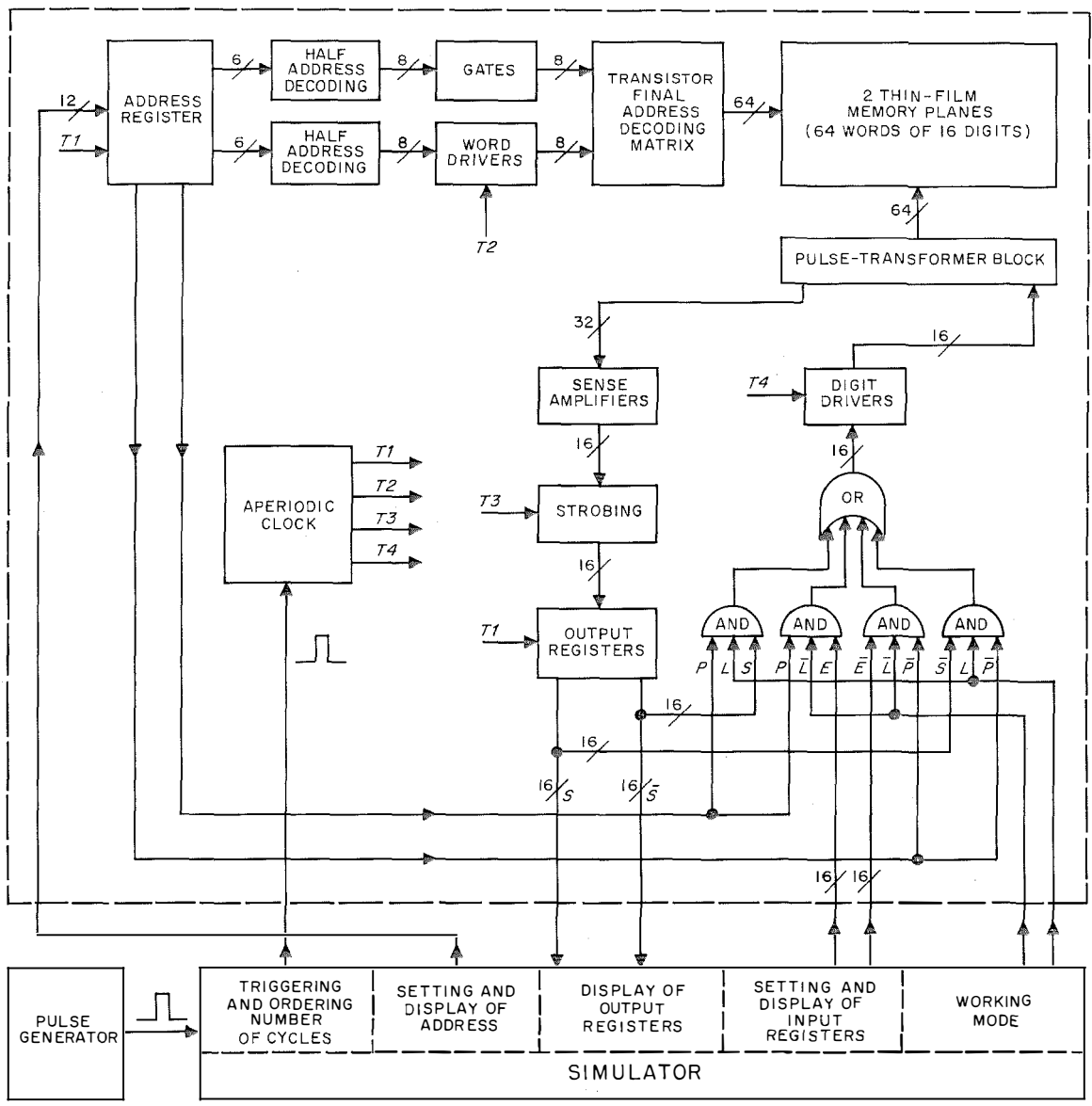

Figure 4—Organization of the memory.

Memory for Test and Evaluation of Thin Films

$T1$ sets the address registers and resets the output registers; $T2$ determines the position in the cycle and the duration of the drive (word) current; $T3$ strobes the output of the sense amplifier; and $T4$ determines the position and duration of the information (digit) currents.

The delays and the pulse durations are determined with very-good precision by measured lengths of coaxial cable.

5.2 WORD CIRCUIT

The diode-transistor-logic flip-flops constitute the address registers.

The diode partial decoding of address supplies 2 groups of 8 outputs for driving the 8 word drivers and the 8 gates. The transistor final decoding matrix has 1 transistor per word; its

collector is connected to the word line, its emitter to a word driver through a resistor that limits the word current, and its base to a gate transistor.

Figure 5 shows the memory. Starting from the left are the 8 driver transistors, the decoding matrix of 8-by-8 transistors, and the mounting device for the 2 memory planes.

The decoding matrix, as well as the terminal stages of the word generators, are placed very close to the memory planes to limit the inductance of the paths of the word currents.

5.3 DIGIT CHAIN

Each digit chain includes a sense amplifier, strobe, output register, logic, and digit driver.

Figure 6 shows a double-face printed circuit

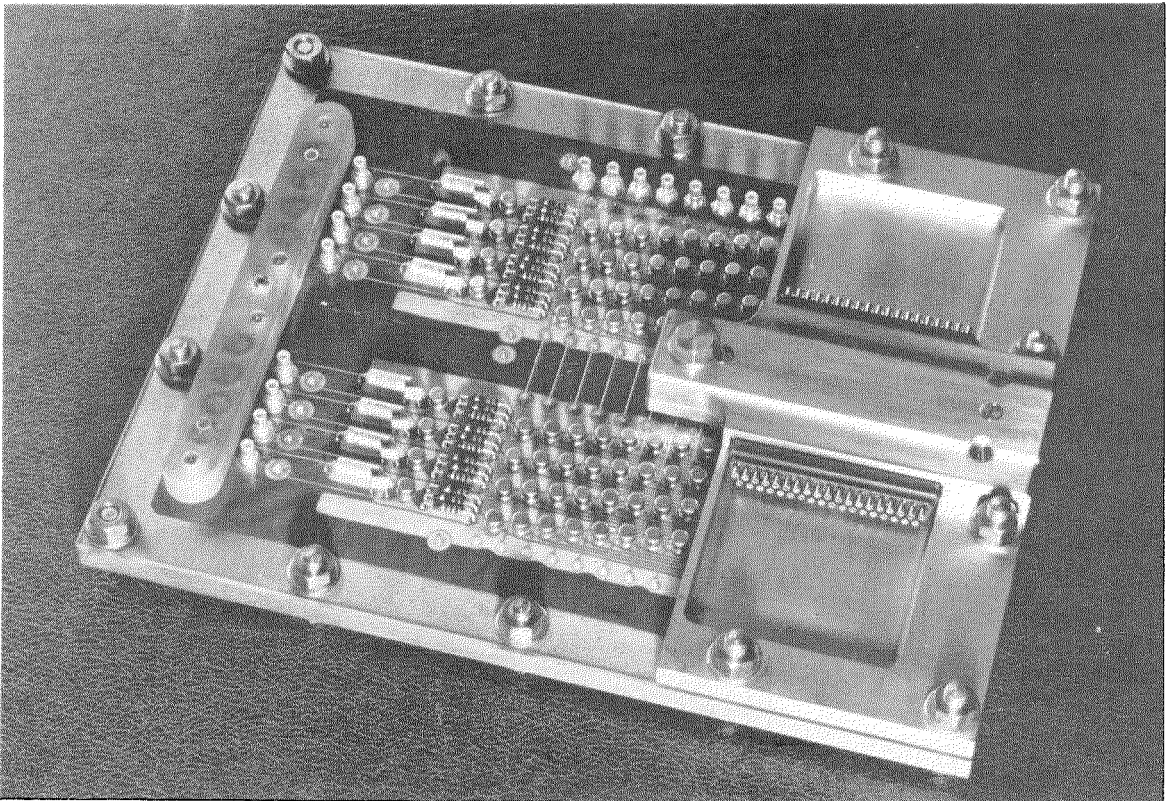

Figure 5—Memory mounting that includes transistor decoding matrix and drivers.

that contains two complete digit chains. All the elements are placed on one side, the conductive coating of which is used for the common ground. The other face is etched to provide for all the interconnections.

5.3.1 Sense Amplifier

Thanks to the very-good rejection of stray signals, the sense amplifier is relatively simple. Each has 6 transistors: a differential stage is followed by 3 linear amplifier stages with series feedback (resistance-capacitance elements in the emitter circuit) and by a common-collector output stage. A clipping system with diodes, plus a nonlinear characteristic of gain versus amplitude, suppress signals of incorrect polarity and also limit those of correct polarity if their amplitudes are excessive.

5.3.2 Strobing

In thin-film memories without stray-signal compensation, it is necessary to select the signal in time (strobing) at low level, often by means of a very-narrow strobing gate. This leads to delicate adjustments of critical circuits. In the memory described here, the sampling was replaced by an AND condition with transistors, which is done at the output of the sense amplifier. The transistor that drives the output register receives the amplifier output signal on its base and the strobing gate on its emitter. The time position and the width of the latter are not critical.

5.3.3 Output Register

This register comprises a diode-transistor-logic flip-flop. Resetting it at the beginning of each

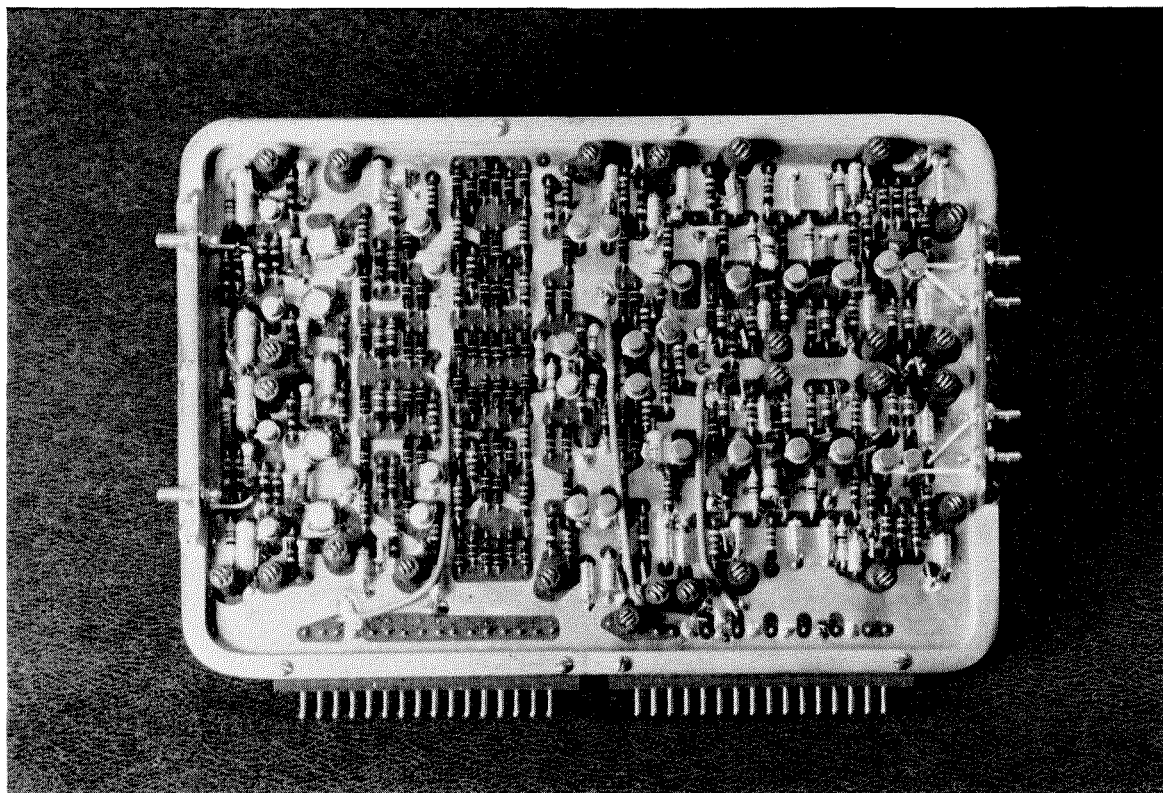

Figure 6—Two complete digit chains.

cycle permits single-polarity signals to be used in the sense amplifier.

5.3.4 Logic

The compensation system for information stray signals introduces a polarity inversion of output signals of one plane with respect to those of the other plane for the same polarity of information pulses. This must be taken into account by introducing a condition of parity P , determined by the state of the slowest address register, either at writing or at reading. The same logic stage is used to introduce the working mode, which gives the condition

$$I = SPL \vee \bar{S}\bar{P}L \vee EP\bar{L} \vee \bar{E}\bar{P}\bar{L}$$

where

S is the state of the output register

E is the state of the input register

L is the read order

\bar{L} is the write order

I is the information polarity.

5.3.5 Digit Driver

The bipolar digit driver has two output stages (one for each polarity) driven by two ampli-

fier stages through pulse transformers. This permits elimination of the supplementary logic condition \bar{I} , the same logic transistor opening a transistor AND gate and closing another AND gate in diode-transistor logic, or vice versa.

6. Results

Figure 7 presents the complete model of the memory including all the access elements (in the center) as well as the simulator (at right).

All the associated circuits use silicon planar epitaxial transistors. With few exceptions, all the transistors are of the $2N709$ type (logic and amplification) or $2N3013$ type (high current).

The word current has an amplitude of 400 milliamperes and its rise time is less than 20 nanoseconds. The amplitude of the digit current is 2×75 milliamperes and the rise time is 20 nanoseconds. The output signal is ≥ 1 millivolt.

The sense amplifier has a gain of 74 decibels, its delay is < 8 nanoseconds, the rise time at the output is 10 nanoseconds, and the recovery time after the digit stray signal is < 30 nanoseconds.

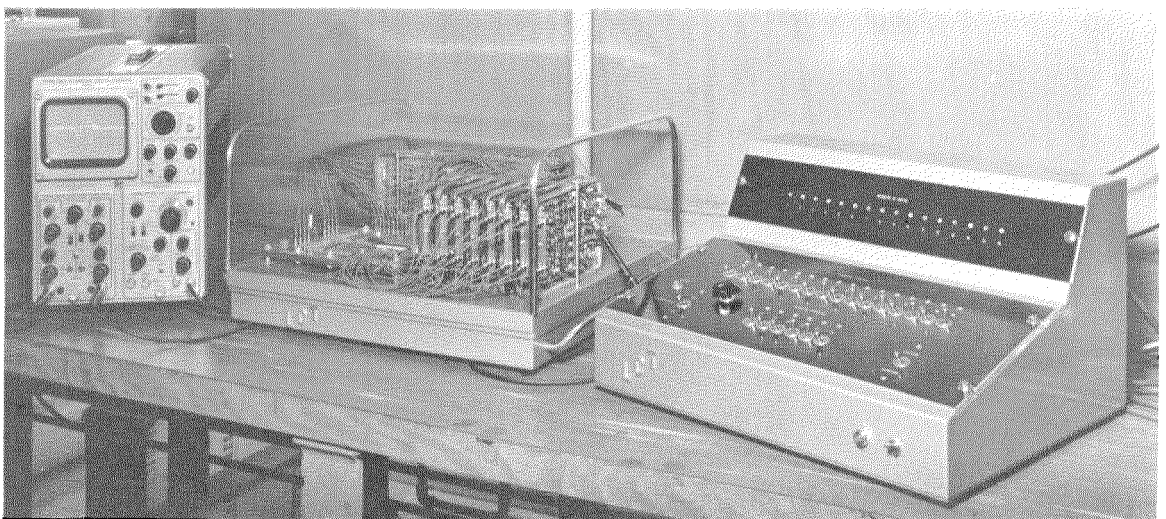

Figure 7—Complete memory and simulator in working order.

Oscillograms of the signals on the second active stage of the sense amplifier and at the output of the output register in state 1 (Figure 8A) and in state 0 (Figure 8B), show the performances of the memory. They enable the ratio of the useful signal to the stray signal as well as the working speed of the memory to be evaluated.

The access time (total read time) is the time between the beginning of the cycle—marked by the reset of the output register—and the moment the register is set. It includes the complete address decoding, the duration of reading, the delay of the sense amplifier and the strobing, and the setting of the register. It is equal to 60 nanoseconds.

The oscillograms were taken for recurrent operation at a frequency of 5 megahertz. The signals in the sense amplifier show that the minimum cycle time (the minimum duration between the beginnings of two consecutive

read-write cycles) can be less than 150 nanoseconds, which has been experimentally verified.

Particular care has been given to the problem of reliability and especially to the creep effect. Systematic tests, made a great number of times at different addresses, have included the following operations.

(A) Writing a code consisting of a sequence of 0's, a sequence of 1's, alternate 0's and 1's, or any random code, at address j in single-shot manner.

(B) Writing the complementary code at the address $j - 1$ and at the address $j + 1$ between 1 million and 5 million times.

(C) Reading the contents at address j in single-shot manner, or 1 million times (with rewrite).

Operation (B) has been made also in recurrent mode totaling some 10^{10} disturbing pulses (simultaneous disturbance of the digits and of the neighboring word). No failure has been found.

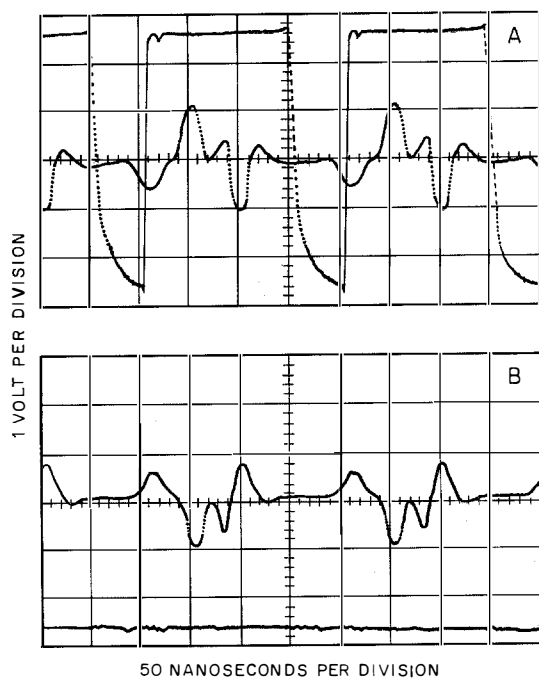

Figure 8—Memory output signals and output-register signals in state 1 (A) and in state 0 (B).

7. Conclusions

The reliability test made by means of the memory described was extremely severe. The important result of this study is that even a continuous magnetic film that is relatively thick (1500 angstrom units) can be entirely insensitive to the creep effect if it has suitable characteristics (inverted film, uniform values of H_K and H_C , and small angles of dispersion α_{90} and skew β), and if the access conductors are properly dimensioned.

Moreover, good compensation of the stray signals permits their level to be lowered to the level of the useful signals to attain very-short cycle times. It is reasonable to envisage 100 and 200 nanoseconds, respectively, for memories of 10^4 and 10^5 bits.

The model described here was completed in 1964. More-recent realizations use thin magnetic films deposited on a thinner glass substrate (90 microns) and on a metal substrate.

They serve to build a memory with a larger capacity ($\sim 10^5$ bits) and to decrease cost by reducing the price of the associated electronics. They also permit reduction in access currents, reduce the series inductance of the access conductors and the amplitude of the stray signals, increase the output signal (other parameters being equal), and increase the density of information.

At the present time, magnetic thin films are particularly well suited for the construction of ultra-fast memories (cycle times from 100 to 200 nanoseconds) of a moderate capacity (10^4 bits) with linear word selection.

Now that we know how to prepare the films and how to eliminate the stray signals, the continuing high price of the associated circuits is the only factor that seriously limits their use in slower memories (cycle times > 300 nanoseconds) of a larger capacity ($\geq 10^5$ bits). The remedy can come from the very-rapid decrease in the price of semiconductors (transistors and diodes) that is now occurring, from the optimum dimensioning of the matrix (multiple words, et cetera), and from the use of integrated circuits manufactured in very-large quantities [8] (decoding matrix, sense amplifier, et cetera), or perhaps from a coincident selection system that enables the construction of 3-dimensional memories.

8. Acknowledgments

This paper presents the work of a team of engineers and technicians. I wish to thank all my colleagues who have contributed to this study.

J. M. Tyszka was born in Lodz, Poland, on 23 May 1931. He received a bachelor of science degree in electrical engineering in 1954 and a master of science degree in 1957 from Politechnika Warszawska, where he also served as a faculty assistant. In 1962, he received his Doc-

9. References

1. M. S. Blois, "Preparation of Thin Films and Their Properties," *Journal of Applied Physics*, volume 26, number 8, pages 975-980; August 1955.
2. J. I. Raffel, T. S. Crowther, A. H. Anderson, and T. O. Herndon, "Magnetic Film Memory Design," *Proceedings of the I.R.E.*, volume 49, number 1, pages 155-164; January 1961.
3. A. V. Pohm and E. N. Mitchell, "Magnetic Film Memories, A Survey," *IRE Transactions on Electronic Computers*, volume EC-9, number 3, pages 308-314; September 1960.
4. E. M. Bradley, "Properties of Magnetic Films for Memory Systems," *Journal of Applied Physics Supplement*, volume 33, number 3, pages 1051-1057; March 1962.
5. A. Judeinstein and J. M. Tyszka, French patent PV 953 663.
6. A. Judeinstein, "Measurement of Magnetic Properties of Thin Films," *Electrical Communication*, volume 41, number 1, pages 65-71; 1966.
7. J. M. Tyszka, "Dynamic Measurements of Magnetic Thin Films," *Electrical Communication*, volume 41, number 2, pages 161-166; 1966.
8. A. J. Khambata and R. C. Green, "Memory Circuits—from Conventional Component to Full Integration," *Proceedings of the I.E.E.E.*, volume 52, pages 1703-1709; December 1964.

torate of Engineering from the Faculty of Sciences of the University of Paris.

In 1960, Dr. Tyszka joined Laboratoire Central de Télécommunications, where he has worked on tunnel-diode memories, pulse circuits in the nanosecond region, and magnetic thin films.

Data Transmission—Current Trends and Future Prospects*

J. W. HALINA

ITT Europe Inc.; Brussels, Belgium

1. Introduction

A broad and significant spectrum of changes is taking place in which we, as members of the engineering community, share a great responsibility. These changes are so extensive and they are occurring at such a rapid rate that one might be tempted to call them a revolution if that word were a less-inept term. They do not constitute a full revolution in the sense of turning everything upside down and a returning to the point of departure in what might be described as a disturbing but otherwise futile turmoil. Rather, they more-closely resemble an evolution in high gear—a forced march—that has had marked impact on both communications and computation industries as well as on many other fields.

I suppose that it would not be impossible to isolate the subject of data communications in a technically antiseptic way and confine this discussion strictly to decibels, bits, coding, error correction, and the like. In so doing, we would be apt to discover a tree and almost completely miss the forest. To gain a true perspective for the subject, we need to step some distance back for a more-objective look at our century and where we fit in its clockwork of change. Actually, there seem to be two periods in this 100-year span between which there are a number of resemblances, both occurring within the first (1900–1910) and middle (1945–1955) decades of the scale.

In the first of these decades we had the internal-combustion engine, automobile, mass produc-

tion, and telephone. Both the automobile and the telephone grew spectacularly, expanding at a compound rate of approximately 40 percent per year and doubling every two years. This growth wave, whose crest did not break until the stock market crash and the depression, endured for a quarter of a century. A similar machine/communications pair were the steam engine and the telegraph a century earlier.

In the mid-decade of the twentieth century, we encountered another familiar combination in the jet-craft, rocket, computer, and data communications. These developments rival in scope, impact, and endurance the steam engine/telegraph and automobile/mass production/telephone combinations of the 18th and 19th centuries. It is doubtful that the crest of this new technological wave will break much before 1975.

The growth dynamics of some of the key parameters of our environment in the 1950–1975 quarter century offer an equally, if not more, striking view of the prospects that confront us. A few of these have been plotted in Figure 1 for comparison. The lowest and flattest of these curves is that of population growth at a world mean of about 1.8 percent per annum, a compound rate that doubles the population every 40 years. The second curve represents the mean growth rate (7.5 percent) of gross

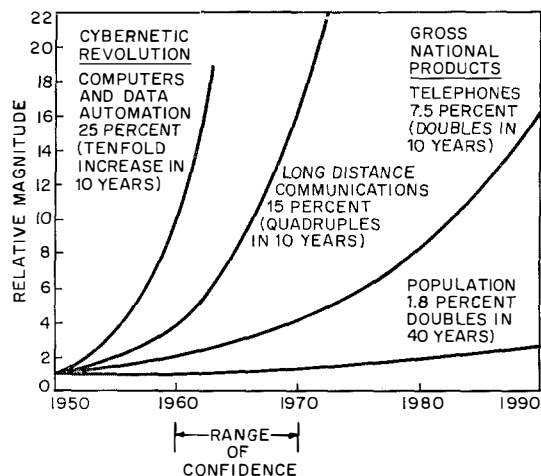

Figure 1—Growth dynamics.

* This paper is based on two talks given by the author on the subject of data transmission. The first of these, "Data Communications: Their Future Prospects," was delivered at the Winter Study Group on Data Communications Systems of the American Institute of Electrical Engineers in New York on 25 February 1963. The second was entitled "World Data Transmission" and was delivered at the American University Institute on Data Transmission in Washington on 4 March 1963. This transcript has been prepared in response to the large number of requests for copies received at ITT Communication Systems, with which the author was then associated. He has since been transferred to ITT Europe.

national products in the developed nations of the world and of telephones in the United States. In general, specific industrial-growth-rate factors, which are in the same league as that of the gross national products, are unspectacular but healthy phenomena and constitute a sound return on investment.

There are two other growth trends that are distinctly steeper than the normal and sober 7.5 percent. The first of these is the expansion of long-distance communications, in particular transatlantic traffic, at a rate of 15 percent per year, or a quadrupling every 10 years. This trend has been sustained for over 10 years and seems to be well established. The steepest curve, which represents the computation and data-automation field, is in the phenomenal or "boy wonder" class and represents a growth rate of the order of 15 to 25 percent per year, or a ten-fold increase every 10 years. This is our cybernetic revolution.

What speculations can we make concerning the motivating factors behind these growth trends? The 7.5-percent growth trend in conventional telephony correlates very closely with improvements in general standards of living and gross national products. The 15-percent growth curve in intercontinental telephone traffic is clear evidence of a shrinking planet. It received its great impetus from the military interdependence between North Atlantic nations through World War 2, an interdependence that has endured and grown steadily in both the military and commercial sectors. Indeed, a number of other technological developments that outpaced communications development created a backlog of communications demand that is still unsatisfied.

Significantly, marine and airborne transportation has been conquering the intercontinental ocean spans at a consistently faster rate than communications. Almost any survey will uncover substantially more persons who have made a transoceanic trip than have made a transoceanic telephone call. There are still many places in the world today to which an airmail

special delivery letter can make about as good time as a telegram. The intercontinental communications growth rate is thus in part a natural annual accretion and in part a matter of catching up on the deficiencies of the past.

The most-interesting and probably most-consequential set of motivating factors are those relating to the 25-percent growth rate. It might be aptly called the "information explosion" or perhaps more properly the "paper explosion," a phenomenon felt in every home, engineering laboratory, doctor's office, accounting department, and mailbox. In most of the sciences, the rate of output of new information in the form of research reports, technical journals, books, internal memoranda, product announcements, and specifications has far outstripped the capacity of their members to ingest and absorb. No engineer, doctor, or physicist is able, and probably very few would even try, to read more than a small fraction of the new literature pertaining to his field. The modern demands of fiscal management and accounting have long exceeded the capacity of the bookkeeper in Charles Dickens' day. The management of research, manufacturing, transportation, government, and almost every other type of enterprise has become in some part dependent on storing, processing, and retrieving mountains of information.

This explosion must explain the frequently made prediction that sometime between 1970 and 1980 there will be as many digital messages as voice messages flowing through the circuits of the North American telephone network. Since this \$30-billion plant is almost completely occupied with the transmission of voice telephony today, the materialization of this prediction implies an unbelievable rate of increase in digital or data traffic. All of which, of course, raises the obvious question: Where are all these digits to come from and how will they be generated? There are about 70 million telephones on the North American continent today and by 1975 there will be approximately 150 million. If at that time digital traffic should

equal that of voice communication, can we expect the appearance of 100 million digital generators comparable to telephones?

Before we even hazard answers to these questions, it may be helpful and enlightening to review briefly the history of data transmission over the past 10 years.

2. The 1951–1961 Decade in Data Transmission

It is always difficult and risky to fix a clear-cut date for the beginning of anything. If, however, we had to name some year to mark the beginning of the age of “datamation,” 1951 would probably be the most-likely candidate. This was the year of the Charles Committee report on North American Air Defense [1] and the conception of the Semi-Automatic Ground Environment Complex, more-familiarly known as Sage.

In a highly oversimplified way, the Committee suggested that the defense of North America against air attack was a problem of a vastly different scale than that faced by General Custer, who from his hilltop command post could maintain a reasonably clear view of the operation. Any engagement potentially involving thousands of aircraft, friendly and hostile, deployed over a vast continental area, would involve an information problem that obviously is not within the scope of couriers, voice telephony, Morse telegraphy, handwritten messages, and all that complex but nevertheless impotent paraphernalia of contemporary communications.

How else, then, could the information volcano that would erupt under a mass attack be controlled? For one thing, it would have to be handled with the aid of electronic computers and on the basis that radar sensors could supply their information to computational centers where it would be digested and displayed. From these data, appropriate control information could then be derived and forwarded to fighter aircraft and ground-to-air missiles. Un-

der such a scheme, the capabilities of a computer for filing, processing, and retrieving information in large quantities and with great speed would become the central factor in the whole concept.

The Sage concept caught on quickly. If computers and data telecommunications could help solve a continental air-defense problem, could they not be applied with equal success in another “air battle”—that of airline reservations?

To survive, the airline industry could not run things the way the railroads did. An air traveler could hardly be expected to stand at a “railroad-ticket window” while the clerk took hours to consult tables, reserve sleeper accommodations, and write long multifold tickets. It had to adopt an automatic computer/data-transmission system that could confirm the availability of a very-complex itinerary within seconds. Since then, several major corporations have adapted this formula to centralized accounting for their complexes of branches and subsidiaries—among them, a number of banking institutions [2].

In the decade between 1951 and 1961, the computer graduated from the novelty phase to one of increasing acceptance. Indeed, the computer industry was moving faster than its companion, the data-transmission industry—a situation somewhat reminiscent of the manner in which air travel outpaced telephone communication across the oceans. A graphic example of this anomaly is offered by the bank with which I do business. The management has had a computer installed for its accounting work for a year. That machine can update my bank balance or that of any other account within a split second after it has received the amount of the last deposit or withdrawal. However, if one of the bank’s clients comes in to cash a personal check in excess of some established amount, the rules require that the clerk check on the status of the account. The clerk then walks to a telephone, dials the accounting department, and, while the client stands shifting his weight from one foot to the other, takes 5 to 15 minutes to find out what the computer says the balance

is! The reason he is unable to put the check into some kind of a reader that could electrically scan it, transmit the information to the computer, determine whether there is a sufficient balance, and answer “Yes” or “No” is that such a device and the associated transmission service are too costly. Here, as in the examples previously cited, data transmission has become the fly in the ointment of progress.

How and why is there a data-transmission problem? If it is a present block to the rapid and continued expansion of automated information handling, we should try to understand the contributory reasons.

3. Data Transmission

As modulation techniques go, that chosen for Sage—a vestigial-sideband amplitude-modulation system—is probably considered primitive by today’s standards. The three components of the input signal, namely, synchronizing, timing, and data, were discriminated by the various modulation amplitudes assigned to them. Two speeds were selected, 1300 bits per second for general Sage data-transmission services and 1600 bits per second for radar sensor terminals. The scheme has worked reasonably well from its inception.

The Charles report was published in 1951, and Shannon’s “Mathematical Theory of Communication” appeared in the July and October, 1948, quarterly issues of the *Bell System Technical Journal*. Shannon’s work had scarcely had time to make its impact on Sage. Shannon’s influence, both for better and worse, became evident later in the mid-fifties.

I rank the work of Shannon together with that of his teacher and mentor, Wiener, among the major events in contemporary man’s intellectual evolution: with Euclid, Kepler, Newton, Darwin, and Einstein. Its significance in and out of engineering has yet to be fully assayed. Like most theories, however, Shannon’s have been incredibly misunderstood or misapplied.

In the extremely narrow application to data transmission, the effect of Shannon’s research is probably most simply traced to an equation more frequently quoted by engineers than the fifth amendment by witnesses before Congressional committees. The equation is

$$C = W \log_2 P/N, \text{ approximately, if } P/N \gg 1.$$

In a very-naive interpretation, the equation rationalizes capacity in the following way: If the scale of a measuring rule has graduation marks that are rather fuzzy and of a width V_n , then we can measure a dimension V_p into V_p/V_n intervals.

If a signal is represented by an electrical power P , and the noise present in the signal has a power N , then P can be taken as a dimension to be measured and N as the width of the measuring scale. Since, however, power is a time integral, a measuring or detection device that works instantaneously can operate only on the voltage or current component of the signal; that is, on the square root of the signal and noise powers. Accordingly, the number of levels that can be discriminated in a signal of power P corrupted by noise of power N is $(P/N)^{1/2}$.

The number of bits of information in such a discrimination is a logarithm of this number to the base 2. The frequency with which such discriminations can be effected in a channel of bandwidth W is, by Fourier’s sampling theorem, $2W$. Accordingly, the capacity of a channel of bandwidth W and signal-to-noise power P/N is

$$C = 2W \log_2 (P/N)^{1/2} \text{ or } W \log_2 (P/N).$$

If we are long on Shannon and short on fact about the channel, the following fallacious argument can be made very quickly.

The telephone engineer says that his toll-quality channel is 4 kilohertz wide and that its signal-to-noise (root-mean-square) ratio is about 42 decibels. If the peak-to-root-mean-square ratio of noise is 12 decibels (it is for thermal, white, or otherwise “well-behaved” noise), then we ought to be able to discriminate $\frac{42 - 12}{6} = 5$

bits per second of information in the amplitude coordinate of the channel information space. That is to say, for a toll-quality telephone channel

$$\log_2 (P/N)^{1/2} = \frac{P/N - 12}{6} = \frac{42 - 12}{6} = 5.$$

Since the W dimension is 4000 hertz, the capacity of this channel is

$$C = (2) \cdot (4000) \cdot (5) = 40 \text{ kilobits per second.}$$

Clearly, therefore, it would be possible to do better than the 1300 and 1600 bits per second used for Sage. The solution was to find an ingeniously optimum coding, correcting, and signal design scheme.

The race was on. Data modems were invented almost as rapidly as publishers could print papers. Each invention was given an acronym of some kind for its name, and papers began to appear showing how closely device A resembled the Shannon ideal as compared with someone else's brand X . Their names are a part of the 1950–1960 data-transmission lore: *SEBIT, KINEPLEX, CTDS, PHASE MULTILOCK, DATATRAN*, et cetera. The modulation schemes included amplitude modulation (single sideband, vestigial sideband, and suppressed carrier), phase shift (2 phase, 4 phase, and 8 phase), frequency shift (2 fre-

quency, 4 frequency, and 8 frequency). Besides the speeds of Sage (1300 and 1600), we had 600, 750, 1000, 2000, 4800, and 5400 bits per second. Recently there have been one or two claims for 18 000. In this period we witnessed a deluge of papers on error detection and correction ranging from the readable to the completely abstruse.

After a decade of furious and quite-costly one-upmanship, we are just about where we had been for about 30 years. Frequency-division-multiplex telegraph systems placing 12 to 18 telegraph channels each at 100 words per minute on a telephone channel accommodated an effective 1200 to 1800 bits per second. Reasonably errorfree data transmission using the best of current data modems on run-of-the-mill telephone channels can provide somewhere between 1200 and 2400 bits per second. "Plus ça change, plus c'est la même chose."

What happened in this 10-year period? Why did we spend 10 years figuratively racing our motors on the runway without taking off?

I think it was a consequence of two groups of engineers (whom I will call the radio engineer and the telephone engineer) not communicating too well with each other and, for that matter, looking at each other with something less than respect and enthusiasm. The radio engineers rallied around the Institute of Radio Engineers, while the telephone and power engineers supported the American Institute of Electrical Engineers. The radio engineers were the traditional radicals of the electrical-engineering profession and the power and telephone engineers the traditional conservatives—with good historic reason for both outlooks.

The radio engineer is the designer of the independent device, the television and radio set, the radar set, the single link point-to-point communication device, the high-fidelity set. His most-complex system configuration is the concentric network of Figure 2. If the device at the hub of the system is a television transmitter and the terminals are domestic television receivers, and if the reliability of any one television

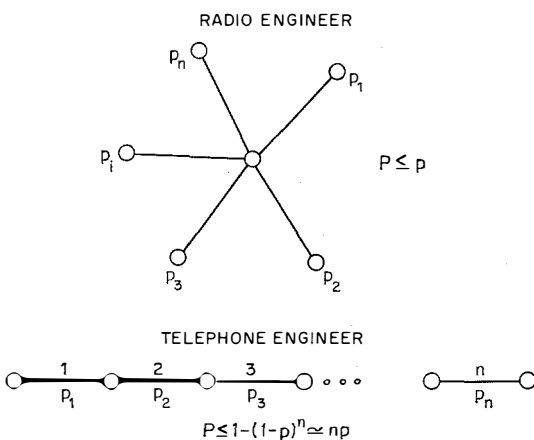

Figure 2—The tandem and parallel worlds of the telephone and radio engineers.

Data Transmission—Current Trends and Prospects

receiver is, for example, 0.9 and the reliability of the broadcast transmitter is 0.99, the reliability of the whole system is about 0.9. Its effective reliability is its reliability from the point of view of a user. Certainly, the failure of a television set in the middle of a boxing match is not going to cause a flood of telephone calls to the broadcasting station or to the Federal Communications Commission.

The telephone engineer is essentially a designer of tandem systems (see Figure 2). A circuit from San Francisco to New York spans some 3000 miles (4800 kilometers) and must cope with an attenuation equivalent to about 3 decibels per mile (1.9 decibels per kilometer) for a total of about 10 000 decibels. This circuit requires a numerical gain of 10 to the power of 1000, or a figure 1 with 1000 zeros after it. There may be as many as 300 repeaters in this chain.

Now consider, if you will, a high-fidelity set that is assumed to be operating 99 percent of the time and is down 0.1 decibel at 10 000 hertz from its gain at 1000 hertz; then visualize 300 of these strung in tandem to form a chain, and you will be able to appreciate the dichotomy that exists between telephone and radio engineers. What each calls reliability and high fidelity are, in fact, quantitative concepts that are orders of magnitudes apart. Under these circumstances, the high-fidelity chain would not only be down 30 decibels at 10 000 hertz but would be working only 70 percent of the time.

Other differences also characterize the two. The radio engineer pursues the spectacular, and if it means putting a handful more transistors, diodes, transformers, and resistors into the equipment, he is not too chagrined. He can use temperamental devices, high-impedance interfaces, and trigger-sharp adjustments that must

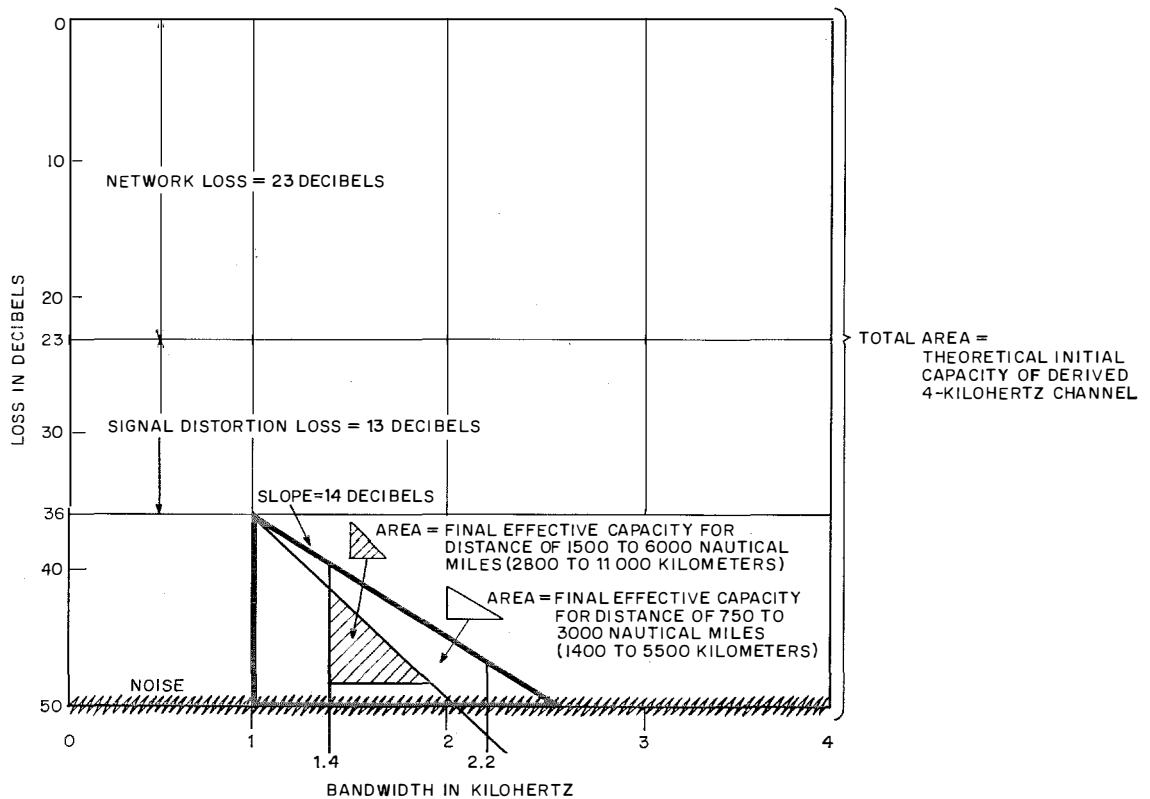

Figure 3—Information capacity of a telephone channel.

be corrected every few hours or few days. To the telephone engineer every dynamic or adjustable device is a menace. His long tandem connections magnify, to the point of intolerance, imperfections that are not easily observable when a single device is under test.

The telephone channel is, paradoxically, a product of the telephone engineer's design and of his problems. In the first place it was designed for voice. Its principal characteristics were formulated in the first quarter of this century, long before the whirlwind computer.

What is voice and what can it take in the way of degradation in transmission? We know that it is a very-redundant signal, but we do not know enough about this redundancy to code voice into anything like the few hundred bits indicated. However, with certain reservations we can make the following statements: Voice occupies a spectrum between 50 and 7500 hertz. Of this we can transmit the band between 450 and 1800 hertz with few or no complaints from the listener. Although human speech has a dynamic range of about 25 decibels, we can infinitely clip it and still get intelligible transmission. We can deliver it to a user at signal-to-noise power ratios of 15 decibels before he rebels. The threshold of phase-distortion awareness is about 10 milliseconds and 20 milliseconds will pass. In short, the voice-signal transmission and detection system of the human being is robust enough to allow major mutilation in conveyance. And since the rule of all commerce is to produce an acceptable product at the lowest possible cost, the toll-quality channel does indeed mutilate in the interests of a universal low cost and (as it turns out) an unusually effective service. The result, however, is far from the 40-kilobit-per-second capacity. Indeed, by the time the telephone channel has traveled some 3000 miles (4800 kilometers), its effective capacity is somewhere between $\frac{1}{16}$ and $\frac{1}{32}$ of the transmission "space" with which it starts [3]. The vertical ordinate is contracted by losses and noise accumulations and the horizontal coordinate by phase and

slope distortions. The resultant effective capacity has the appearance of Figure 3.

By far the major part of this degradation takes place in the single-sideband channel modem of the telephone multiplex system and in the repeated interconnections that must take place at the demodulated signal level.

The channel modem of the telephone plant is the final device in a mechanism that subdivides the wide bands of the telephone transmission facility into the channels that the ultimate user requires and is willing to pay for. The next-wider band from which this channel is derived is the basic group, a 48-kilohertz band transferred in frequency by single-sideband modulation to the spectrum slot of 60 to 108 kilohertz. This basic-group band, used directly, has been demonstrated to be capable of carrying data at a rate of about 40 kilobits per second. Since 2 of the channels in this band are degraded by the effects of the group filters, there are 10 good voice channels in it. Thus the effective capacity of the group is about 4 kilobits per second per voice channel.

Starting with this information as a datum point, we might take a superficial but enlightening look at the economics of our contemporary attacks on data transmission over the voice channel as illustrated in Figure 4.

If we begin with the previously noted effective capacity of 4 kilobits per second per channel possible before the appearance of the channel modem, we will find that the cost of building such a channel by the wide-band methods of today is approximately \$35 per channel-mile (\$20 per channel-kilometer) or \$50 000 for a 1500-mile (2400-kilometer) circuit. The cost of the channel modem is about \$1000 and about \$5000 worth of them are required in a 1500-mile circuit. Their effect on the capacity of the system, however, is quite out of proportion to their cost. These devices and the baseband interconnections at the intervening points in the circuit reduce the effective capacity of the channel to between 1200 and 2000 bits per second. In our present practice, we add a data modem

at a cost ranging from \$5000 to \$10 000. This modem in part translates the on-off direct-current signal of the data source to the frequency spectrum of the voice channel. Its more-expensive part is occupied with parallel-to-serial translations and various other ingenuities to cope with phase distortions that the single-sideband modem introduces into the circuit. By this means we may succeed in raising the transmission rate to 4800 bits per second. In the process however, the error rate has been pushed up from about 1 in 10^6 (obtained by working at 1200 bits per second) to perhaps 1 in 10^4 as a result of working at 4800 bits per second. To correct this effect, we add as much as 100-percent redundancy into the signal with an error detector-corrector costing anywhere from \$10 000 to \$20 000. The resultant rate is about 2400 errorfree bits per second.

What happened to the cost in this “up-down” process? It started with a \$50 000 channel to which we needed to add about a \$10 000 data modem to get 40 kilobits per second of data-transmission capacity at \$1.50 per bit per second. However, in our resultant system we have:

10 × 5 or 6 single-sideband channel modems at about \$1000 each	\$ 50 000
10 data modems at, say, \$7500 each	75 000
10 error correctors at, say, \$15 000 each	150 000
Transmission facility	50 000
Total	\$325 000

We obtain 10 channels of 2400 bits per second or 24 000 bits per second at about \$13.00 per bit per second.

The “up-down” attack, as it must be obvious to any enterprising observer, can be pushed to any distance. For example, by the addition of a \$75 000 data modem after the telephone channel modem, one might push the speed to 18 000 bits per second (with a considerably higher error rate). Then, by adding a more-sophisticated error corrector costing about \$100 000, the end useful errorfree rate may be 4800 bits per second. The result of this maneuver would

be to raise the total investment to \$1 800 000 for a capacity of 4800 bits per second or an investment of \$1 800 000/4800 or \$360 per bit per second.

This, in essence, has been our data-transmission strategy. It provides for good information-theory exercises, technical sophistication, and interesting reading. But, more important economically, it takes us ever farther from the \$1.50 per bit per second at which we should be able to offer transmission to the age of datamation.

Nevertheless, this has been our 10-year history—a record characterized to a great extent by the creation of a jungle of codes, speeds, and languages. The situation has reached the point where it is impossible for two data systems to “talk” to each other because of differences in modulation, speed, code, and format.

Looking back at the 1950–1960 decade of the data revolution or evolution, we have little cause for self-praise or gratification. If we had deliberately set out in 1951 to devise a program that would strangle the datamation infant, we could hardly have done a better job.

It would not be fair, however, to end this story with a thunderclap of condemnation or in the sanctimony of hindsight. We entered the decade without experience. Unlike the telephone engineer, we did not have nature to prestandardize the signal as in the case of voice. The telephone common carriers did not enthusiastically join the fray with either risk capital or advice. They chose to stand aloof and to observe what would happen. The radio engineer, on the other hand, had to explore the technological jungle on his own.

It would be fair to say, however, that the experimental data are now in. We would have great justificatory difficulty indeed if, in 1971, we did not learn anything and are still playing the diversity game. If we are, the hoped-for data revolution will continue to run its chaotic course, with the data age, like the pot of gold at the end of the rainbow, always receding.

On a more-constructive note, let us briefly survey the gains we have made and the problems we need to surmount in the next few years.

4. Some Developments in Transmission

In the decade in which the datamen were striving intensely and, as we have seen, with some profusion to derive more bits out of the telephone channel, a spectrum of developments took place in the teletransmission field, developments that will probably reach their denouement by 1970.

Transmission plant has been traditionally categorized in telephony by distance. Local or loop transmission includes the facilities that span the distance of a few hundred feet to a few miles between the subscriber's telephone set and the local exchange. Tributary transmission encompasses the spans from 15 to 150 miles (24 to 240 kilometers) between local exchanges, and between local exchanges and regional tandem switching centers. Medium-haul transmission encompasses the spans from 150 to 1500 miles (240 to 2400 kilometers) between regional switching centers. In the United States, the latter facilities are sometimes referred to as long lines. Finally, the long-haul category includes the spans from perhaps 1000 to 5000 miles (1600 to 8000 kilometers) that provide the intercontinental bridges. The abscissa of Figure 5 has been graduated in miles as well as pictorially in terms of these four major and overlapping categories of telephone transmission plant. The ordinate is graduated in terms of channel capacity.

In the decades preceding the 1950-1960 decade, the mainstays in the various categories of transmission plant were the following.

(A) In the local or loop category, we had the twisted-pair loaded cable; capacity was one voice channel per pair with 12 to about 1000 pairs per cable sheath. Because of the interwire capacitance, the twisted pair has a transmission loss characteristic that increases by a rate ap-

proaching 6 decibels per octave above about 1 kilohertz. It is necessary to flatten this characteristic by adding series inductance in such a way that, in combination with the interwire capacitance, the line becomes a 4-kilohertz low-pass filter. Loading coils are added at intervals of approximately 1 mile (1.6 kilometers) to

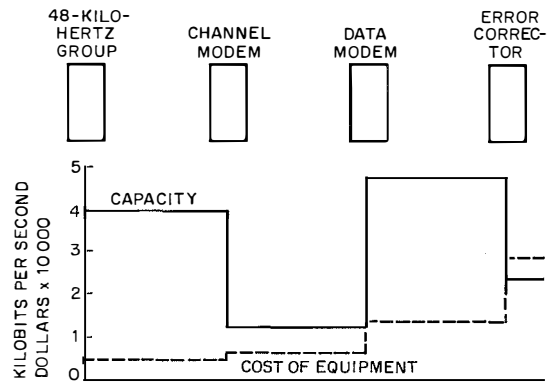

Figure 4—Impact of components of the data circuit on cost of equipment and effective capacity.

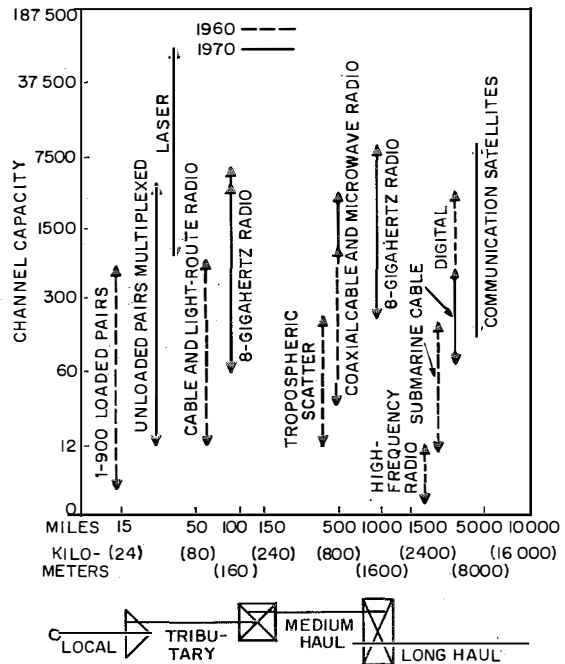

Figure 5—Developments in teletransmission through 1970.

accomplish this. If the length of the loop exceeded a loss of 15 to 20 decibels, negative-impedance amplifiers were added.

(B) In the tributary area, essentially the same multipair cable, unloaded and equipped with carrier systems of the short-haul type (*N* and *O*), provided 12 to 24 channels per pair. In more-recent years, line-of-sight microwave links for light-traffic routes began appearing with capacities of 60 to 240 channels. This equipment was of the type developed by the radio industry for industrial pipeline and power-line applications, generally in the 6-gigahertz band, frequency modulated.

(C) In the medium-haul area, coaxial cable, repeated and equipped with type *K* and *L* carrier systems having 60 to 420 channels, was the principal facility before 1950. Microwave of the *TD-2* type, using frequency modulation in the 4-gigahertz band, first appeared in the early 1950's under the impetus of network-television demand. By 1960, over half the total route channel miles of long lines in the United States were supported by *TD-2* microwave (see Figure 6) and the band was reaching congestion on the main routes.

(D) In the long-haul sector, the main traffic was carried by high-frequency radio links having 1 to 4 channels. Toward the end of the 1950's plans for long-haul submarine cable with 18 to 36 channels were well in hand.

By and large, teletransmission before the 1950-1960 decade was characterized by competition for channel capacity. The highest-capacity media, coaxial cable and 4-gigahertz microwave, were in the category of 400 to 600 voice channels. The remainder—twisted pair, unloaded cable, high-frequency radio, and submarine cable—were in the category of 1 to 60 channels.

There were other factors also at work. The advent of the transistor amplifier made it economical and feasible from the point of view of the power supply to remove the loading coil from the twisted pair, then equalize it on a

broad-band basis and insert repeaters for a useful bandwidth ranging from 500 kilohertz to a couple of megahertz, depending on the modulation method chosen. The capacity of the twisted pair rose from 1 to 24 channels. Allowing for a 50-percent reduction due to 4-wire working and for a percentage of pairs with adverse noise or crosstalk characteristics, the capacity of the twisted pair was raised by a 10-fold factor. A 1000-pair 1000-channel cable became a 10 000-channel cable. If the growth factor in this sector is 7.5 percent per year for a doubling every 10 years, then the requirement for loop or local transmission was solved for two to three decades.

The emergence of the laser, a facility that offers a capacity of several hundred channels per route, may result in still-more-economical bandwidth. In brief, in the short-haul sector, the situation has changed from one of strife for bandwidth to one of a potentially embarrassing surplus.

In the tributary area, we have begun exploiting the radio spectrum from 6 to 10 gigahertz, a spectrum in which propagation conditions due to water vapor and oxygen absorption effects are less favorable than they are in the band below 6 gigahertz. Here again, the economic

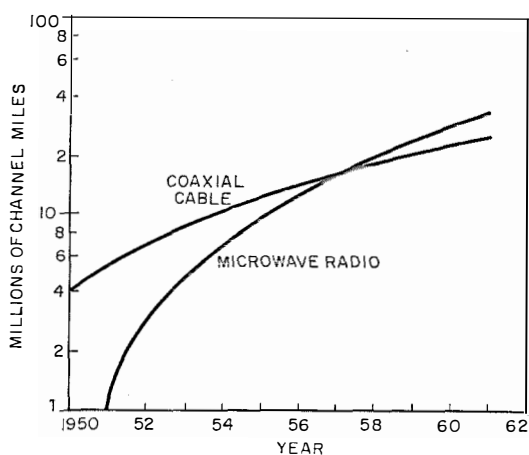

Figure 6—Trends in telecommunication by cable and by microwave radio.

optimum is 10 times the capacity for which we had designed tributary systems, about 2500 channels as against 250 channels. The band above 10 gigahertz is largely virgin territory. The propagation conditions are unfavorable for single-sideband multiplex. However, they may well be adequate for digital modulation where the signal-to-noise ratio requirements may be eased by as much as 40 decibels.

In the medium-haul area, the desirable 4-gigahertz band is approaching congestion on many of the routes in the United States. The Bell System has already begun introducing channels in the middle of the 40-megahertz spacings used earlier for type *TD-2*. However, the band from 6 to 10 gigahertz, given appropriate modulation methods, offers capacity for continued expansion for several decades.

In the long-haul sector, where capacity has been the historic obstacle and so scarce that such gimmicks as Time Assignment Speech Interpolation and 3-kilohertz spaced multiplex were being introduced to obtain small increments of capacity, something approaching a revolution has occurred. As in the case of the twisted pair, the advent of the transistor amplifier relieves the principal limitation that the

tube amplifier imposed on submarine-cable capacity—the possibility of feasible power supply to repeaters spaced as close as 10 miles contrasted with present-day 25-mile spacing. New submarine cables can now be conceived with a capacity of 600 channels instead of the 60 to 120 channels possible with vacuum-tube repeaters—an increase of 5- to 10-fold. In addition, the synchronous satellite, like the laser in the short-haul sector, can be economically justified only if it is built for a large number of channels (250 to 2500).

Thus, from short-haul to very-long-haul, transmission capacity has moved up by a clear decimal order of magnitude—a 10-fold augmentation. What has indeed happened in this short time is that we have advanced from the scarce-bandwidth corner of the transmission-capacity graph of Figure 7 to the scarce-power corner. The order of the day before the 1950–1960 era was modulation schemes that conserved the scarce bandwidth of the twisted loaded pair, open wire, high-frequency radio, and submarine cable; single-sideband suppressed-carrier modulation ruled the land. The situation in the post-1960 era is one of a range of transmission facilities in which the generation of high power is expensive or impossible, as in the case of lasers, 10-gigahertz radio, and satellites, but which offer the added compensation of wide to unlimited bandwidths. For the modulation designer, the rules of the game seem to be clearly shifting from the frequency-stable amplitude-linear domain to the time-stable phase-linear domain. The latter set of conditions spells out simply digital methods of modulation. And that scarcely can be viewed as a misfortune if half the traffic after 1975 is scheduled to take place in the digital mode.

With the strong trend toward high capacities, a companion trend in cost has also become evident. The installed cost of various types of facilities with their associated capacities is displayed in Figure 8. The trend is downward, from the order of \$1000 to \$3000 per channel-mile for facilities of 1 to 10 channels, to the

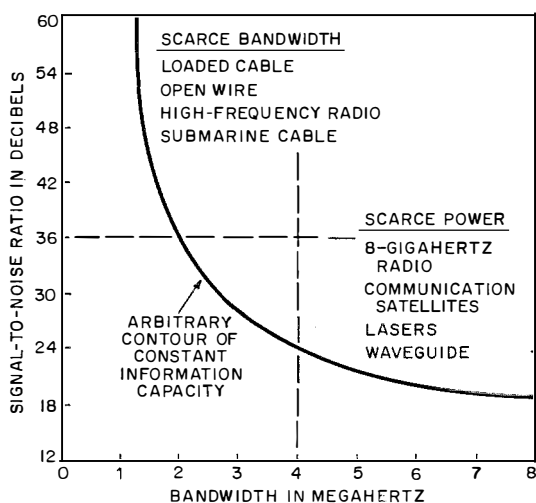

Figure 7—Transmission capacity in bits equals signal-to-noise ratio in decibels times bandwidth.

Data Transmission—Current Trends and Prospects

neighborhood of \$35 per channel-mile for facilities of 2500 to 5000 channels—a 100-to-1 reduction. Indeed, by today's economics of teletransmission, facilities that cannot be installed for about \$50 or less must be carefully weighed from the point of view of their salability and competitive survival in the coming decades—except where very-special circumstances (military, for example) clearly warrant an excess. The recently announced \$1 tariff for long-distance calls anywhere in the United States after 8 at night is not just evidence of an irrepressible public-utility goodwill, but of the new transmission economy.

The transmission story is thus one of high capacity and low cost. If this observation implies anything, it certainly must argue that the 10-year struggle of the datamen to extract more bits from their telephone channels at investments ranging from \$7500 to \$75 000 per circuit is no longer in consonance with the

economics of transmission. The terminal transducer that has flourished so bountifully in telephony, the telephone set, costs between \$15 and \$100 depending on the part of the world in which it is manufactured. If the large-scale data age is going to come to fruition and account for as much traffic as the telephone, it would appear that we should shift our sights from the preposterous numbers in the \$10 000 domain to something a couple of decimal orders of magnitudes lower—that is to say, \$100. Error correctors at \$100 000 make curious reading, but it will take \$100 input-output transducers to usher in the data age.

The transition from analog telephone transmission to digital transmission may have to be made in a single decade. Such a transition (returning to our forecast that fully half of our traffic in 1975 is going to be digital) is a monumental one. However, if we succeeded in a comparable decade in providing abundant

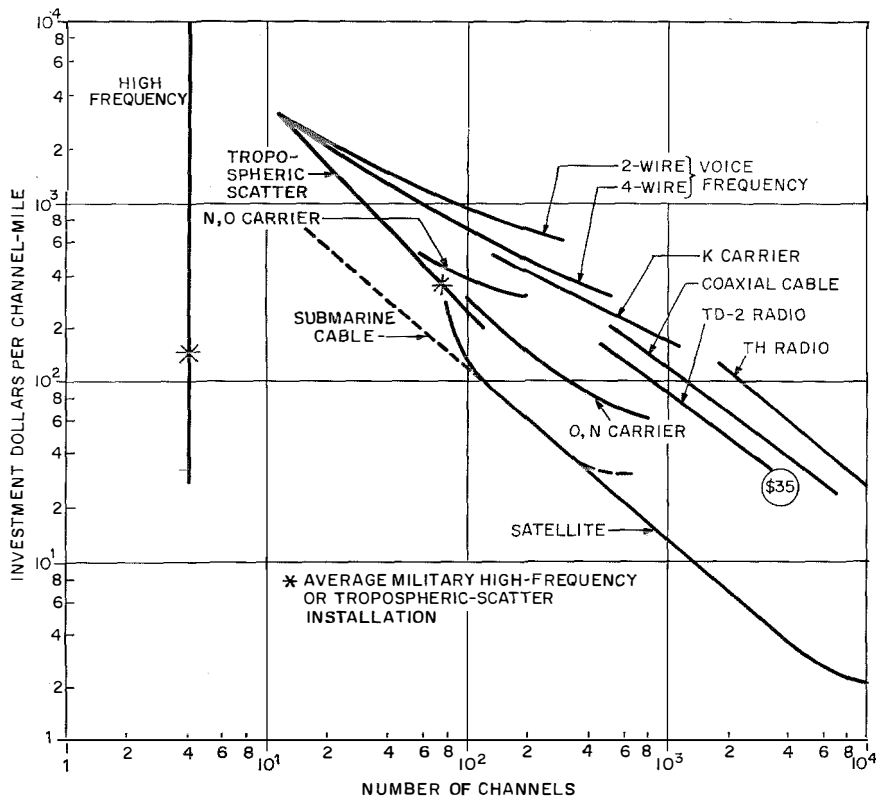

Figure 8—Costs of various transmission facilities as a function of the number of channels.

continental television transmission, we should be able to take this new revolution in stride—provided we view the potential pitfalls realistically and learn to pull together with some of the enthusiasm with which we were galloping in all possible directions during the past decade.

A cardinal principle of telephone evolution is the preservation of compatibility with the existing facility. The telephone facility has become so essential a part of our social, industrial, and military life that its disruption for any period poses a specter of national chaos that cannot be tolerated.

A fundamental parameter of the telephone plant today is its frequency-division-multiplexed structure—a highly standardized, modular, stable, and maintainable system, which is not only likely to endure in its present form but

is expanding at a phenomenal rate all over the world.

Single-sideband multiplexing is the telephone facility for dividing the wide-band capacities of its transmission plant into packages that can be sold to users. This internationally standardized system is given on the right-hand side of Figure 9 and in the upper part of Table 1. The basic packages derived from this system are the universal nominal 4-kilohertz telephone channel, the 12-channel 48-kilohertz group, the 60-channel 240-kilohertz supergroup, and the emerging 300-channel 1200-kilohertz master group. If the data man is going to be able to capitalize on this telephone plant, since he has none other and there is not likely to be any substantially new one for some time, he is bound to use one or another of these established highways.

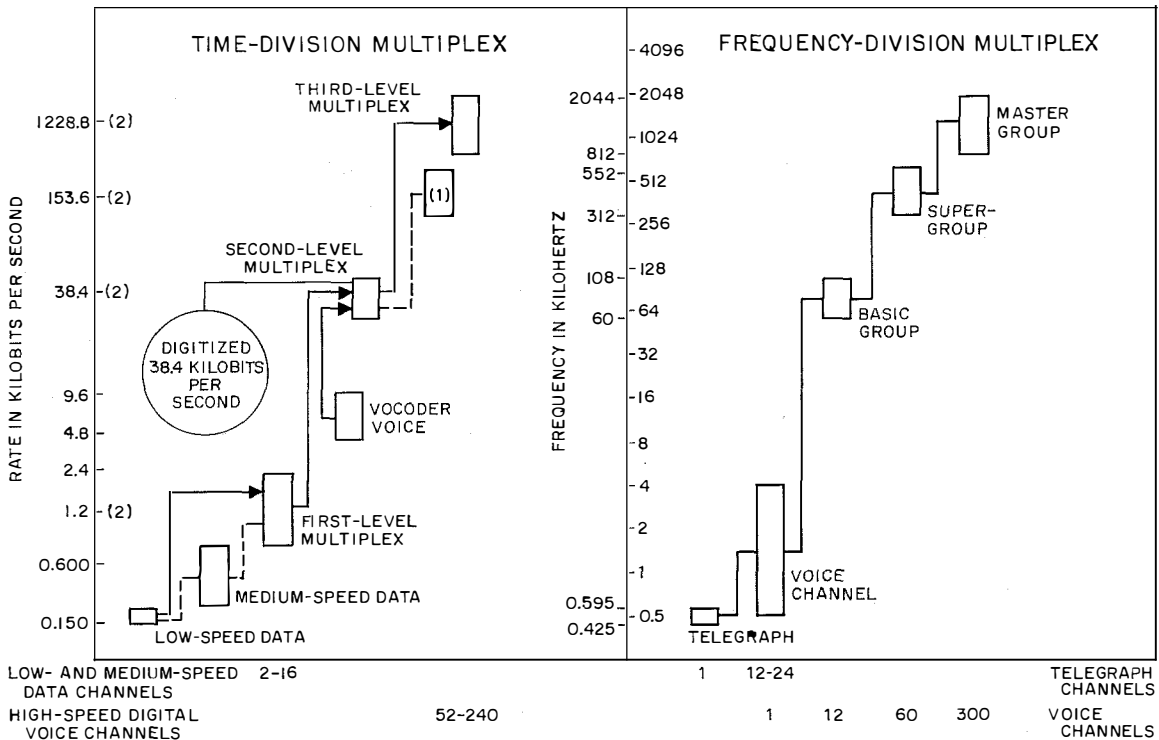

Figure 9—Multiplex comparison. (1) indicates the nonpreferred 153.6-kilobit-per-second time-division-multiplex transfer level to 240-kilohertz frequency-division-multiplex supergroup. Refer to Table 1. (2) The corresponding rates utilizing the 62.5×2^n formula would be 1.0, 32.0, 128.0, and 1024 kilobits per second.

Data Transmission—Current Trends and Prospects

It is thus necessary to follow suit and establish a spectrum of data channels that corresponds to the capacities of the telephone highways on the one hand and to the needs of users on the other. In addition, it is necessary for the data man to establish a hierarchy of his own, suited to the parameters of digital transmission. In some respects these approaches bear a close analogy to the frequency-division-multiplex situation, in which the successive capacity groups are multiples of each other: 1, 12, 5, and 5 for the channel, basic group, supergroup, and master group. In the digital world it is necessary to preserve a different kind of order. The digital designer's operation is a binary one. In his world the desirable scheme is one in which each higher

trunk facility is a binary multiple of the one below. Efficient multiplexing can be achieved if speeds are rigidly synchronous.

The generators of digital information would begin with the start-stop teleprinter operating at 60 to 100 words per minute. In the spectrum of digital speeds, which are gaining general acceptance and are defined by the number 75×2^n , the lowest speed into which teleprinter outputs can be buffered and transmitted synchronously is 150 bits per second.

The next user would operate at 600 bits per second, a speed that is not yet widely used but for which paper-card and paper-tape punches are available, and for which readers can be

TABLE 1
MULTIPLEX COMPARISON

Frequency-Division Multiplex				
Derived Unit	Transmission Unit			
	Voice Channel (4 Kilohertz)	Basic Group (48 Kilohertz)	Supergroup (240 Kilohertz)	Master Group (1200 Kilohertz)
Telegraph channel, 170 hertz (120, 150 hertz)	12 to 24			
Voice channel, nominal 4 kilohertz	1	12		
48-kilohertz band			5	
240-kilohertz band				5
Time-Division Multiplex				
Derived Unit	Transmission Unit			
	1200-to-2400 Bits per Second*	38.4 Kilobits per Second	153.6 Kilobits per Second	1228.8 Kilobits per Second
Telegraph channel, 150 bits per second	8 to 16			
General-purpose medium-speed data channel, 600 bits per second	2 to 4			
1200 to 2400 bits per second	1	32 to 16		
Compressed-speech vocoder channel, 4.8 to 9.6 kilobits per second		8 to 4		
High-speed digital voice channel, 38.4 kilobits per second		1	4	32

* Multiplex staging-level choice between 1200 and 2400 bits per second not presently determined.

built fairly economically and designed to work reliably. This is the potential realm of the general-purpose medium-speed data terminal. It is also a speed that can be transmitted over switched telephone channels by means of simple reliable modems at relatively low error rates.

Higher up the scale are the speeds required for vocoded speech at 4800 to 9600 bits per second, and 38.4 kilobits per second for directly digitized speech and computer-to-computer transmission.

If, therefore, we choose 150 and 2400 bits and 38.4 kilobits per second as the 3 fundamental staging levels corresponding to the telegraph, telephone, and basic-group stages of frequency-division multiplex, we obtain a 2-level multiplex system in which the levels are related to each other by the binary number of 16. The 2400 bits can be multiplexed upward or routed via a high-grade telephone channel by means of a 4-phase data modem. The 38.4-kilobit-per-second trunk can be either transferred over a 48-kilohertz basic group or multiplexed into a 1228.8-kilobit-per-second train for direct transmission over repeatered unloaded pair, submarine cable, and potentially the master-group channel of the telephone plant.

The essential requirement is a rigid standardizing of channel rates in a binary commensurate scheme. If we proliferate speeds of 750, 1000, 1300, and 2000, we may satisfy conscious or subconscious drives for diversity, but we will be repaid in multiplexing chaos, inefficiency, and inflexible one-to-one connections.

Certain other items of the datamation hardware have to be rigidly standardized. Obviously, there cannot be any freedom in choice of modems. It is necessary for the common carriers to remove these devices from the inventive diversity of users and absorb them into the telephone plant so that demodulation and regeneration may be accomplished flexibly and uniformly through the switching points of the plant and under the integrating control of one authority.

No such stultifying rigidity, however, need be extended to the terminal devices.

Built-in incompatibles should be scrupulously avoided. One of these has already been developed and, if we do not correct its direction shortly, it will be an accomplished fact and will be with us for years if we let obsolescence run its course. I refer to the classical pulse-code-modulation system described in Table 2.

TABLE 2
CONVENTIONAL PULSE-CODE MODULATION

Sampling rate in kilohertz	8
Bits per sample	7
Total kilobits	56
Number of channels	24
Total kilobits	1334
Broadcast channels	23*
600-bit channels	24-48
150-bit telegraph channels	250

* 1 synchronizing order-wire channel is included.

It was devised in the early days of digital development and was based on the reasoning that, since voice occupies a spectrum of about 3500 hertz and that, to reproduce a constant-level sinusoidal signal it was necessary to sample at a minimum of twice per hertz, a sampling rate of 8 kilohertz had to be chosen. This rate of sampling also allowed adequate space for the skirts of a filter required to remove the sidebands of the sampling carrier from the receiving terminal. With the voice extending over a dynamic range of 25 decibels, and with line-loss variations accounting for another 15 to 25 decibels, it was determined that 128 levels or 7 bits would be required to code the "vertical" dimension of a speech signal. Moreover, since technology and transmission limited the width of pulses to about 1 microsecond, and since the bit rate of one channel sampled at 8 kilobits per second and 7 bits per sample is a rate of 56 kilobits, 24 channels produced a trunk speed of 1334 kilobits per second. The system provided 23 voice channels and one synchronizing order-wire channel. Alternatively, by adding another 56 kilobits and raising

the speed to 1390 kilobits per second, the number of channels could be increased to an even two dozen.

This is the pattern to which most of the conventional pulse-code-modulation systems, old and current, adhere. Observe, however, that there is not a single number in this whole scheme that is a binary multiple of any of the standard rates in the 75×2^n spectrum. To put 600, 1200, or 2400 bits on this digital system, some form of complex speed conversion is required. Otherwise we would be back where we were before the digits. We would derive nominal 4-kilohertz analog voice channels from the clean digital train, then proceed to install a data modem to convert the digital inputs to a form suitable for transmission over an analog channel! With the additional aid of \$7500 data modems, we would succeed in obtaining 24 channels each of 2400 bits per second (57 600 bits per second in all) from a 1390-kilobit train. That would be an efficiency of about 4 percent.

The rapid expansion of pulse-code modulation based on the 8-kilohertz sampling rate in the telephone plant makes it increasingly unlikely that a comparable revision of standards can be introduced. In order then that efficiency and low cost of data transmission over such facilities may be assured, it seems urgently necessary to reconsider the 75×2^n data speed formula which yields numbers like 1200, 2400, and 38 400 bits per second relative to a 62.5×2^n formula which yields numbers like 1000, 2000, 8000 bits per second, et cetera.

The prospect of abundant low-cost digital transmission capacity is clearly within reach. If, however, extensive and rigid standardization and compatibility are not enforced, that prospect will elude us. If we miss it, the price penalty would be something of the order we have indicated in the discussion of conventional versus compatible pulse-code modulation—an efficiency penalty and eventually a transmission cost penalty of 10 and 20 to 1.

It is easy to sympathize with human opposition to the frequently stultifying hand of standardiza-

tion. However, our emotions should not blind us to the painful penalties in cost of the present current of chaotic and undisciplined diversification. We need look no further than the international anarchy in television and telephone signaling standards to appreciate the consequences.

5. Where Will the Bits Come From?

It is evident from the preceding discussion that the economic and technical conditions now exist for the advent of large-scale low-cost data transmission and that it is well within the grasp of the engineering and engineering-management community. Meanwhile, however, we face some rather difficult and basic problems. If half of the traffic in the telephone plant in 1975 is going to be digital, just where will all the digits come from?

In the early days of steam engines, a measure of engine power was devised in terms of horses. It gave the layman some intuitive indication of how big an engine was. The equation between engines and horses is not a very-accurate one, but it does provide a garden-variety measure of magnitudes, even though a 300-horsepower automobile motor is indeed equal to 300 very-particular horses under a very-particular kind of test. What similar basis, if any, do we have for comparison in the data field?

The capacity of a human being to generate and absorb relatively nonredundant information is roughly 50 words per minute. Depending on how the alphabet is coded, 50 words become various numbers of bits per second. Fifty bits per second is an approximate though adequate equivalent for comparison. We will therefore call 50 bits per second 1 Man Information Capacity—*MIC* for short and for levity.

If we carry out these estimates further, we find that 2400 bits per second for 1 hour is equivalent to about 200 000 words or about 50 hours of reading. In other words, a 2400-bit-per-second data circuit, operating for a typical 3-minute call on a telephone circuit, is comparable

to 50 voice calls in information content. The information rate of 38.4 kilobits per second is roughly equivalent to that of 750 human beings (750 *MICs*!).

Clearly, if we are talking about a digital age, we are not talking about communication between human beings. The teleprinter at 60 words per minute is a practical fit insofar as conversations between human beings go. What are we talking about then?

I think we are talking about an information world with which human beings will have to work, not directly but indirectly. Let us consider the boundaries of this world.

The information milieu in which man operates in this mid-century has changed radically from that of the days of the steam engine and even that of the birth of the automobile. For example, the contemporary family doctor is, in our time, coping with obsolescence. The number of drugs, the diagnostic practices, the range of maladies that his clients once bore and now demand to have corrected, have changed vastly. In any serious disorder, a patient must be prepared from the outset for a long and weary pilgrimage to a large number of specialists. Such a "forced march" is not surprising if we consider the intricate biologic structure of the human organism and its highly ramified network. It is infinitely more complicated than a television set. The practice of medicine requires effective and speedy access to a vast amount of information, which is growing daily through the contributions of legions of researchers in all areas of science.

The engineer and the technologist are at grips with a similar obsolescence problem. No engineer is naive or brash enough to believe he can cope with the Niagara of technical literature produced in his own narrow area of specialization: developments in materials, components, theoretical methodologies, and the like. This is true not only of the electrical, chemical, mechanical, and civil engineer and the physicist, but of the very-narrow specialists in any one of these disciplines: the antenna and propaga-

tion specialists in the communications subdiscipline of the electrical-engineering profession, or the rocket-fuel specialists of the inorganic-chemistry subdiscipline of the chemical-engineering profession.

The gargantuan nature and scope of the information explosion may be illustrated by a space operation like the Nimbus weather satellite. When completed and operational, this weather station will gather the equivalent of 40 kilobits of weather data 24 hours per day, equal to the absorption or generation capacity of nearly 1000 human beings working 24 hours a day or 3000 working in 8-hour shifts.

What has happened, in effect, is that we have created an information world beyond access to those interested in its contents. More important, we are adding to this information Vesuvius at a "compound-interest" rate of approximately 25 percent per year. The level to which the society of contemporary man has propelled itself is sustained on a breadth and depth of information exchange with its environment that has exceeded for some time the human information mechanism. In many areas, particularly in those of technological development, we are plowing fields we have researched for the second, third, or tenth time because of the lack of effective search and retrieval methods. Our capability for further technological and social progress is becoming hopelessly choked by an information jungle of our own making. Among the many fields in which we have been unable to operate rationally because of our inability to deal with the vast quantities of information involved are those of the business, government, economic, and social spheres. In these, as in many others, we continue to navigate by instinct, prejudice, crystal ball, and consultations with astrologists. With respect to information, we are in much the same position as we were in the mid-eighteenth century with regard to earth moving. We are using picks and shovels where power scoops and steam shovels are required. In time, this situation will have extended to the typical household—where investment in stocks, what

Data Transmission—Current Trends and Prospects

kind of a vacuum cleaner is best, which brand of cornflakes contains the fewest calories, et cetera, will become mounting information challenges. We have succeeded in automating the information processing and retrieval function in but a few isolated places like accounting, banking, airline reservation systems, and certain defense control situations—in short, in extremely narrow and specialized areas.

There is, however, a solution to our information quandary, one that will inevitably require the partnership of three entities: the user, the telephone network, and the computer builder and operator. Imagine, if you will, a chain of a dozen or more automated information and retrieval (computer) centers with designated specialties (propagation, acoustics, circuits, telemetering, modulation, et cetera), located near the research laboratories or educational institutions that already represent a significant concentration of talent and library information. Imagine the same situation in medicine, economics, chemistry, psychology, and other fields. Imagine also that the familiar telephone instru-

ment has been equipped with a typewriter-like facsimile device so low in cost that anyone, or at least the professional society whose livelihood is associated with processing information, can afford it. Imagine that it is possible to obtain from a directory the “telephone” number of an automated “consultant” and the possibility that a query can be typewritten or, in the case of a certain diagnostic situation, presented in pictorial form for analysis. The query or offered information is directly transmitted to a likely consultant. The computation center may, in turn, automatically consult its own directory for another center known to be more “informed.” The cost of the service is billed to the subscriber in much the same way that telephone services are billed today. (See Figure 10.)

At first sight, such a system sounds farfetched. Yet a moment’s reflection reveals that such a system does, in fact, exist, and has been operating in a cumbersome fashion for centuries in the publishing industry. Every specialty and profession is served by a vast publication enterprise with centers staffed by information col-

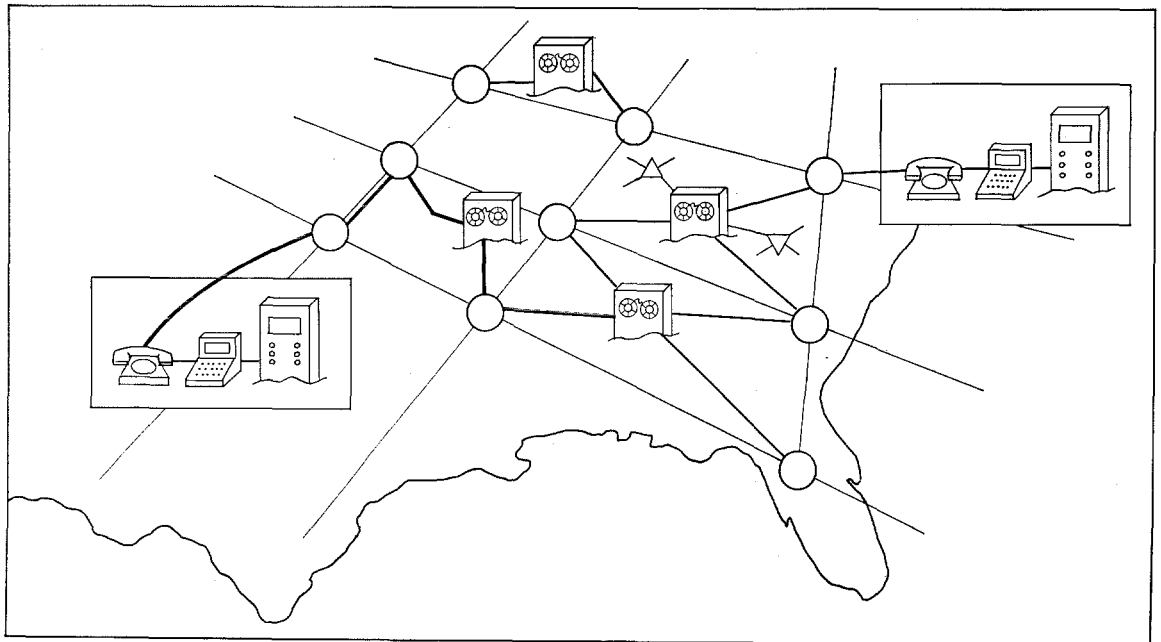

Figure 10—Integrated information management.

lectors and processors in various fields. They offer their output in a hit-and-miss method of trying to find material that interests some vague mean or large number. The service is provided through subscription solicitations. It is not a particularly efficient system. The percentage of the content of professional magazines and books read by subscribers is relatively small, and the business of finding what you want when you want it is painfully laborious.

It will be from these and related enterprises that the digits will come. The telephone network will, in time, gain a new world of subscribers; the public-service computer and the general-purpose subscriber-access device. On the human interface side of the computer, human and quasi-human digital information rates will range from perhaps 75 to 600 bits per second. On the computer-to-computer interface side, rates will range from perhaps 1200 bits to 50 kilobits per second; on trunks, multiplexed rates in megabits per second or megahertz in accord with whether the medium is adaptable to time- or frequency-division multiplexing.

The private-service computer, owned and operated by a single firm for production control, accounting, and like purposes, has a predictable and foreseeable saturation point. The public-service computer has no predictable limit. The realization of the latter requires, above all, a subscriber input-output device in the \$100

J. W. Halina served in the Canadian army in the second world war after which he entered his second academic round, by graduating as an electrical engineer from the University of Toronto. He then worked on microwave relay and radar engineering for the General Electric Company.

After joining the International Telephone and Telegraph System, he contributed importantly to the design of a short-haul double-sideband suppressed-carrier multichannel telephone system for transmission over unloaded cable.

bracket; a low-cost, flexible, and universally switchable transmission facility; and institutions like the publishing, editorial, and abstracting enterprises of today operating and offering automated information processing and retrieval services—an adaptation, conceivably, of the *Sage* concept to the vast and chaotic world of information in general.

There is little question, therefore, as to where the digits are. The real question is: Can we organize them into useful and dynamic information systems? Have the users, common carriers, and computer makers the will to overcome the obstacles?

6. References

1. Enticknap and Schuster, "Sage Data System Considerations," *Communications and Electronics*, number 40, pages 824-832; January 1959.
2. J. W. Halina, "Banking Automation—Where Next?," *Proceedings of the National Automation Conference of The American Bankers Association*; 1963.
3. J. W. Halina, "The Telephone Channel in a Global Communications System," *IRE Transactions on Communication Systems*, volume CS-9, number 3, pages 247-252; September 1961.

When ITT Communication Systems was established in 1959 to engineer worldwide telecommunication systems, he was assigned to it, becoming successively director of engineering and deputy to the vice president. He was recently transferred to the headquarters of ITT Europe in Brussels.

Mr. Halina has contributed frequently to technical journals on subjects dealing with communication and information systems.

Instrument Low-Approach System and Radio Altimeter for All-Weather Landings

W. L. GARFIELD

F. T. NORBURY

Standard Telephones and Cables Limited; London, England

1. Introduction

Over the past 5 years much attention has been directed by airlines to methods of meeting schedules despite variable and largely unpredictable weather. At the technical meeting of the International Air Transport Association held at Lucerne in the spring of 1963, the general opinion was that the instrument low-approach system and the low-level precision radio altimeter would form the radio elements for those aircraft guidance systems that would be developed in the near future, particularly for the approach to the landing runway.

2. Typical Low-Approach and Automatic Landing Systems

Not unnaturally, cost plays a large part in overcoming the effects of bad weather. Also, different parts of the world have different requirements and weather problems. At its 7th session, the COM Division of the International Civil Aviation Organization laid down 3 categories of all-weather operation and thereby established goals of performance for each. The vast majority of operators believe that if they can operate reliably in Category II, they will have answered their most important problems.

However, many of the systems to meet Category II requirements, which are now being implemented, are not capable of extension to provide Category III operation. Such systems are known as low-approach systems.

On the other hand, there are automatic landing systems that can provide what is basically operation to Category III standards. These systems will implement the programs bit by bit, first to Category I, then Category II, and finally to Category III operational certification. There is no doubt that the use of such equipment in the lower categories is the more costly approach, but it would seem to have an excellent safety margin when used at Category II operating

level because it has the potential of eventually providing full Category III operation.

It is worth stating that whilst the attainment of Category II operation is reasonably imminent and will be achieved by some operators in 1965, Category III operation is much further away and may not be fully attained until 1970.

3. Instrument Low-Approach System

Beginning in 1946 instrument low-approach systems meeting the standards of the International Civil Aviation Organization have been installed at many airports and in the majority of aircraft. Until recently their role in the main has been limited only to low-approach guidance, since the overall accuracy and stability were not adequate for the final stages of descent and landing.

The two main components of the instrument low-approach system with which the authors are concerned are the localizer equipment providing azimuth guidance and the glide-slope equipment providing guidance in the vertical plane. The localizer, which operates in the frequency band from 108 to 112 megahertz, is situated beyond the stop end of the runway. Its radiation pattern defines a vertical plane that provides guidance in azimuth along the extended centre line of the runway. The glide-slope equipment, operating in the band from 328.6 to 335.4 megahertz, is situated to one side of the centre line near the approach end of the runway. Its radiation pattern defines a sloping plane providing guidance down to the runway. The intersection of these two planes defines the course line of the approach guidance.

In addition, 75-megahertz marker beacons are located at prescribed positions on the course line. They radiate coded signals indicating distance to touch-down.

The instrument low-approach system was discussed in this journal in a paper [1] that described a new and improved design of mobile ground equipment, the *AN/MRN-7, -8*. Further improvements were made in an equipment called the *STAN/7/8*. The excellent performance of all these equipments was immediately manifest in the prototype trials and gave the first real promise of the feasibility of using instrument low-approach systems for all-weather landings.

The purpose here is to consider the main performance parameters of the instrument low-approach system together with the sources of error and interference, and to see how improved performance and serviceability have been obtained in the *STAN/7/8* equipments. The experience obtained with these equipments in service so far shows that they perform uniformly, produce accurate linear course guidance signals, and possess inherent stability of high order without automatic course correction. These equipments have set a high standard of reliability. They are immediately available for service on turn-on and permit greatly reduced re-alignment and maintenance routines compared with previous designs.

Many successful automatic landings have been performed using normal operational equipment, and guidance down the runway has been found to be satisfactory for both landing roll-out and take-off.

An extensive series of tests and stability measurements have been recorded by British authorities in their evaluation of the *STAN/7/8* equipments to provide service that meets Category II performance standards of the International Civil Aviation Organization, and it is considered highly probable that the performance achieved will be adequate also for Category III all-weather automatic landing.

One of the requirements to provide this ultimate category of service is that the overall system reliability must be such that the average fatal-accident rate should not exceed 1 in 10^7 landings. This requirement increases the order

of reliability demanded from the constituent elements of the system, of which the ground equipment is only one part. To this end, new equipment design concepts are necessary and more-comprehensive monitoring must be incorporated.

3.1 BASIC REQUIREMENTS

The significant signal in both localizer and glide-slope systems is the difference in depth of modulation between two waves, one modulated at 90 hertz and the other at 150 hertz. The difference in depth of modulation is zero on the course line and increases linearly with angular deviation to reach a prescribed value at a specific sector width angle. The 90-hertz signal is predominant on the left of the course line and above the glide slope causing a fly-right and fly-down indication in the aircraft. The reverse indications are given by the 150-hertz signal.

The most important end result is the distance by which the aircraft is displaced from the lines of zero difference in depth of modulation, due to overall system errors and to interfering signals when the aircraft is at or near the landing threshold and at the point when no time remains for corrective manoeuvres.

By the International Civil Aviation Organization standard, the localizer course line intersects the glide slope at a height of 50 feet (15.25 metres) above the runway threshold, where the localizer sector width is such that displacement of 350 feet (107 metres) corresponds to 0.155 difference in depth of modulation. This condition gives full-scale right-left deflection of the aircraft indicator and corresponds to an angular deviation of 2 degrees subtended at the localizer centre of radiation at a point 10 000 feet from the threshold; thus displacement in feet at the threshold equals 2258 times the difference in depth of modulation.

For the purpose of this discussion, the glide-slope angle is taken as 2.5 degrees with respect

Low-Approach System for All-Weather Landings

to the runway surface, and the angular deviation or "width" setting as 0.5 degree for full-scale deflection equivalent to 0.175 difference in depth of modulation; thus at the threshold the vertical displacement in feet above or below the glide slope is nominally 10 feet (3.05 metres) for full-scale up-down deflection of 0.175 difference in depth of modulation (57 feet \times difference in depth of modulation).

3.2 ERRORS AND INTERFERENCE

The extent that the aircraft is displaced from the true course lines depends on the following factors.

(A) Fixed and variable errors in both the ground and airborne components of the instrument low-approach system.

(B) Beam interference, both fixed and variable, arising from external influences such as reflection of the radiated signals from site obstructions, irregular terrain, moving vehicles, et cetera; reflections from overflying aircraft, whereby doppler-frequency error signals at or near 90 and 150 hertz may be encountered; rogue radio-frequency transmissions at similar carrier frequencies; and anomalous propagation of distant co-channel instrument low-approach systems.

(C) Auto-pilot errors and aerodynamic effects of the aircraft and its auto-pilot system caused by noise signals and by wind conditions such as cross-wind, wind shear, and gustiness.

The effects of (C) are likely to contribute the largest proportion of the total error; thus of an allowable maximum deviation, only a small proportion can be allotted for the ground-equipment error of the instrument low-approach system.

Further, the response of the aircraft and its auto-pilot to certain dynamic errors necessitates imposing an extremely close tolerance on the amplitude and frequency of noise deviations of the course lines over the final approach region. Similar performance parameters apply to both localizer and glide slope. The localizer however must be held to closer tolerances since

it is used down to and along the runway surface.

The present Category II operation standard of the International Civil Aviation Organization makes it necessary for the instrument-low-approach ground monitors to alarm for a course-line shift of the localizer exceeding 25 feet (7.6 metres) at the threshold. The amplitude of beam bends is not permitted to exceed 0.005 difference in depth of modulation over the final 3500 feet (1067 metres) of the approach to the threshold. At this point the amplitude is equivalent to a deviation of 11.3 feet (3.4 metres).

Beam disturbance may be due to a number of causes. The principal causes are signal reflections from stationary and moving objects, and the reception of rogue radio-frequency signals of similar frequencies.

The interference pattern in space resulting from the simultaneous reception of the direct-path signal and those reflected from stationary site obstacles will be converted into long-duration low-frequency noise signals by the velocity of the aircraft. Similarly, reflections from moving vehicles or overflying aircraft may give short periods of noise of excessive amplitude. The reflections from the high-speed approaching and overflying aircraft operating at high speeds are capable of producing beat frequencies at or near 90 and 150 hertz, and thus can severely affect an aircraft directly controlled by the instruments in the final stage of approach.

When the effects of the various types of errors has been fully assessed, it is concluded that, if the instrument low-approach equipment intended to provide Category III operation is to provide adequate performance reliability, the main guidance signal characteristics must have closer tolerances and the radiated signals must be confined to the smallest volume of air space practically possible.

To exemplify the order of performance improvement achieved by the *STAN/7* localizer, the course-line-shift alarm level is set at 0.006 difference in depth of modulation, corresponding to a deviation at the threshold of 13.5 feet

(4.1 metres). The standard deviation of this error, derived from measurements taken at 1-minute intervals over a period of one month, is 1.5 feet (0.46 metre).

Similarly, for course "width" or sensitivity the standard deviation of shift of the point of intersection of the line of 0.155 difference in depth of modulation and the extended runway threshold—nominally 350 feet (107 metres) offset from the course line—is less than 10 feet (3.05 metres). For the other main parameters, the standard deviations are less than the following.

Modulation sum (change of the sum of the tone modulation depths from the nominal value of 40 per cent)	0.15
Radio-frequency level in decibels	0.25
Tone frequency in per cent	0.02

The problems of beam bends caused by signal reflections relate to the type of aerials used and their resulting radiation patterns.

It may be noted here that with the highly directive main-course aerial used for the *STAN/7* localizer, the beam pattern of which extends in azimuth only to ± 12 degrees about the course line, the maximum bend amplitude due to reflection of extraneous side-lobe signals radiated outside this sector is only 0.012 difference in depth of modulation even for reflection of 100 per cent; in practice this error is unlikely to exceed 0.0025 difference in depth of modulation.

3.3 MAIN CHARACTERISTICS OF TRANSMISSION

Basically the same transmission system is used for both the localizer and the glide-slope equipments. The only differences exist in radio-frequency circuit components which are made necessary because of the different carrier frequencies.

Both systems require the generation of the same two types of signals for the aerials and produce a null-reference mode of operation. These are:

(A) Carrier and sidebands consisting of a car-

rier that is amplitude modulated to precisely equal depths by tones of 90 and 150 hertz. The modulation depth for each tone is 20 per cent in the localizer and 40 per cent in the glide-slope equipment.

(B) Sidebands without carrier consisting of both amplitude-modulated sidebands of each of the two tones. These are precisely equal in amplitude but in radio-frequency antiphase. The sidebands of one tone are of the same relative phase as those of the carrier-and-sidebands signal.

The relative amplitude of the sidebands-without-carrier signal determines the course width or sensitivity to the difference in depth of modulation.

The success of the equipment depends on the accuracy and stability achievable in the generation, control, and transmission of the amplitude, phase, and frequency of these two signals. For example, the actual standard deviation of localizer course-line shift of 18 inches (46 centimetres) at the threshold, if due solely to unbalance of the tones, would be caused by a change of 0.066 per cent in the modulation depth of one tone.

3.3.1 Transmitter

The complete operating transmitter for both the localizer and glide-slope equipments is contained in one cabinet with front and rear access doors. Duplicate cabinets provide working and standby equipments. Separate from the cabinets is the common automatic changeover equipment.

The equipment is assembled in functional units. The units are easily withdrawable. Many units are common to both localizer and glide-slope equipments. All monitoring receivers are identical, the particular function being determined by a plug-in attenuator sub-unit. All monitoring receivers are calibrated to the same parameters.

Figure 1 shows the localizer cabinet, which contains both the course and clearance transmission channels. The mechanical modulator,

Low-Approach System for All-Weather Landings

power-combining and dividing bridges, phasers, et cetera, are accessible from the rear.

Forced air ventilation is ducted to individual units and the general cabinet cooling is such that the average rise of air temperature above room ambient does not exceed 5 degrees Celsius. To achieve the desired performance stability, the transmitter room is controlled to be between 20 and 40 degrees Celsius.

When not connected to the aerial, the transmitter outputs are automatically terminated in loads enabling full operating conditions to be tested.

Three modes of control are selectable: complete remote switching with back signaling, local control, and by-pass control in which the equipment is removed from the automatic change-over control for testing. The monitor alarm circuit may be muted to prevent changeover during the alignment procedure.

3.4 MONITORING

The quality checking of the guidance information radiated depends on the accuracy and stability of the monitoring system, which in turn depends for its calibration on the accuracy of test gear. By the use of special 2-tone test gear, the monitors themselves become precision measurement standards and have an initial accuracy of ± 0.00075 difference in depth of modulation, permitting alignment of the course line to within ± 0.01 degree.

Near-field course-line and sector-width monitoring dipoles with temperature-controlled amplifying and detecting circuits pass the guidance signals at an intermediate frequency of 130 kilohertz to the accurate monitoring receivers in the transmitter equipment. The eventual direct voltages resulting from deviations of the signals from nominal values operate alarm circuits to shut down the operating transmitter and automatically change over to the standby transmitter. The course-line and sector-width errors are also indicated on centre-zero instruments.

A portable monitor for difference in depth of modulation of equal accuracy is used at marked near-field positions for checking alignment and sensitivity. Its measurements are compared with a near-field vectorial analysis accomplished by a computer. This monitor is also used with a 70-foot (21-metre) telescopic aerial mast for monitoring at the runway threshold. It is current practice to carry out realignment checks every 6 months.

The major source of error common to both fixed and portable monitors is the differential drift of the 90-hertz and 150-hertz filters. The test limit for this error is 0.0012 difference in depth of modulation over the temperature range from 20 to 40 degrees Celsius with frequency variations of ± 1.25 per cent.

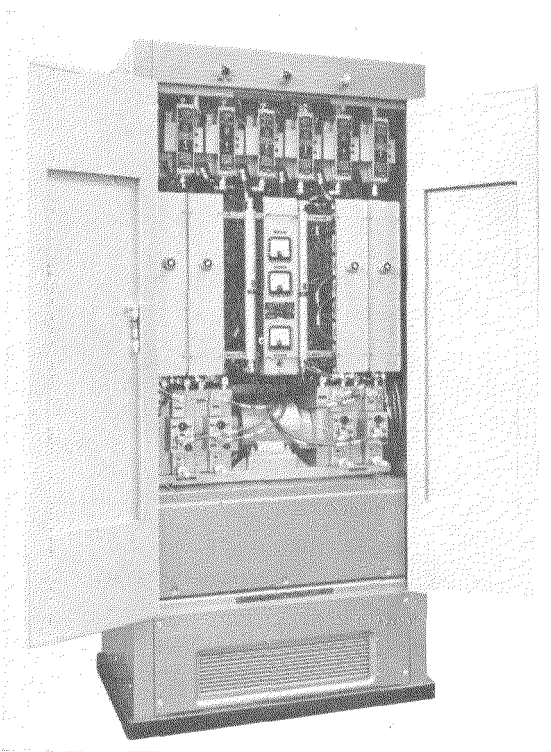

Figure 1—Rear of localizer transmitter. Along the top are 6 reflectometers with 3 meters for them centrally below. The motor for the mechanical modulators is visible just below the meters.

The localizer course-line monitor alarms at a deviation of 0.006 difference in depth of modulation, which corresponds to displacement of 13.5 feet (4.1 metres) at the runway threshold. The International Civil Aviation Organization specification limit for this parameter is 25 feet (7.6 metres).

The glide-slope position monitor alarms at a shift of 0.048θ (θ being the glide-slope angle relative to the surface of the runway) corresponding to displacement of 2.4 feet (0.73 metre) at the threshold. The International Civil Aviation Organization requirement for this alarm sensitivity is 0.075θ .

The stability of operation of the monitors, as derived from measurements taken on the localizer under normal conditions at 1-minute intervals for 1 month, is such that the standard deviation of centering error (apparent course-line shift) is less than the equivalent of 1-foot (0.3-metre) displacement at the runway threshold.

3.5 LOCALIZER AERIALS

Figure 2 shows the *STAN/7* localizer aerials in a typical installation at London Airport. The installation consists of the main highly directive course aerial and, 50 feet (15 metres) behind, the subsidiary omni-directional "clearance" aerial. Between the two aerials and recessed into the ground is the building that houses the transmitter equipment. The course aerial is a broadside array of 12 horizontal wide-band dipoles mounted 9 feet (2.7 metres) above ground in front of a reflecting screen of horizontal wires 85 feet (25.9 metres) long and 12 feet (3.7 metres) high. The carrier-and-sidebands signal passes symmetrically in a graded distribution in phase across the array, producing a narrow main lobe of radiation centered on the course line with zero signal at ± 11.75 degrees in azimuth. Beyond this angle, side lobes occur out to ± 90 degrees. The maximum amplitude of these lobes is 5.1 per cent. Since this radiation is a signal of zero difference

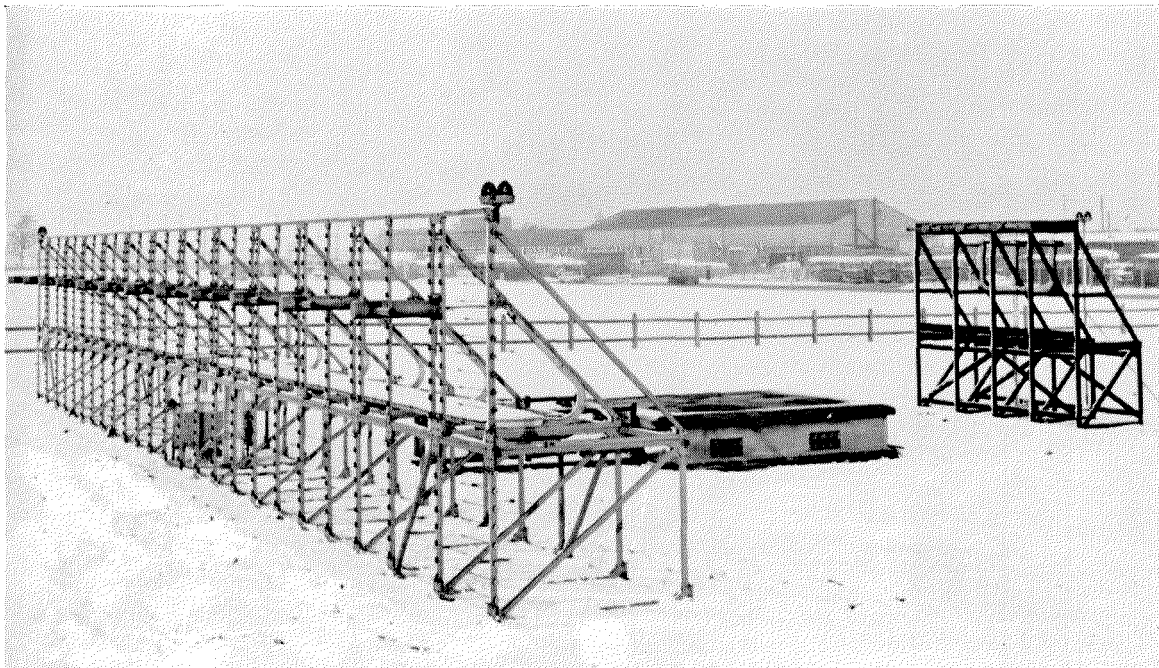

Figure 2—*STAN/7* localizer aerials at London Airport.

Low-Approach System for All-Weather Landings

in depth of modulation, reflection of any part of this radiated pattern will not deflect the course line but will cause only a small change in carrier level.

The sidebands-without-carrier signal passes in a graded distribution symmetrically across the array but in antiphase about the centre such that the signals on the two halves are ± 90 degrees with respect to the carrier-and-sidebands signal. This arrangement produces two main antiphased lobes of radiation equally spaced about the course line, with zero signal on the course line.

The maximum signal occurs at ± 5 degrees, but again the signal becomes zero at ± 12.75 degrees. Beyond ± 12.75 degrees, side lobes occur out to ± 90 degrees. Since this radiation is the signal that produces the course deflection, reflection of any part of it will cause disturbances of the course line and sensitivity of the difference in depth of modulation. The sum pattern of the two radiated signals is that of two narrow main lobes overlapping on the course line. At any angle the addition of the sidebands-without-carrier signal to the carrier-and-sidebands signal increases the modulation depth of one tone and reduces that of the other tone by the same amount. The difference in depth of modulation thus formed increases linearly with angular deviation from the course line. The amplitude of the sidebands-without-carrier signal is adjusted to give the required sensitivity of difference in depth of modulation.

When so set, the maximum amplitude of the sidebands-without-carrier side lobes relative to the centreline carrier-and-sidebands signal is such that it could cause 0.012 difference in depth of modulation if the side-lobe signal were reflected from an obstacle without relative loss to the centreline signal. In practice, it is most unlikely that such interference would reach the limit of 0.005 difference in depth of modulation since it is reasonable to assume 10 decibels of suppression on reflection. However, to ensure that this limit is not exceeded by reflection of

any part of the main lobes of the sidebands-without-carrier signal demands that there should be no large reflecting areas within a sector of ± 12 degrees originating at the localizer and extending at least the entire length of the runway.

The clearance aerial operates in a similar manner, but is a simple array of 3 dipoles, radiating omni-directionally. The carrier-and-sidebands signal goes to the centre dipole while the sidebands-without-carrier signal goes in antiphase to the outer dipoles. The resulting radiation is the familiar two overlapping kidney-shaped patterns.

The ratio of course signal to clearance signal is adjusted to be 10 decibels on the course line whereby equal levels occur at ± 8 degrees in azimuth. The high rate of change of the signal ratio about this angle ensures that when the aircraft passes from one field environment to the other, the receiver is assured of good capture effect in which the stronger signal suppresses the modulation on the weaker signal.

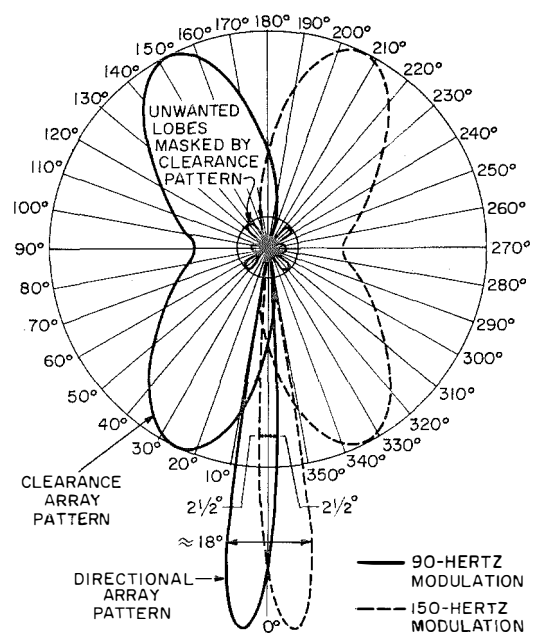

Figure 3—Course and clearance radiations of localizer.

The clearance radiation protects against false course indications produced by the side lobes of the main highly directive aerial. This provides all-round guidance to the accurate front course and also produces a back course, albeit of opposite sensing.

Figure 3 is a polar diagram of both the course and clearance radiation patterns.

3.6 LOCALIZER IMPROVEMENTS

Certain major improvements have been effected to the localizer for reducing the risk of interference by signal reflection from site obstacles and overflying aircraft.

3.6.1 Corner Reflector

With the normal aerial, already described, having dipoles 1 wavelength above ground, the radiation pattern in the vertical plane consists of two lobes as shown by the broken lines in

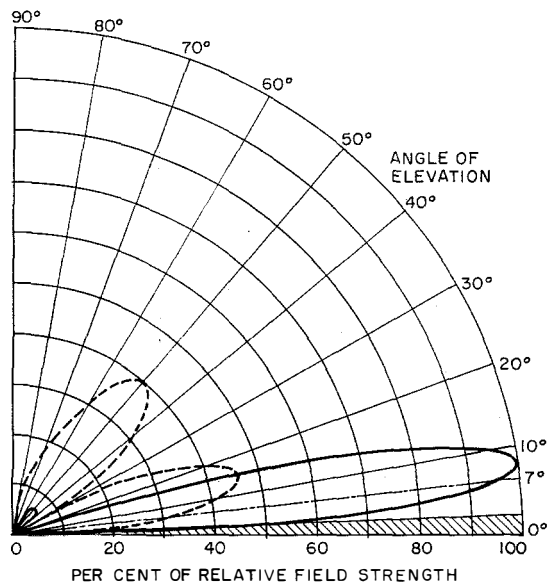

Figure 4—Vertical field pattern of localizer course array. The broken-line pattern is obtained without the corner reflector. The limit of elevation coverage required by the International Civil Aviation Organization is 7 degrees. The typical usable sector is shown shaded.

Figure 4. Most of the signal energy is radiated outside the usable sector, and a stronger signal may be incident on an overflying (reflecting) aircraft than that received directly by an aircraft approaching to land.

A 60-degree vertical-plane corner reflector is added to the aerial to enclose the array of dipoles. This prevents radiation at elevation angles greater than 30 degrees except for a small spill-over from the aperture edge and concentrates most of the energy in one lobe as shown in Figure 4. It can be seen that the peak of the lobe is increased by some 6 decibels in amplitude while also being lowered in elevation to about 9 degrees. As a result the relative signal level received by the landing aircraft is increased by 10 decibels for the same transmitted power.

The reduction in the risk of reflection from overflying aircraft is of the order of 20 decibels. The overall height of the aerial is increased to 18 feet (5.5 metres), which requires that it be located 300 feet farther from the end of the runway than before to conform to the requirements for obstacle clearance.

3.6.2 Double-Aperture Array

By approximately doubling the aperture to 165 feet (50 metres) and employing 24 dipoles, the main-course beam width is reduced to ± 6 degrees to zero signal. The signal level is increased by 3 decibels, while the relative amplitudes of the side lobes remain as previously. This is considered to be optimum beam sharpness consistent with maintaining the required linear structure of difference in depth of modulation out to ± 4 degrees. With the sensitivity set to give 0.155 difference in depth of modulation at ± 2 degrees, the measured value at ± 4 degrees is 0.304 difference in depth of modulation. Course-to-clearance cross-over is set to occur also at ± 4 degrees.

Low-Approach System for All-Weather Landings

3.6.3 *Combined Course and Clearance*

Discussions at the 7th session of the COM Division of the International Civil Aviation Organization have indicated that in the future positive guidance information would be required only within a limited front sector, and that "Information from some suitably located navigation aid together with appropriate procedures will generally be required to ensure that any misleading guidance information outside the sector is not operationally significant."

Accordingly the clearance radiation may also be directive, the signals being radiated from the same dipoles as the course signals. This is accomplished by combining both signals in a bridge for each dipole required to radiate both signals.

The separate clearance array and its ground space are saved, and by choosing the number of dipoles used and grading their signals the radiated clearance pattern may be shaped to desired characteristics. The first zero of signal occurs at ± 41.8 degrees, permitting adequate signal coverage out to the limit of ± 35 degrees set by the International Civil Aviation Organization.

The clearance has the same vertical radiation pattern and the same suppression of high-angle radiation as the course, both systems radiating from a common centre. A further advantage is that the transmitter building located behind the array screen is outside the fields of both systems.

3.6.4 *Quadrature-Phased Clearance*

Quadrature-phased clearance, which is applicable to both localizer and glide-slope transmission, simplifies the transmitter equipment and thus contributes to reliability. The quadrature-phased 90-hertz and 150-hertz sidebands, normally produced but wasted in the constant-impedance modulator, are used to serve the clearance transmission that necessarily shares a common carrier with the course transmission. To this end a power divider is included in the

carrier path immediately following the modulation-depth-control power divider, thus forming course and clearance channels from the common radio-frequency source. By this means the clearance transmission has the same high precision and stability as the course transmission, and the tone modulations are locked in frequency and in relative audio-frequency phase.

With adequate carrier amplitude ratio given to the two transmissions, the audio-frequency quadrature-phase relationship provides for similar capture effect in the aircraft receiver handling the combined signals as with the clearance system operating on a carrier of slightly different frequency from the course. A further measure of isolation is provided by displacing the common frequency carriers in phase quadrature.

Figure 5 shows an improved aerial array.

3.7 GLIDE-SLOPE AERIALS

The glide-slope aerial systems in general use are image arrays comprising two or more antennas spaced vertically in linear array above ground. The beam foundation depends on coherent signal reflection from the ground, requiring a considerable area of smooth level terrain fronting the array. The glide-slope characteristics may therefore be affected by changing level and conductivity of the ground from snow, rain, vegetation, et cetera, in the formative ground area; they are also susceptible to interference by extraneous signal reflections from ground irregularities and obstacles beyond the formative area.

The glide-slope system uses the first one or two lobes above the horizontal of the multilobular radiation pattern set up in the vertical plane by an antenna located above the reflecting ground plane. The elevation angles at which peaks and nulls of the signal occur are determined by the height of the antenna. Since the useful elevation sector extends up only to 7 degrees, the major portion of the radiated energy is wasted in higher-angle lobes. Because

of the cyclic reversals of phase, these lobes produce false courses and are also a potential source of interference by reflection.

Basically two types of aerial systems have been used, defined by their modes of operation as equisignal and null-reference.

3.7.1 Equisignal System

The equisignal mode of operation employs two antennas each radiating the carrier at different amplitudes, one modulated at 90 hertz and the other at 150 hertz.

The glide slope is formed at the equisignal crossover point of the first lobes of the two antennas. The upper antenna may be 3 to 5 times higher than the lower one and the structure of difference in depth of modulation is asymmetric above and below the glide slope. To achieve the required 40-per-cent modulation depth due to each tone on the glide slope, each carrier must be modulated to a depth of 80 per cent. The individual signals radiated therefore present a high potential interference risk to the

glide slope by non-coherent reflection. The overall height of the array is lower than in other systems and requires correspondingly less extent of formative ground, but the close proximity to the ground of the lower antenna renders the glide slope very sensitive to ground changes.

3.7.2 Null-Reference System

The basic null-reference mode of operation employs two antennas to give a symmetric lobe relationship, with one antenna twice as high as the other. The lower (reference) antenna radiates carrier-and-sidebands signal, the angle of peak signal of its first lobe being set at the glide-slope angle. The upper (null) antenna radiates sidebands-without-carrier signal, the null of signal between its first and second lobes forming the glide slope where there is no difference in depth of modulation. The resulting structure of difference in depth of modulation above and below the glide slope is perfectly symmetric and extremely linear over the sector width.

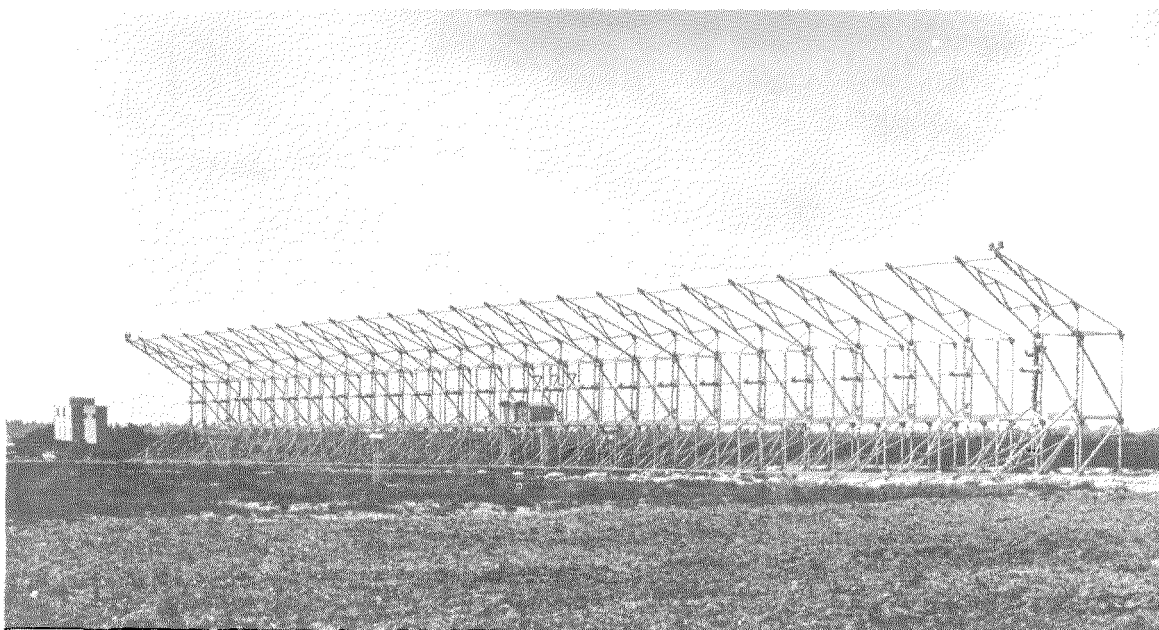

Figure 5—This experimental array of double aperture with corner reflectors improves performance.

Low-Approach System for All-Weather Landings

Only the sidebands-without-carrier signal is capable of deflecting the glide slope, and since the signal amplitude of the sidebands on the null antenna would cause modulation of only 14 per cent by each tone on the peak carrier signal, the risk of interference by non-coherent reflection is less than in the equisignal system. While more frontal level terrain is necessary due to the greater height of the null antenna, the glide slope is affected only to a minor extent by large changes in ground level from snow.

The null-reference array is therefore generally preferred for most sites. The vertical radiation patterns are shown in Figure 6 for the individual reference and null antennas, together with their sum patterns. These show the areas of predominance of each tone modulation over the other, plus the growth of difference in depth of modulation.

For the *STAN/8* array the antennas are wide-band horizontal half-wavelength dipoles, sup-

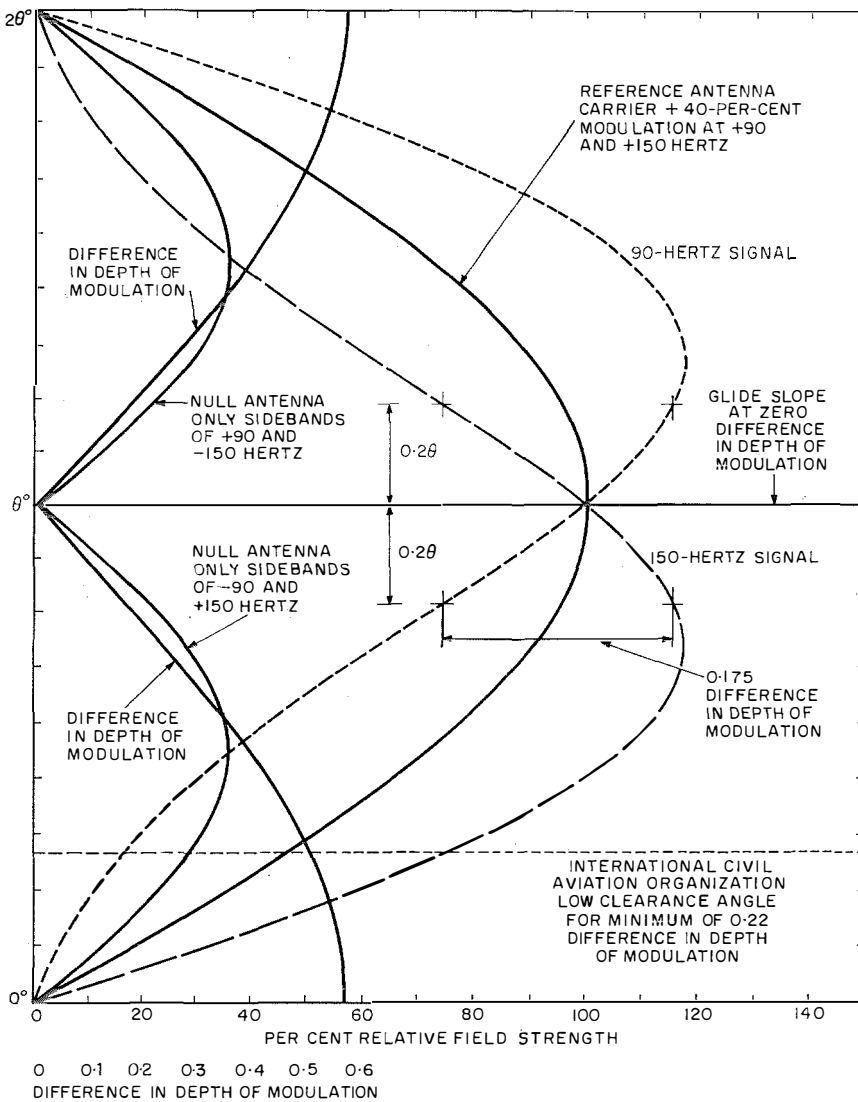

Figure 6—Vertical radiation patterns for null-reference glide slope. The amplitude of the sidebands-without-carrier signal is shown 2.5 times the actual value normalized to the 40-per-cent modulation level represented by the carrier-with-sidebands curve, which also indicates carrier level.

ported off a flat-plate reflector to give forward directivity and mounted up on a stayed mast.

The array is offset to one side of the runway near the approach end, and as a result the shape of the glide slope along the course line is hyperbolic, reaching its lowest level at the perpendicular to the array. The descent path, however, is substantially a straight line down to 50 feet (15 metres) above the runway threshold, and the subsequent flare aids the landing manoeuvre. To ensure phase coherence of the two antenna signals throughout the glide slope, one antenna is laterally displaced from the vertical centreline of the array.

An important requirement of the system is that a "fly-up" signal at full strength should be received by an aircraft for 10 nautical miles (18.5 kilometres) at the low-approach limit of 0.3θ . These high-deflection signals radiated at low elevation angles may be reflected destructively on to the glide slope from obstacles or rising ground near the course line.

To improve the glide-slope characteristics on difficult sites, various modified forms of the null-reference-mode image array have been developed [2, 3] chief among which are the sideband-reference array and the capture-effect array. The former, by reason of its lower antenna heights, is suited to those sites where the extent of smooth level terrain is inadequate for the null-reference array or where a valley may be illuminated by the null antenna.

Introduced more recently, the capture-effect array is suited particularly to sites where obstacles and rising ground exist in the approach region. A third antenna is added to the null-reference array at 3 times the height of the reference antenna. Both carrier-and-sidebands and sideband-without-carrier signals go to more than one antenna, at different amplitudes and polarities, whereby the sum of the radiated signal lobes of the fundamental, second, and third harmonics results in a desired shaping of these waveforms that reduces their signal levels severely at low elevation angles.

Adequate fly-up signal is restored at low angles by a second clearance transmission radiated from the same antennas; the two sets of signals are combined in bridge networks in the signal distribution equipment. As for the localizer, the quadrature-phased clearance system may be employed, derived simply from the *STAN/8* type of transmitter equipment without requiring different carrier- and tone-modulation sources.

For all these arrays improved higher-gain antennas, giving more directivity both in elevation and azimuth, confine more of the radiation to the usable volume of air space. By reducing the power demand, they permit the use of solid-state devices throughout the transmitter equipment, with consequent improvement in reliability of service.

Other types of aerial have been developed which form the glide-slope beam substantially independent of the terrain [3]. A vertical broadside array of horizontal dipoles with aperture of 70 feet (21 metres) has been developed by ITT Federal Laboratories. The array is excited with carrier-and-sidebands and sidebands-without-carrier signals in a similar manner to the localizer array. It produces narrow main lobes of both signals, the total width of which to the first zeros is only twice the glide-slope angle. The array is tilted backward by the glide-slope angle so that the beam zero is at the horizontal, below which for some 8 degrees signal side lobes are suppressed to very-low amplitudes. Only these small signals therefore illuminate the near ground to affect the beam structure over the useful elevation sector.

By the use of such alternative glide-slope aerial systems to overcome the difficult terrain characteristics of a particular site, it is hoped to provide improved and reliable performance to satisfy the stringent requirements of automatically controlled low approach down to the level at which the accurate radio altimeter takes control.

4. Radio Altimeter

The radio altimeter is required as part of the system because the glide slope of the instrument low-approach system is not internationally approved for use in the final stages of descent to touch-down and because many systems require indication of progress along the approach for control and switching purposes. Some also require guidance signals during the last phase of approach and touch-down.

In modern all-weather approach and landing systems, the radio altimeter has two principal and separate roles: (*A*) as a decision height indicator for the pilot, and (*B*) as a height sensor in an automatic approach and landing system.

In the former application, the most important duty of the radio altimeter is to provide the pilot with a clear, unambiguous, and easily read indication of his height above the ground. Secondly, the altimeter may be connected into some other form of display, such as a paravision director, or it may be used in some other way as part of a flight-control system.

In the latter application, the prime value of the radio altimeter lies in the signals it supplies to the automatic flight-control system to guide aircraft in elevation down to touch-down. In this case the indication presented to the pilot is generally of secondary importance and is no more than confirmation that the system is working normally. The requirements of the radio altimeter will therefore be examined separately under these two headings.

4.1 LOW-APPROACH SYSTEMS, CATEGORIES I AND II

Since regulations of the International Civil Aviation Organization permit an aircraft to be certified for low approach to stipulated heights under bad weather conditions, it is necessary for the pilot to know when those minimum heights have been achieved. Since in operation under Category II this height is as low as 100 feet (30 metres), barometric altimeters cannot

be relied on to give a sufficiently accurate indication. On the other hand, the radio altimeter has the problem that it measures the distance to the terrain underneath; there is no guarantee that the terrain ahead of the runway will be sufficiently level to ensure that the height given is accurate enough with respect to the runway surface.

This problem can be overcome by a simple procedure. Since the contour of the terrain in front of the touch-down point and on the normal approach is known and is constant, corrections can be published to inform the pilot what his radio altimeter should read for the important altitudes. Thus, at some particular airfield, the pilot may be informed that he will be exactly 100 feet (30 metres) above the runway surface when his radio altimeter reads 90 feet (27 metres). This would appear to be a much more satisfactory arrangement than the continual re-setting of barometric altimeters which is now necessary.

The altitude range considered most satisfactory for present low-approach systems is 0 to 2500 feet (760 metres). However, good indicator readings are essential at the levels of 300, 200, and 100 feet (90, 60, and 30 metres). For this reason a linear display of altitude on the indicator is not satisfactory, and present practice is to use a non-linear scale in which the altitude indication is expanded between 0 and at least 300 feet (90 metres). This severely cramps the scale towards the 2500-foot (760-metre) end, and it is not clear exactly to what use this end of the scale will be put. In general, it seems that scale readings between 2500 and 400 feet (760 and 120 metres) will merely give the pilot confirmation that the radio altimeter is operating before he gets down to his decision height. Opinions vary widely as to the best form of the scale and at least 9 different scales are presently offered. The principal controversy is whether to expand the bottom end of the scale logarithmically or linearly between 0 and 500 feet (150 metres). Protagonists of the former system claim that it gives better readability of

the important spot heights. Advocates of the linear scale claim that when the aircraft is descending at a fixed rate, if the scale is logarithmic the needle will appear to accelerate as the aircraft descends, thus giving the pilot a false impression.

In a low-approach system, there is no requirement for failure survival in the electronic equipment, since if anything is wrong the pilot must pull up at or before his decision height and divert or go round again. Thus, the pilot must be warned with a high degree of reliability that something is wrong with his system; this usually dictates the use of two radio altimeters with a cross-comparison system or one radio altimeter with high-integrity monitoring.

There are certain systems that use only one radio altimeter in connection with an automatic landing technique, but these are really only low-approach with an automatic landing back-up that may be used under visual conditions.

For a low-approach system, the accuracy of the radio altimeter must be about ± 3 feet (1 metre) or ± 5 per cent, whichever is greater, and it must be reliable enough to avoid too many missed approaches.

4.2 AUTOMATIC LANDING

For automatic landing, the requirements of the radio altimeter system are somewhat different from those of the low-approach case. Firstly, for automatic landing in zero visibility (Category III), the altimeter system must have full failure survival. This dictates the use of either a triplicated cross-comparison system or a duplicated fully monitored system. In both cases, the altimeters have similar output characteristics and differ only in their method of failure survival.

For the automatic landing function, a radio altimeter must have somewhat greater accuracy below 200 feet (60 metres), and the accuracy at the moment of touch-down must not be worse than ± 1 foot (0.3 metre). The requirements for noise on the output signal of the radio

altimeter differ widely according to the type of system with which it is to be used.

In some systems, the radio altimeter is used only in a secondary loop to control the gain of some other part of the system, as for example the gain of the flare computer to the instrument landing glide-slope system.

In other systems, such as the Blind Landing Experimental Unit (*BLEU*) system, the radio altimeter is in direct control of the elevation guidance of the aircraft during flare. This involves the direct use in the flare computer of the height output, the rate of height, and in some cases the second derivative. It can be seen that in such a system the altimeter must provide noise-free height information.

4.3 PRESENT BRITISH PRACTICE

In the United Kingdom, the philosophy of using low-approach and automatic landing systems has been somewhat different from that in the rest of the world. The original task of the Blind Landing Experimental Unit was to produce an automatic landing system suitable for certain types of military aircraft. As these are not subject to regulations of the International Civil Aviation Organization, a simpler system could be envisaged than is presently required for civil airliners.* Although such a system would not have the reliability now required for use in passenger aircraft, it nevertheless increases significantly the chances of a returning military aircraft to land safely at its base instead of risking a diversionary manoeuvre with insufficient fuel left in its tanks to carry this out. Such a system has indeed been perfected by the Blind Landing Experimental Unit, and over 15 000 automatic landings have been made with it without incident.

* The first phase of the United Kingdom civil automatic landing programme came to fruition when, in June 1965, a Trident aircraft of British European Airways made the first ever automatic flare with paying passengers at London Airport. Two *STR 40* radio altimeters and the *STAN/7/8* instrument low-approach system provided the guidance.

When the necessity to improve the all-weather approach capabilities of the airlines of the United Kingdom was studied, it was only natural that the Blind Landing Experimental Unit system be considered to see how near it would come to meeting the airline requirements.

After a good deal of study, it was decided that the most promising line of attack was to go directly to a system that had automatic landing capability as a first means of achieving Category II operation. The system would also be capable of extension to full Category III operation for automatic landing in zero visibility. For reasons now well known, changes in technique for the azimuth guidance of the aircraft have been modified for the civil case. However, the elevation guidance system now being implemented on United Kingdom civil aircraft is almost exactly the same as that devised by the Blind Landing Experimental Unit for its original military system.

The Blind Landing Experimental Unit concepts of automatic landing have directly influenced the working characteristics and altitude range of radio altimeters presently used in British military and civil aircraft. In particular, a maximum scale of 500 feet (150 metres) with a "hold-off" altitude of 1000 feet (300 metres) is stipulated. This means that the altitude range from zero to 500 feet (150 metres) is spread around the full scale of the indicator; the hold-off requirement means that the needle of the indicator must remain above scale up to at least 1000 feet (300 metres). In addition, the Blind Landing Experimental Unit specifies an in-flight or confidence check method that will enable the pilot to ensure that the radio altimeter will work properly at the beginning of flare; this check can be made at any altitude.

Thus, there is a certain equivalence between the *ARINC 552* specification calling for maximum altitude of 2500 feet (750 metres) and the Blind Landing Experimental Unit philosophy of a maximum altitude of 500 feet (150 metres) plus a confidence check.

It is interesting that the *ARINC 552* specification takes cognizance of the importance of this latter region by stipulating an output characteristic from the radio altimeter that is linear between 0 and 500 feet (150 metres) and provides nearly half the total output within this region. As a result, the *ARINC* output characteristic cannot be displayed with any great use directly on a linear indicator, since the part of the scale from 0 to 500 feet (150 metres) would be too cramped, and the output characteristic must be modified further in the indicating instrument to provide a useful scale shape. However, the intention here was to provide an output characteristic that showed a reasonable slope of volts per foot of altitude to operate automatic flight control systems, and it is evidently considered that the cost of re-shaping the characteristic in the indicator to provide a usable scale shape is thereby counter-balanced.

4.4 FUTURE TRENDS IN DESIGN

For some time radio altimeters, having an accuracy of ± 3 per cent and a touch-down accuracy of ± 1 foot (0.3 metre), have been used in a variety of different systems. It is now fairly evident that these orders of accuracy are sufficient for all the known systems. It is not clear what advantages would be gained from increasing the accuracy of radio altimeters for low-approach and landing systems by anything like an order of magnitude. The very nature of the terrain over which they pass, and even the irregularities of the runways on which the aircraft land, probably would be comparable with any such increased accuracy.

It seems likely, therefore, that future trends in radio-altimeter design will be directed towards channels other than those of increased accuracy. The most obvious direction of approach is towards increased reliability of operation. This implies not only an improvement in the number of hours for which an equipment will work before it goes un-serviceable, but also reliability of operation in any environment. By this is meant not only resistance to the normal aircraft

environments of vibration and temperature, but also those environments of electrical noise and interference generated inside or outside the aircraft.

The present approach to improving reliability of operation from the point of view of longer mean-time-between-failures is to improve the design by the use of better components and circuit elements. In particular, the availability of microwave solid-state devices and monolithic integrated circuits has perhaps had the major impact on modern radio-altimeter design. The most popular frequency band allocated for radio altimeters is 4200 to 4400 megahertz, and it is now possible to construct reliable all-solid-state transmitters for operation in this band. In this context the frequency-modulated continuous-wave radio altimeter has an advantage over the pulse type in that a continuous-wave output of the order of 0.5 watt is now feasible, which is adequate for this type of operation. On the other hand, pulse altimeters must use a higher peak output to achieve the same range, and this is presently beyond the state of the microwave semiconductor art.

In the case of the video-frequency circuits, the advances of the past few years in analogue integrated circuits have made it possible to engineer an advanced signal processing system. There are several approaches to increasing the immunity of a radio altimeter to the effects of natural and artificial noise. At the moment, narrow-band systems that give greater preference to the wanted signal than to the interfering noise are of primary interest. Indeed, it is possible to vary the bandwidth with altitude in such a way that just enough bandwidth is available to receive the wanted signal under any conditions. In this context the frequency-modulated altimeter has an advantage over the pulse type because of the following considerations.

A pulse altimeter measures altitude by determining very accurately the time difference between the leading edges of two pulses. The nearer the ground the more accurate must this measurement be, and at touch-down the ac-

curacy must be of the order of 1 or 2 nanoseconds to achieve an accuracy of 1 foot (0.3 metre). This capability requires a larger bandwidth near touch-down than at higher altitudes.

The frequency-modulated continuous-wave altimeter, on the other hand, employs a video-frequency signal the frequency of which decreases as touch-down is approached. Thus the video bandwidth may be progressively reduced toward touch-down, giving maximum protection against outside interference signals at the vital point.

There can be no doubt that the future will bring radically new principles in radio altimetry, but it seems likely that for the next decade all radio altimeters in practical systems will be of one of these two types.

4.5 FUTURE USE

It is certain that the future will see entirely new forms of automatic landing for aircraft, and indeed such systems are already under development.

However, for the guidance of aircraft during the last phase of approach and landing, the low-level high-accuracy radio altimeter has so much to offer that it will not be supplanted by any other form of height sensor for a long time. In particular, its basic simplicity and its freedom from the vagaries of propagation exhibited by other very-high-frequency and microwave systems are strong points in its favour. Concerning the latter point, it always uses the shortest propagation path to make the necessary measurement and it uses this path to give the necessary information in the most direct way. It therefore has considerable advantages over other systems that work on angular measurement principles and must use much longer paths and small angular measurements near the ground. They thus expose themselves to the danger of variation in the propagation path and possibly reflections from unwanted obstacles.

5. Appendix

5.1 90-HERTZ AND 150-HERTZ MODULATIONS

The heart of the *STAN/7/8* equipment is the mechanical modulator that produces the 90-hertz and 150-hertz sidebands with their special relationship so as to produce the carrier-and-sidebands and sidebands-without-carrier signals.

Pure amplitude-modulated sidebands are generated in a balanced low-*Q* circuit in a manner that preserves the input impedance constant. The sidebands are produced by a mechanical modulator, and both tones owe allegiance to a common 30-revolution-per-second drive shaft of a speed-controlled motor.

The basic circuit for one tone is shown in Figure 7. The differential capacitors are formed by rotor vanes driven by the common drive shaft. A 3-bladed vane produces the 90-hertz modulation and a 5-bladed vane produces 150 hertz. For each tone two equal outputs are produced in audio-frequency phase quadrature, and the two sets of differential capacitors are correspondingly angularly spaced on the shaft. There is thus a constant load on the input with no impedance variation over the modulation cycle. Only one audio-frequency-phased output is used in the *STAN/7/8* equipment; the other is dissipated in a load resistance.

Figure 8 shows the basic radio-frequency transmission circuit. The radio-frequency output from the crystal-controlled drive source is taken through a low-pass filter to a power-dividing bridge circuit. One output of this bridge becomes the carrier while the other output is passed to the modulators via another power-dividing bridge. The first power control thus determines the depth of modulation and the second permits exact balancing of the two tone modulations, the two controls being independent of each other.

The 90-hertz and 150-hertz sideband outputs from the modulators are combined in a bridge that isolates the two modulators from each other. One combined output is subsequently combined in another bridge with a carrier in

the correct proportion for the desired depth of modulation, thus forming the carrier-and-sidebands output. The second similar combined-sidebands output, in which those of one tone are phase reversed, is passed through an amplitude control (determining the course sector width) and a phaser and is the sidebands-without-carrier output.

The characteristics of the transmission and the particular advantages of this type of modulator follow.

(A) Pure amplitude-modulated sidebands are generated without accompanying phase or frequency modulation, and the waveform is determined by the mechanical shaping and relative orientation of the capacitor blades. Intermodulation products are minimal and exist only because of small impedance irregularities in cables and connectors. No intermodulation component exceeds 2 per cent of the amplitude of the equal fundamental tones. Harmonic distortion is less than 5 per cent root-mean-square.

(B) The tone frequencies are held constant by the motor speed control to extremely close tolerance (less than 0.1 per cent), and transmission ceases if the frequencies deviate by more than 1 per cent. This helps minimize difference in depth of modulation error caused by the 90- and 150-hertz filter response in the aircraft receivers as well as in the ground monitors.

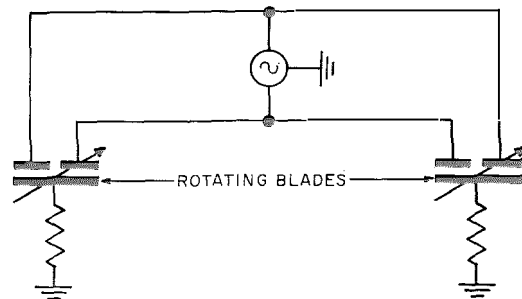

Figure 7—Basic circuit for 1 tone. There are 2 sets of rotating blades in audio-frequency phase quadrature for each tone to keep the impedance constant over the modulation cycle. One output is dissipated in a resistor as it is not needed.

(C) The relative audio phase of the two tones is locked and set within ± 3 degrees of phase, referred to 150 hertz, of a preferred relationship. In the localizer, which transmits the course from a highly directive aerial and the clearance omni-directionally, both sets of modulators are driven from the common shaft, and the audio-frequency phase relationship is set within ± 5 degrees to ensure proper difference in depth of modulation in the combined field.

(D) Each modulator requires only two adjustments for initial alignment (input tuning and coupling), and both adjustments are made to the lowest reading of a reflectometer. The operation takes only a few seconds to perform, whereupon the controls are locked and require no further adjustment.

(E) A non-metallic shaft is used within the modulator, and bearings are shielded and contained within earthed planes. Since the device produces sidebands, it handles only a fraction of the total radio-frequency power so that radio-frequency currents due to unbalance in the circuit are minute.

(F) The method of achieving amplitude control by power division in a bridge provides an extremely sensitive and smooth adjustment for the important controls of modulation depth, balance of tones, and course sector width.

The setting accuracies in the localizer are within 0.05 per cent in modulation depth, 0.03 per cent in difference in depth of modulation, in balance of tones, and in sector width, and 0.1 degree in radio-frequency phase between carrier and sidebands.

(G) The carrier frequency is constant within ± 10 parts in a million. The low-pass filter in the transmitter output provides at least 40 decibels of extra attenuation at the 2nd harmonic and higher frequencies up to at least the 6th harmonic.

Radio-frequency phase variation in both the carrier-and-sidebands and the sidebands-without-carrier paths is kept to a minimum by ensuring a low voltage standing-wave ratio and by the use of exceptionally stable coaxial cable. Differential phase shift is kept negligibly low by ensuring the same total path lengths for both types of signal. All cable lengths are accurately determined to within ± 0.3 degree by means of a phase comparator at the mid-band frequency.

(H) Solid-state devices are used throughout the equipment except for the radio-frequency drive unit, which used 4 tubes in each working channel of the localizer and 6 in the glide-slope equipment. More-recent improvements to aerials providing greater gain, together with

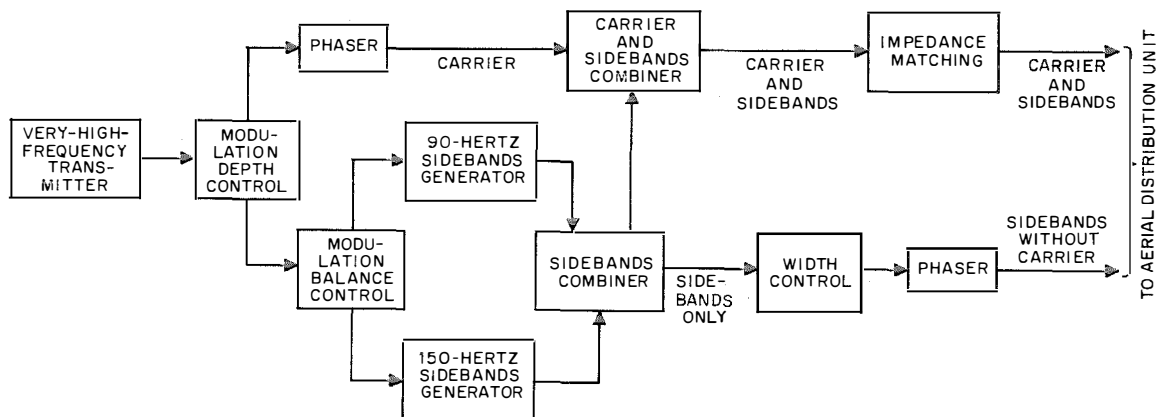

Figure 8—Basic transmission circuit.

Low-Approach System for All-Weather Landings

higher-power solid-state devices for use at higher frequencies, now make possible the complete elimination of tubes with the enhanced reliability.

6. References

1. R. A. Hampshire, "Fixed-Beam Aircraft Approach System," *Electrical Communication*, volume 31, number 3, pages 189-197; September 1954.
2. F. W. Iden, "Glide-Slope Antenna Arrays for Use Under Adverse Siting Conditions," *IRE Transactions on Aeronautical and Navigational Electronics*, volume ANE-6, number 2, pages 100-111; June 1959.
3. "Analysis of I.L.S. Glide-Slope Antennas in Operation and Under Development," Report Number RD-64-11, prepared by the National Engineering Science Company for the Federal

Aviation Agency, Systems Research and Development Service; February 1964.

4. D. L. Cooper-Jones, "A High-Accuracy Instrument Landing System," *World Aviation Electronics*, volume 2, number 4, pages 157-167; April 1962.
5. F. H. Taylor, F. T. Norbury, and F. G. Fernau, "The STAN.7 Directional Localizer," Working Paper Number 22 on All-Weather Landing and Take-Off, 15th Technical Conference of the International Air Transport Association; April 1963.
6. F. R. Gill, M. E. Smith, and J. D. Asteraki, "An Experimental Assessment of the Stability of the Course Line of an I.L.S. Localizer Ground Equipment," Conference on Electronics Research and Development for Civil Aviation organized by the Electronics Division, Institution of Electrical Engineers, London; 2-4 October 1963. Presented under Session 2, "Aids to Approach and Landing."

William L. Garfield was born in 1916 and received his education at St. Paul's School of London and Northampton Polytechnic. He was initially trained as a classics scholar, but a keen early interest in engineering caused him to join Standard Telephones and Cables in 1940 as a junior member of the engineering inspection department.

Mr. Garfield is now chief engineer of the Navigational Systems Group in the Radio Division. He has many patents and has contributed many articles to the technical press.

F. T. Norbury was born in London, England, on 4 December 1906. He received the Higher National Certificate in Electrical Engineering, with distinction in Electrical Technology, from the Borough Polytechnic, London, in 1930.

He joined Standard Telephones and Cables in 1928 and has been with the Radio Division until the present time, being engaged until 1957 in the design and development of high-power broadcast transmitters. In 1957 he transferred to the Navigational Aids Section to coordinate the design and development of instrument landing systems.

Mr. Norbury is an Associate Member of the Institution of Electrical Engineers.

Modulation, Noise, and Spectral Analysis

Philip F. Panter of ITT Federal Laboratories is the author of a recently published book on Modulation, Noise, and Spectral Analysis. It is based on courses he has given at ITT Federal Laboratories and at the graduate school of Newark College of Engineering. Its 24 chapters are on the following subjects.

1. Methods of Modulation and Evolution of Modulation Systems
2. Mathematical Background: Review of Fourier Series and Fourier Transform
3. Signal Transmission Through Linear Systems
4. Mathematical Background: Random Signal Theory—Application to Noise Problems
5. Linear Modulation Systems
6. Linear Demodulation or Detection
7. Exponential Modulation: Basic Principles and Spectral Distribution
8. Distortion of Frequency-Modulated Signals Through Linear Systems: Fourier Method
9. Distortion of Frequency-Modulated Signals Through Linear Systems: Dynamic or Asymptotic Method
10. Transient Response in Frequency Modulation
11. Interference in Frequency-Modulation Reception: Common- and Adjacent-Channel Interference and Multipath Transmission
12. Generation of Frequency-Modulated Signals
13. Detection of Frequency-Modulated Signals
14. Signal-to-Noise Improvement in Frequency-Modulation Systems
15. Application of Negative Feedback to Frequency-Modulation Systems
16. Threshold Extension in Frequency-Modulation Receivers
17. Sampling Principle and Introduction to Pulse Modulation
18. Time-Division Multiplex Systems
19. Introduction to Information Theory—With Special Applications to Pulse-Code Modulation
20. Principles of Pulse-Code Modulation
21. Output Signal-to-Noise Improvement Ratio in Pulse-Code Modulation Systems
22. Delta Modulation
23. Digital Data Modulation Systems
24. Comparable Analysis of Modulation Systems

The book is 6 by 9 inches (15 by 23 centimeters) and contains 750 pages of text and 9 pages of index. It is published by McGraw-Hill Book Company, 330 West 42 Street, New York, New York 10036. The price is \$19.50.

Mathematik für Elektrotechniker (Mathematics for Electrical Engineers)

Dr. phil. Viktor Fetzler of Standard Elektrik Lorenz has written this book for both students and those working in the field of electrical engineering. Beginning with arithmetic, the book deals with such subjects as complex numbers, theory of loci, theory of functions, algebra, exponential series, differential calculus, and integrals.

This book is 17 by 23 centimeters (6.7 by 9 inches) and contains 246 pages with 83 illustrations. It includes both a list of references and an index. Dr. Alfred Hüthig Verlag of Heidelberg is the publisher and the price is DM 21.80.

World's Telephones—1965*

More telephones were added to the worldwide communications network in 1964 than in any other year in history. The gain of 11 500 000—a 6.7 percent increase over the previous year—raised the total to 182 500 000 on 1 January 1965.

As its telephones became more numerous, the world moved closer to the day when calling anyone, anywhere, will be as simple as calling the next town. The telephone user in the United States can now reach 97 percent of the world's telephones, with many of the overseas

calls going through fast with the outgoing operator dialing the distant telephone. Helping pave the way to worldwide direct dialing was the conversion to an all-number calling basis of the city of Paris, and the British Post Office decision to convert telephone service in the United Kingdom to all-number calling over the next three years. All-number calling is a key factor in the international dial program.

During the year, telephone connections were established for the first time between the United States and the Cook Islands in the Pacific, and between the United States and Liberia. Outgoing operator dialing was available to the following countries: Australia, Belgium, Bermuda, the Federal Republic of Germany (West Germany), Italy, Jamaica,

* Abridgement from the 1965 issue of a booklet, "The World's Telephones," published yearly by the chief statistician's office of the American Telephone and Telegraph Company, New York, New York.

TABLE 1
TELEPHONES IN CONTINENTAL AREAS—1 JANUARY 1965

Area	Number in Service			Privately Operated (1)		Automatic	
	Number 1965	Percent of World	Per 100 Population	Number 1965	Percent of Total	Number 1965	Percent of Total
North America	95 502 500	52.3	45.0	94 281 700	98.7	94 506 000	99.0
Middle America	1 499 900	0.8	2.0	1 068 300	71.2	1 332 600	88.8
South America	4 072 300	2.2	2.5	1 964 600	48.2	3 580 500	87.9
Europe	57 417 900	31.5	9.2	10 130 900	17.6	51 392 100	89.5
Africa	2 359 700	1.3	0.8	21 300	0.9	1 804 100	76.5
Asia (2)	17 601 700	9.7	1.0	11 566 200	65.7	12 038 300	68.4
Oceania	4 046 000	2.2	22.9	304 100	7.5	3 346 000	82.7
World	182 500 000	100.0	5.6	119 337 100	65.4	167 999 600	92.1

(1) Necessarily the distinction in this classification is with respect to operation rather than ownership. In particular it is to be noted that systems that are government owned in whole or in part may be privately operated, as in Italy and Japan. The word "government" refers to nations, states, or municipalities.

(2) These data include allowances for the Asiatic parts of Turkey and the Union of Soviet Socialist Republics.

Japan, Netherlands, Puerto Rico, Switzerland, United Kingdom, and Virgin Islands. A new transatlantic cable, the fourth for the Bell System, was put into operation in September 1965. Two other cable links began operating in December 1964, one of them between Florida and St. Thomas in the Virgin Islands, and the other between Guam and the Philippine Islands.

Satellite communications took a stride forward with the June 1965 launching of Comsat's EARLY BIRD, the latest version of space communications. Satellites will supplement cables in meeting the rapidly growing demand for worldwide telephone calling. Calls overseas from the United States rose from 5 300 000 in 1964 to a new high this year of 6 400 000, a gain of about 20 percent.

The year 1964 ended a decade during which the world's telephones almost doubled in number. North America alone, with 95 502 500, has as many telephones today as all the world

in 1955. Most of the North American total is in the United States, with 88 785 000 telephones at the beginning of 1965. The gain for the year was 4 332 000. Other countries, however, continue to grow at an even faster relative rate.

Japan, which moved into second place in the 1963 tabulations, held that position in 1964 as it continued its rapid telephone growth, with the addition of 1 568 300 telephones (an increase of 14.7 percent). Its present count of 12 251 000 is 332 percent more than it had ten years ago.

The United Kingdom, with 9 960 000 and the Federal Republic of Germany (West Germany), with 8 168 000, are third and fourth, respectively. Rounding out the list of the ten countries having the most telephones are Union of Soviet Socialist Republics, with 7 200 000 (estimated); Canada, with 7 021 000; France, 5 704 000; Italy, 5 529 000; Sweden, 3 387 000, and Australia, 2 670 000.

TABLE 2
TOTAL NUMBER OF TELEPHONES IN SERVICE

Area	1964	1963	1962	1961	1960	1955
North America	90 831 400	87 029 400	83 186 400	79 830 600	76 036 400	56 691 700
Middle America	1 389 000	1 275 800	1 167 300	1 075 900	1 008 000	700 300
South America	3 872 800	3 732 600	3 475 500	3 337 600	3 145 900	2 422 900
Europe	53 377 600	49 734 800	46 377 000	43 172 700	40 340 900	27 787 000
Africa	2 241 500	2 155 100	2 081 800	2 005 300	1 904 500	1 247 400
Asia (1)	15 475 400	13 577 200	11 903 300	10 353 400	9 110 000	4 261 200
Oceania	3 812 300	3 595 100	3 408 700	3 224 500	3 054 300	2 189 500
World	171 000 000	161 100 000	151 600 000	143 000 000	134 600 000	95 300 000

(1) These data include allowances for the Asiatic parts of Turkey and the Union of Soviet Socialist Republics.

TABLE 3
TELEPHONES BY COUNTRIES AS OF JANUARY 1 1965

Area	Number of Telephones	Per 100 Population	Percent Automatic	Telephones by Type of Operation (1)	
				Private	Government
NORTH AMERICA					
Canada	7 021 000	36.12	94.8	5 871 725	1 149 275
Greenland	0	—	—	—	—
St. Pierre and Miquelon	527	10.54	0.0	0	527
United States (2)	88 481 000	45.88	99.3	88 410 000	71 000
MIDDLE AMERICA					
Bahama Islands	18 817	13.84	98.6	2 330	16 487
Barbados	13 945	5.69	100.0	13 945	0
Bermuda (3)	19 852	40.51	100.0	19 852	0
British Honduras	1 184	1.14	80.2	959	225
Canal Zone (3, 4)	9 385	22.19	100.0	0	9 385
Cayman Islands	32	0.36	0.0	0	32
Costa Rica	21 559	1.53	85.0	730	20 829
Cuba	228 687	3.08	93.2	0	228 687
Dominican Republic	30 375	0.87	94.6	29 925	450
El Salvador*	22 000	0.77	50.0	0	22 000
Guadeloupe	5 958	1.92	29.4	0	5 958
Guatemala	23 370	0.55	92.8	0	23 370
Haiti	4 400	0.10	86.0	0	4 400
Honduras	8 931	0.42	94.0	0	8 931
Jamaica	45 794	2.62	100.0	45 794	0
Leeward Islands:					
Antigua	1 184	1.88	0.0	0	1 184
Montserrat*	275	2.12	0.0	0	275
St. Kitts	765	1.23	75.8	0	765
Total	2 224	1.61	26.1	0	2 224
Martinique	9 116	2.87	73.9	0	9 116
México	725 072	1.80	85.2	723 759	1 313
Netherlands Antilles	19 890	9.66	100.0	5 768	14 122
Nicaragua	12 021	0.74	74.3	0	12 021
Panamá	41 658	3.40	98.3	40 968	690
Puerto Rico	186 948	7.20	96.5	174 930	12 018
Trinidad and Tobago	36 614	3.79	87.5	0	36 614
Turks and Caicos Islands	130	2.17	65.4	85	45
Virgin Islands (United Kingdom)	74	0.93	0.0	0	74
Virgin Islands (United States)	7 405	17.63	100.0	7 405	0
Windward Islands:					
Dominica	830	1.28	0.0	0	830
Grenada	1 831	1.95	100.0	1 831	0
St. Lucia	1 016	1.08	65.8	0	1 016
St. Vincent	550	0.64	0.0	0	550
Total	4 227	1.25	59.1	1 831	2 396
SOUTH AMERICA					
Argentina	1 472 132	6.64	89.2	1 066 871	1 365 261
Bolivia*	20 000	0.54	92.0	12 000	8 000
Brazil	1 263 072	1.60	83.0	1 197 392	65 680
British Guiana	9 871	1.55	91.8	0	9 871
Chile	249 582	2.89	84.7	247 932	1 650
Colombia	409 589	2.63	96.4	7 777	401 812
Ecuador	43 499	0.88	99.1	0	43 499
Falkland Islands and Dependencies*	460	23.00	0.0	0	460
French Guiana	1 440	4.00	0.0	0	1 440
Paraguay	13 566	0.69	92.0	0	13 566
Peru	132 367	1.15	87.5	132 367	0
Surinam	7 040	1.93	98.4	0	7 040
Uruguay*	189 500	7.02	82.0	0	189 500
Venezuela	260 228	3.04	96.8	260 228	0

* Estimated.

- (1) Necessarily the distinction in this classification is with respect to operation rather than ownership. In particular it is to be noted that systems that are government owned in whole or in part may be privately operated, as in Italy and Japan. The word "government" refers to nations, states, or municipalities.
- (2) Data for the State of Alaska are included. Data for the State of Hawaii are included under Oceania, rather than here under North America. About two-thirds of the estimated number of governmentally operated telephones are in the State of Alaska.

- (3) Data exclude telephone systems of the armed forces.
- (4) Data are as of 30 June 1964.
- (5) Data are as of 31 March 1965.
- (6) Includes the Federation of South Arabia.
- (7) Data for China (Mainland) are as of 1 January 1948. Those parts of the telephone system which are shown in the table as privately operated continued under such operation until 1949, when they came under government operation.
- (8) Data are as of 30 September 1964.

TABLE 3—Continued
TELEPHONES BY COUNTRIES AS OF 1 JANUARY 1965

Area	Number of Telephones	Per 100 Population	Percent Automatic	Telephones by Type of Operation (1)	
				Private	Government
EUROPE					
Albania*	6 000	0.33	50.0	0	6 000
Andorra*	700	6.36	0.0	0	700
Austria	936 207	12.99	94.7	0	936 207
Belgium	1 468 144	15.57	94.5	0	1 468 144
Bulgaria	248 900	3.04	58.9	0	248 900
Channel Islands:					
Guernsey and Dependencies	15 406	32.71	53.2	0	15 406
Jersey	22 046	34.99	63.7	0	22 046
Total	37 452	34.05	59.4	0	37 452
Czechoslovakia	1 398 509	9.91	87.4	0	1 398 509
Denmark	1 310 746	27.46	67.0	1 160 635	150 111
Finland	778 101	16.92	87.5	548 987	229 114
France	5 703 878	11.71	84.8	0	5 703 878
Germany, Eastern	1 586 838	9.33	99.0	0	1 586 838
Germany, Federal Republic	8 168 188	13.93	99.9	0	8 168 188
Gibraltar (3)	4 436	18.48	100.0	0	4 436
Greece	431 292	5.06	95.2	0	431 292
Hungary	538 608	5.31	73.7	0	538 608
Iceland	52 368	27.56	78.0	0	52 368
Ireland	203 900	7.14	72.9	0	203 900
Italy	5 528 751	10.54	97.4	5 528 751	0
Liechtenstein	6 073	31.96	100.0	0	6 073
Luxembourg	74 010	22.43	100.0	0	74 010
Malta (5)	21 989	6.89	93.5	0	21 989
Monaco*	10 600	46.09	100.0	0	10 600
Netherlands	2 180 273	17.85	100.0	0	2 180 273
Norway	868 592	23.42	76.7	30 926	837 666
Poland	1 193 362	3.81	81.7	0	1 193 362
Portugal	521 921	5.72	77.3	359 135	162 786
Rumania	426 502	2.25	78.3	0	426 502
San Marino	1 367	8.04	100.0	1 367	0
Spain	2 526 843	8.03	79.5	2 501 108	25 735
Sweden	3 386 925	44.01	96.7	0	3 386 925
Switzerland	2 131 521	35.97	100.0	0	2 131 521
Turkey	308 100	0.99	82.3	0	308 100
U.S.S.R.*	7 200 000	3.14	70.0	0	7 200 000
United Kingdom (5)	9 960 000	18.27	91.2	0	9 960 000
Yugoslavia	369 844	1.91	88.3	0	369 844
AFRICA					
Algeria	139 473	1.13	69.6	0	139 473
Angola (3)	13 821	0.27	70.6	0	13 821
Ascension Island	70	14.64	92.9	70	0
Basutoland	1 214	0.16	71.1	0	1 214
Bechuanaland	1 469	0.27	0.0	0	1 469
Burundi*	2 300	0.08	94.0	0	2 300
Cameroon*	4 100	0.08	74.0	0	4 100
Cape Verde Islands	569	0.26	95.8	0	569
Central African Republic*	2 200	0.17	90.0	0	2 200
Chad*	2 800	0.10	88.0	0	2 800
Comoro Islands	340	0.17	0.0	0	340
Congo (Brazzaville)*	8 000	0.96	93.0	0	8 000
Congo, Democratic Republic	19 789	0.12	83.5	0	19 789
Dahomey*	3 500	0.15	86.0	0	3 500
Equatorial Guinea	1 249	0.47	91.6	1 249	0
Ethiopia	21 404	0.10	83.8	0	21 404
Gabon*	3 000	0.65	95.0	0	3 000
Gambia	1 025	0.31	94.2	0	1 025
Ghana	32 511	0.42	72.4	0	32 511
Guinea*	6 000	0.17	84.0	0	6 000
Ifni	244	0.48	0.0	0	244
Ivory Coast	17 702	0.47	92.6	0	17 702
Kenya	50 644	0.55	82.3	0	50 644
Liberia*	3 000	0.28	100.0	1 000	2 000
Libya	14 213	0.91	90.1	0	14 213
Madagascar	18 450	0.29	63.1	0	18 450
Malawi	6 695	0.17	88.9	0	6 695
Mali*	4 400	0.10	70.0	0	4 400
Mauritania*	1 000	0.12	70.0	0	1 000
Mauritius and Dependencies	12 504	1.70	70.4	0	12 504

TABLE 3—Continued
TELEPHONES BY COUNTRIES AS OF 1 JANUARY 1965

Area	Number of Telephones	Per 100 Population	Percent Automatic	Telephones by Type of Operation (1)	
				Private	Government
Morocco	146 684	1.12	79.9	10 390	136 294
Mozambique	17 985	0.26	78.2	0	17 985
Niger	2 270	0.07	88.0	0	2 270
Nigeria	60 428	0.11	79.6	0	60 428
Portuguese Guinea	958	0.18	60.3	0	958
Réunion	8 718	2.25	0.0	0	8 718
Rhodesia	94 887	2.25	89.7	0	94 887
Rwanda	793	0.03	0.0	0	793
Sahara, Spanish	540	1.29	0.0	0	540
St. Helena	135	2.70	0.0	0	135
São Tomé and Príncipe	496	0.89	65.3	0	496
Sénégal*	25 000	0.73	83.0	0	25 000
Seychelles	309	0.67	100.0	309	0
Sierra Leone*	5 500	0.25	80.0	0	5 500
Somalia*	2 500	0.11	0.0	0	2 500
Somaliland, French	1 200	1.48	100.0	0	1 200
South Africa	1 133 331	6.40	73.7	0	1 133 331
South West Africa	23 286	4.09	38.4	0	23 286
Spanish North Africa	8 320	5.23	100.0	8 320	0
Sudan	35 571	0.27	84.4	0	35 571
Swaziland	3 023	1.05	58.0	0	3 023
Tanzania	20 924	0.21	67.2	0	20 924
Togo	2 779	0.17	74.2	0	2 779
Tunisia*	33 800	0.73	57.0	0	33 800
Uganda	17 747	0.24	79.9	0	17 747
United Arab Republic	301 405	1.03	85.1	0	301 405
Upper Volta*	2 000	0.04	30.0	0	2 000
Zambia	31 382	0.86	96.9	0	31 382
ASIA					
Aden and South Arabia, Protect. (6)	7 078	0.64	98.1	0	7 078
Afghanistan	8 683	0.06	72.0	0	8 683
Bahrein	5 873	3.23	100.0	5 873	0
Bhutan	0	—	—	—	—
Brunei*	1 900	1.92	92.0	0	1 900
Burma*	23 200	0.09	75.0	0	23 200
Cambodia	4 294	0.07	85.9	0	4 294
Ceylon	41 791	0.38	97.8	0	41 791
China, Mainland	244 028	0.05	72.9	94 945	149 083
China, Taiwan	147 825	1.21	66.7	0	147 825
Cyprus	26 290	4.40	99.3	0	26 290
Hong Kong	219 693	5.87	100.0	219 693	0
India	760 000	0.16	55.2	3 154	756 846
Indonesia	204 335	0.19	19.0	0	204 335
Iran	181 130	0.78	79.0	0	181 130
Iraq*	62 000	0.87	80.0	0	62 000
Israel	215 020	8.51	100.0	0	215 020
Japan	12 250 841	12.54	66.7	11 565 239	685 602
Jordan*	25 000	1.29	70.0	0	25 000
Korea, North	n.a.	—	—	—	—
Korea, Republic of	232 901	0.83	65.1	0	232 901
Kuwait	22 133	6.34	100.0	0	22 133
Laos	1 011	0.05	76.7	0	1 011
Lebanon	98 802	4.34	89.4	0	98 802
Macao	2 623	1.50	100.0	0	2 623
Malaysia:					
Malaya	107 582	1.36	91.4	0	107 582
Sabah	6 236	1.20	100.0	0	6 236
Sarawak	7 248	0.86	84.3	0	7 248
Total	121 066	1.31	91.4	0	121 066
Maldive Islands	0	—	—	—	—
Mongolia	13 106	1.21	67.9	0	13 106
Muscat and Oman	317	0.06	100.0	317	0
Nepál	3 000	0.03	50.0	0	3 000
Pakistan	120 525	0.12	73.4	0	120 525
Philippine Republic	151 593	0.48	80.0	135 221	16 372
Portuguese Timor	568	0.10	0.0	0	568
Qatar	5 866	9.78	100.0	5 866	0
Ryukyu Islands	28 538	3.04	82.8	0	28 538
Saudi Arabia*	27 000	0.41	40.0	0	27 000

TABLE 3—Continued
TELEPHONES BY COUNTRIES AS OF 1 JANUARY 1965

Area	Number of Telephones	Per 100 Population	Percent Automatic	Telephones by Type of Operation (1)	
				Private	Government
Sikkim*	250	0.15	0.0	0	250
Singapore	79 199	4.30	100.0	0	79 199
Syria	71 929	1.32	89.4	0	71 929
Thailand	65 191	0.22	90.3	0	65 191
Trucial Oman	1 649	1.26	100.0	1 649	0
Viet-Nam, North	n.a.	—	—	—	—
Viet-Nam, Republic of	20 140	0.13	90.4	0	20 140
West Irian	2 581	0.31	13.7	0	2 581
Yemen*	1 000	0.02	100.0	0	1 000
OCEANIA					
Australia	2 670 212	23.98	81.8	0	2 670 212
British Solomon Islands	617	0.46	98.5	0	617
Canton Island	60	18.75	100.0	0	60
Caroline Islands	750	1.32	0.0	0	750
Christmas Island	127	3.74	100.0	127	0
Cocos (Keeling) Islands	63	6.30	100.0	0	63
Cook Islands	436	2.18	0.0	0	436
Fiji Islands	10 149	2.23	60.1	0	10 149
Gilbert and Ellice Islands	0	—	—	—	—
Guam	15 510	22.48	99.7	0	15 510
Mariana Islands (less Guam)	400	4.00	100.0	0	400
Marshall Islands	1 055	4.59	97.2	0	1 055
Midway Island	1 310	43.67	97.7	0	1 310
Nauru	0	—	—	—	—
New Caledonia	4 152	4.56	76.6	0	4 152
New Hebrides Condominium	550	0.82	100.0	0	550
New Zealand	962 596	36.52	80.3	0	962 596
Niue Island	122	2.44	0.0	0	122
Norfolk Island	43	4.30	0.0	0	43
Papua and New Guinea	8 535	0.40	81.1	0	8 535
Pitcairn Island	0	—	—	—	—
Polynesia, French	3 703	4.21	0.0	0	3 703
Samoa, American	650	3.10	100.0	0	650
Samoa, Western	1 405	1.14	0.0	0	1 405
Tokelau Islands	0	—	—	—	—
Tonga (Friendly) Islands	651	0.92	0.0	0	651
United States: Hawaii	303 960	40.53	100.0	303 960	0
Wake Island	210	14.00	100.0	0	210

TABLE 4
TELEPHONE CONVERSATIONS DURING 1965

Country or Area	Thousands of Conversations			Average Conversations per Person
	Local	Long Distance	Total	
Algeria	85 200	7 538	92 738	7.5
Angola	21 826	696	22 522	4.4
Argentina	4 041 858	57 654	4 099 512	186.0
Australia	2 006 000	95 700	2 101 700	190.6
Bahama Islands	44 314	154	44 468	327.0
Barbados, West Indies	30 000	25	30 025	124.1
Belgium	772 343	183 731	956 074	101.9
Bermuda	16 422	100	16 522	344.2
Brazil	6 606 837	107 365	6 714 202	85.2
British Guiana	10 641	838	11 479	18.3
Cambodia	6 485	503	6 988	1.1
Canada	11 697 788	283 388	11 981 176	622.8
Channel Islands	20 299	1 167	21 466	195.1
Chile	648 328	21 192	669 520	78.8
China, Taiwan	516 552	17 046	533 598	44.2

(1) Data are for the year ended 30 June 1964.
(2) Data are for the year ended 31 March 1964.

(3) Data are for the year ended 30 June 1965.
(4) Data are for the year ended 30 September 1964.

TABLE 4—Continued
TELEPHONE CONVERSATIONS DURING 1965

Country or Area	Thousands of Conversations			Average Conversations per Person
	Local	Long Distance	Total	
Congo, Democratic Republic	16 843	68	16 911	1.1
Costa Rica	51 548	1 780	53 328	38.3
Cuba	1 252 061	14 466	1 266 527	172.6
Cyprus	27 890	2 566	30 456	51.9
Czechoslovakia	900 689	114 069	1 014 758	72.2
Denmark	1 295 436	335 292	1 630 728	342.9
Ethiopia	30 392	1 346	31 738	1.4
Fiji Islands	11 500	1 135	12 635	28.1
France	1 212 500	814 500	2 027 000	41.9
Germany, Eastern	824 881	225 769	1 050 650	61.8
Germany, Federal Republic	4 141 991	1 607 310	5 749 301	98.6
Ghana	27 007	2 901	29 908	3.9
Gibraltar	7 128	96	7 224	301.0
Greece	874 986	24 193	899 179	105.2
Guadeloupe	2 819	442	3 261	10.7
Hungary	570 939	35 243	606 182	59.9
Iceland	122 962	3 718	126 680	67.0
Ireland	171 150	20 850	192 000	67.4
Italy	7 133 573	744 964 (4)	7 878 537	154.6
Ivory Coast	14 765	608	15 373	4.1
Jamaica, West Indies	72 434	1 036	73 470	42.5
Korea, Republic of	1 442 220	23 499	1 465 719	53.0
Lebanon	188 800	8 581	197 381	87.7
Libya	25 612	669	26 281	16.9
Liechtenstein	2 189	2 289 (4)	4 478	248.8
Madagascar	15 193	917	16 110	2.6
México	1 579 973	29 180	1 609 153	40.6
Morocco	133 216	9 555	142 771	11.0
Mozambique	24 730	1 848	26 578	3.9
Netherlands	1 308 856	669 293	1 978 149	163.2
Netherlands Antilles	32 475	42	32 517	158.6
New Caledonia	2 644	238	2 882	32.4
Nicaragua	21 118	603	21 721	13.6
Nigeria	87 836	4 158	91 994	1.6
Norway	602 271	68 885	671 156	181.6
Papua and New Guinea	7 327	191	7 518	3.6
Peru	476 389	9 253	485 642	42.8
Philippine Republic	1 079 850	1 542	1 081 392	34.6
Polynesia, French	1 600	118	1 718	20.0
Portugal	473 716	56 506	530 222	58.2
Puerto Rico	358 760	7 532	366 292	142.4
Réunion	3 822	372	4 194	11.0
Rhodesia	79 110	8 534	87 644	21.2
Ryukyu Islands	68 000	1 957	69 957	74.5
Sarawak	16 393	1 073	17 466	21.3
Singapore	243 068	1 658	244 726	134.5
South Africa (2)	1 508 785	104 033	1 612 818	92.0
South West Africa	17 677	2 782	20 459	36.3
Swaziland	1 300	660	1 960	6.9
Sweden (3)	2 953 000	507 000	3 460 000	449.6
Switzerland	778,989	829 231 (4)	1 608 220	273.8
Syria	107 250	3 149	110 399	20.4
Thailand (4)	121 766	400	122 166	4.1
Trinidad and Tobago, West Indies	112 843	9 751	122 594	129.0
Turkey	297 962	18 649	316 611	10.3
United Arab Republic	570 800	19 364	590 164	20.4
United Kingdom (2)	5 650 000	743 600	6 393 600	118.2
United States	109 262 000	4 334 000	113 596 000	591.0
Viet Nam, Republic of	29 824	378	30 202	1.9
Virgin Islands, (United States)	25 241	195	25 436	620.4
Yugoslavia	513 191	43 013	556 204	28.9

United States Patents Issued to International Telephone and Telegraph System; February 1965–April 1965

Between 1 February 1965 and 30 April 1965, the United States Patent Office issued 72 patents to the International System. The names of the inventors, company affiliations, subjects, and patent numbers are listed below.

R. T. Adams and B. M. Mindes, ITT Laboratories, Frequency Stabilized Oscillator, 3 176 245.

R. T. Adams and B. M. Mindes, ITT Federal Laboratories, Logical Switching System for Input and Output Signals Characterized by Various Stable Frequencies, 3 176 233.

D. C. Alexander and H. L. Pibus, ITT Surprenant, Insulated Electrical Cable, 3 176 065.

M. Arditì, ITT Laboratories, Atomic Clock, 3 174 114.

E. A. Ash, Standard Telecommunication Laboratories (London), Delay Line for Travelling Wave Tube, 3 181 090.

E. A. Ash, Standard Telecommunication Laboratories (London), Waveguide Coupled Tuning of Cavity Resonators for Klystrons, 3 181 025.

R. Bayer and G. Beszedics, Standard Telephone und Telegraphen (Vienna), Loudspeaking Intercommunication System, 3 175 045.

H. Brause, Standard Elektrik Lorenz (Stuttgart), Corner Guide for Upright Conveyor Systems, 3 180 481.

A. E. Brewster, Standard Telecommunication Laboratories (London), Magnetic Trigger Devices, 3 181 001.

A. E. Brewster and M. Beasley, Standard Telephones and Cables (London), Electric Pulse Distributors, 3 174 050.

G. Buhmann, Standard Elektrik Lorenz (Stuttgart), Method and Apparatus for Making Coaxial Cables, 3 180 910.

E. L. Byer and J. Cuccio, ITT Industrial Laboratories, Combined Television Transmitter and Telephone, Design 200 470.

E. L. Byer and J. Cuccio, ITT Industrial Lab-

oratories, Combined Television Receiver and Telephone, Design 200 975.

R. Chapman, Kolster-Brandes (Kent), Electrical Amplifiers, 3 175 046.

M. J. Cotterill, ITT Federal Laboratories, Compandor, 3 181 074.

B. Dal Bianco and M. Scata, Fabbrica Apparecchiature per Comunicazioni Elettriche Standard (Milan), Electromagnetically Actuated Optical Signalling Device, 3 178 703.

C. L. Day, ITT Federal Laboratories, Target Electrode for Barrier Grid Storage Tube, 3 181 021.

G. A. Deschamps, Federal Telecommunication Laboratories, Attitude Computer, 3 176 119.

T. P. Dixon, ITT Federal Laboratories, Reticle for an Infrared Tracking System Having Groups of Spokes and Each Spoke of Each Group Parallel with the Other Spoke, 3 180 991.

H. J. Dreyer, R. Basten, and G. Porst, Standard Elektrik Lorenz (Stuttgart), Program-Controlled Electronic Data-Processing System, 3 174 135.

R. H. Duncan and T. P. Miller, ITT Kellogg, Cordless Switchboard, 3 176 081.

E. H. Eberhardt, ITT Federal Laboratories, Radar Storage Tube for Indicating Moving Objects, 3 174 071.

S. J. Erst, Farnsworth Electronics Company, F.M. Continuous Wave Radar System, 3 173 138.

D. K. Everitt, ITT General Controls, Combination Safety-Pilot and Diaphragm Valve, Design 200 454.

P. T. Farnsworth, ITT Federal Laboratories, Ion Transport Vacuum Pump, 3 181 028.

B. K. Fielder, Standard Telephones and Cables (London), Electrical Connectors, 3 181 106.

A. J. Franchi, ITT Kellogg, Audio Actuated Switch for Transceiver Transmitter, 3 169 221.

E. Garber and K. Eckardt, Standard Elektrik Lorenz (Stuttgart), Contact Clamp, 3 181 107.

- J. J. Gasser, ITT Kellogg, Machine Tool Control Circuit Having a Program Crossbar Switch and a Bridge Means for Checking Crosspoints, 3 175 190.
- W. L. Glomb, ITT Laboratories, Repeater Terminal for Frequency Division Multiplex Communication Systems, 3 180 938.
- A. R. Gobat and D. I. Pomerantz, Federal Telecommunication Laboratories, Method of Making Crystalline Silicon Semiconductor Material, 3 173 765.
- B. J. Grace, ITT Kellogg, Pulse Generator Circuit Having Magnetic Core Timing Means, 3 175 098.
- R. J. Heppe and R. L. Pickholtz, ITT Laboratories, Distance Measuring Apparatus Having a Digital Output Circuit, 3 180 205.
- R. J. Heppe and R. L. Pickholtz, ITT Federal Laboratories, Cryptosecure Transmission System, 3 180 927.
- J. F. Houdek, Jr., ITT Kellogg, Ringer Clapper Assembly, 3 172 100.
- R. A. Hyman, Standard Telephones and Cables (London), Negative Resistance Pulse Repeater Enclosed Within a Coaxial Cable, 3 176 076.
- A. J. Judeinstein, Laboratoire Central de Télécommunications (Paris), Analog to Digital Converter, 3 181 137.
- K. A. Karow, ITT Kellogg, Programmed Machine Tool System, 3 175 188.
- J. F. Kelly, ITT Cannon Electric, Electrical Connector Contact and Insulator Retention System, 3 172 721.
- G. F. Klepp, Standard Telephones and Cables (London), Constant Time Delay Circuit Utilizing Thermal Delay Switches Connected in Tandem, 3 181 037.
- E. Kramar and F. Steiner, Standard Elektriz Lorenz (Stuttgart), Omnidirectional Bearing System, 3 181 159.
- E. H. Lambourn, Standard Telecommunication Laboratories (London), Electric Pulse Code Translators, 3 181 136.
- E. R. LeClear, ITT Federal Laboratories, System for Determining the Percentage "ON" Time of a Random Signal with Respect to a Predetermined Period, 3 179 882.
- L. Lewin and C. C. Eaglesfield, Standard Telecommunication Laboratories (London), Waveguide Corner Junction With Improved Operation by Use of Diaphragms Reflective at Glancing Angle, 3 181 088.
- A. M. Lieberman, ITT, Device for the Automatic Recognition of Written or Printed Characters, 3 181 120.
- J. Losch and H. Zschekel, Mix & Genest Werke (Stuttgart), Electronic Programme-Control, 3 181 121.
- O. J. Melhus, Standard Elektriz Lorenz (Stuttgart), Circuit Arrangement for the Counting Stages of a Ring Counter, 3 181 006.
- G. Merz, Standard Elektriz Lorenz (Stuttgart), Magnetic Core Storage Matrix, 3 181 127.
- F. M. Michiels, Bell Telephone Manufacturing Company (Antwerp), Magnetic Tape Unit, Design 200 959.
- T. P. Miller and R. H. Duncan, ITT Kellogg, Portable Cordless Switchboard, 3 177 293.
- M. Muller, Standard Elektriz Lorenz (Stuttgart), High Frequency Tunnel-Diode Oscillator, 3 181 083.
- H. H. Naidich, ITT Federal Laboratories, Multiple Scan Converter Display System, 3 181 140.
- T. B. Norling and M. A. Jacobs, ITT Kellogg, Local Prepay Paystation with Delayed Call Provisions, 3 177 290.
- A. Pierrot and Y. Lescroel, Lignes Télégraphiques et Téléphoniques (Paris), Molybdenum Oxide Containing High Permeability Zinc-Manganese, 3 180 833.
- R. E. Poole, ITT Federal Laboratories, System for Pulse Amplitude Measurement, 3 173 089.
- V. E. Porter, ITT Kellogg, Electronic Switching Telephone System, 3 177 291.

R. Prichard, ITT Kellogg, Pulse Dividing Circuit, 3 175 130.

W. A. Ray and L. C. Biggle, ITT General Controls, Means and Techniques for Silencing Solenoid-Operated Devices, 3 179 859.

W. L. Sanborn, ITT Bell and Gossett Hydraulics, Supply Tank for Viscous Materials, 3 180 376.

R. W. A. Scarr, I. Aleksander, and R. W. Hunt, Standard Telephones and Cables (London), Counter Employing Tunnel Diode Chain and Reset Means, 3 181 005.

R. Scheidig, Mix & Genest Werke (Stuttgart), Reed Contact Arranged Within a Protective Envelope, 3 170 053.

L. Schroth, Mix & Genest Werke (Stuttgart), Photosensitive Document Identification Apparatus, 3 176 140.

W. R. Sloan, ITT Laboratories, Character Generating Tube, 3 181 026.

K. Steinbuch and H. Reiner, Standard Elektrik Lorenz (Stuttgart), Electric Translator of the Matrix Type Comprising a Coupling Capacitor Capable of Having One of a Plurality of Possible Values Connected Between Each Row and Column Wire, 3 174 134.

T. N. Tilman, Jennings Radio Manufacturing Corporation, Remotely Actuated Vacuum Coaxial Switch with Reduced-in-Thickness Contact Portions for Eliminating Cross-Talk, 3 171 090.

F. J. L. Turner, Creed and Company (Brighton), Serial Number Printing Apparatus, 3 173 359.

F. Ulrich, Standard Elektrik Lorenz (Stuttgart), Pulse-Storage Devices With Automatic Series Read-Out, 3 175 102.

L. M. Vallese and L. Himmel, ITT Federal Laboratories, System for Cancellation of Ground Reflections, 3 176 231.

J. Villiers, Purchased Invention, Rotating Radio-Beacon System for Locating Objects, 3 181 141.

J. Villiers, Purchased Invention, Air Radio Navigation Control Systems, 3 181 142.

J. Villiers, Purchased Invention, Aerial Navigation System with Beacon Identification, 3 176 290.

J. Villiers, Purchased Invention, Omni-Directional Altimetric Radar, 3 181 143.

M. C. Vosburgh and S. M. Khanna, ITT Laboratories, Doppler Radar System, 3 174 147.

R. W. Warren, Standard Telecommunication Laboratories (London), Water Cooled Crucible for Zone Refining, 3 172 734.

R. W. Wilmarth, ITT Federal Laboratories, Backward Wave Converter Tube With Double Conversion Including a Frequency Control Loop, 3 176 232.

E. P. G. Wright, D. A. Weir, R. C. P. Hinton, and B. Dzula, Standard Telecommunication Laboratories (London), Data Processing Systems, 3 181 123.

Delay Line for Travelling Wave Tube

3 181 090

E. A. Ash

This patent discloses a slow-wave structure for use in a travelling-wave tube. It is composed of two or more wires forming a mesh pattern between a pair of spaced parallel conducting sidewalls.

Loudspeaking Intercommunication System

3 175 045

R. Bayer and G. Beszedics

A simple loudspeaker intercommunication system is described in which connections may be made between any two units by selective switching, and in which, by the use of rectifiers, signalling is transmitted only to the desired station, and privacy of the conversation is also maintained.

Recent Achievements

Voice of Peace—A recommendation to create a “Voice of Peace,” a new information-sharing agency within the United Nations, was made by Harold S. Geneen, chairman and president of International Telephone and Telegraph Corporation, on 30 November 1965 at the White House Conference on International Cooperation in Washington, District of Columbia.

The Voice of Peace would be a new agency of the United Nations. Staffed on a continuous basis by the developed nations of the world, it would be a central point of information, query, storage, and reference for use by all participating nations. The computer-based center would gather, store, process, program, retrieve, and distribute information on the broadest possible scale.

If requested information is unavailable or incomplete, queries would be referred to experts. The Voice of Peace staff would include qualified professionals in various fields such as medicine, agriculture, meteorology, and other numerous areas in which expertise is critical. The staff would be established on a rotating basis with specified periods of service and would include a small cadre of permanent employees.

There are sufficient telecommunications systems now available to handle the Voice of Peace traffic anticipated in the immediate future. Simple message forms would be designed for such communication.

Mr. Geneen said that his proposal would not infringe on the efforts of existing agencies of the United Nations, but would augment their programs as they become a part of the Voice of Peace.

*International Telephone and Telegraph Corporation
United States of America*

Live Television Coverage of Gemini Spacecraft Recoveries at Sea—Transmitting from the rolling deck of the United States Navy aircraft carrier Wasp, a transportable earth station initiated a new era in television broadcasting by beaming its signals to the Early Bird satellite,

which relayed them to the ground station at Andover, Maine, from where they were sent to the television broadcast networks in the United States. The Gemini 6 pictures were broadcast throughout the United States on 16 December 1965 and two days later the Gemini 7 televised report went to Europe also via Early Bird.

Developed for fast-moving random-orbit satellites, the transportable earth station readily compensated for strong winds and the motions of the Wasp to keep its antenna shown in Figure 1 pointed constantly at the synchronous satellite. The station was installed on the carrier in 2 days and was operational in 4 days. A 30-foot communications van was located a deck below the antenna.

One of 9 such stations built by ITT Federal Laboratories since 1959, it was operated by ITT World Communications. The close cooperation of the United States Navy, Communications Satellite Corporation, National Aeronautics and Space Administration, Federal Communications Commission, and the three major television networks in the United States was indispensable in bringing these live programs to the general public.

At Kennedy Space Center a staff of engineers maintained by Federal Electric Corporation certified more than 3000 pieces of test equipment to assure the reliability of the Gemini instruments. Among other services provided by Federal Electric Corporation was the reduction of data received from the Gemini spacecraft into form suitable for the scientific computers of the Center. Precise time accurate to within 10^{-6} second was maintained for control of computers, tracking radars, monitoring recorders, special cameras, and various kinds of checkout equipment. Still other teams of Federal Electric Corporation served both ashore and at sea in tracking stations.

In anticipation of future Gemini missions in which astronauts will again walk in space, 6 radio transceivers have been delivered by ITT Federal Laboratories. Of welded cordwood construction, weighing only 15 ounces (0.4 kilo-

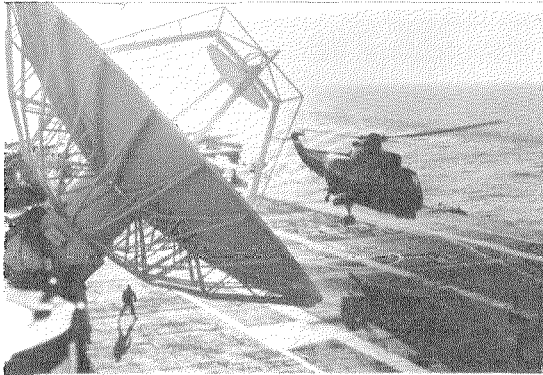

Figure 1—Antenna of transportable earth station on board U.S.S. Wasp for live coverage of the Gemini 6 and 7 flights via Early Bird satellite. The operating van was on a deck below the antenna.



Figure 2—Visitors at the International System display in Madrid included (1) Márquez Mira, President of Standard Eléctrica; (2) López Bravo, Minister of Industry; (3) Márquez Balin, General Manager of Standard Eléctrica; and (4) M. Novoa, Director of Telecommunication Engineers School.

gram), and measuring 8.6 by 1.8 by 1 inches (22 by 4.6 by 2.5 centimeters), they provide for voice communication with amplitude modulation at 296.8 megahertz. They will be part of a maneuvering unit mounted on the back of the astronaut and will give an abort warning should certain parameters of the maneuvering unit fall below specified limits.

United States of America

International Congress on Telecommunications

—The second International Congress on Telecommunication Techniques was held in Madrid, Spain, on 14–20 November 1965. Of the 130 papers presented, ITT System companies contributed 34. Among these were papers on digital techniques for telephone transmission, multi-frequency signaling for telephone networks, transistor repeaters for submarine cables, tropospheric radio systems, Videx slow-scan television, mobile telephones, satellite communications, radar systems, lasers, magnetic memories, digital computers, telemetry and telecontrol, electronic switching, solid-state techniques, and new components.

At the exhibition of telecommunication equipment that was part of the event the largest

display, part of which is shown in Figure 2, was by Standard Eléctrica. It included products and activities of about a dozen ITT associate companies including its compatriot, Compañía Internacional de Telecomunicación y Electrónica.

*Standard Eléctrica
Spain*

Zambia Gets First Radio Factory—The first radio factory in Zambia is on the outskirts of Livingstone. On a 4.5-acre (18 200-square-meter) site the plant contains 39 000 square feet (3600 square meters).

Initially it will employ 160 natives in the manufacture of transistor radio equipment for the Zambian market and for export to other African countries. Preliminary training started before production and will continue on a permanent basis to ensure skilled workers.

At the laying of the foundation stone as shown in Figure 3, Rex B. Grey, chairman of the parent company (Standard Telephones and Cables) and of Supersonic Radio Zambia, stated, “As the business grows we shall extend

Recent Achievements



Figure 3—His Excellency Dr. Kenneth Kaunda, President of the Republic of Zambia, and Rex B. Grey, Chairman of Standard Telephones and Cables and of Supersonic Radio Zambia, at the laying of the foundation stone of the new plant in Livingstone.

the plant for the manufacture of telecommunications equipment, for which there is an ever-growing demand. Within four years we hope to employ some 400 people”.

*Standard Telephones and Cables
United Kingdom*

Laser Machining of Thin Metal Films—The 1-millimeter (0.04-inch) diameter beam of an ionized argon laser operating at 4880 angstrom units with an output of 500 milliwatts can be reduced with a conventional short-focus lens to vaporize thin metal films. By control of the power of the laser or of the rate of motion over the film, lines varying between 10 and 50 microns may be made in iron-nickel films evaporated on glass substrates.

The blue laser beam may pass through the glass wall of an evacuated enclosure to machine sealed-in parts. It will thus permit manufacture and later adjustment of magnetic-film memories, microelectronic devices, and integrated circuits.

*Laboratoire Central de Télécommunications
France*

Mobile Telephone Exchange—To provide telephone switching facilities to communities that have experienced unforeseen rapid growth, the German telephone administration has introduced mobile central offices.

The first such exchange was put in service in October 1965 in the Stuttgart area serving the suburbs of Feuerbach, Zuffenhausen, and Stammheim. With a capacity for 900 individual and 90 shared-service lines, it may be expanded to 1300 lines. It uses the same kind of equipment found in the conventional central offices with which it interworks.

*Standard Elektrik Lorenz
Germany*

Pico* Microwave Terminal—A microwave terminal containing a receiver, transmitter, order wire with handset, high-gain planar array antenna, and power supply is shown in Figure 4. About the size of an attaché case, it can accommodate multichannel voice, data, television, or radar signals. With a companion modem for 12–24 voice channels, the complete terminal requires less than 1.5 cubic feet (0.04 cubic meter) and weighs approximately 50 pounds (23 kilograms).

Pico terminals come in four configurations: A) the one described with integral flat-pack antenna, B) with the equipment around the neck of a horn antenna, C) installed in a torpedo-shaped housing for tower mounting, and D) rack mounted.

The torpedo-shaped version is particularly effective for installation in remote rugged locations. Using neither klystron nor other tubes, this 5-watt unit with integral power supply weighs only 37 pounds (17 kilograms) and is 20 inches (51 centimeters) long by 5.5 inches (14 centimeters) in diameter. It can be accommodated on existing microwave towers without danger of overload.

* Trademark.

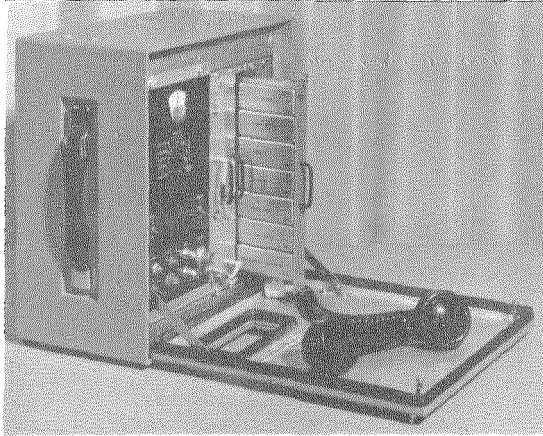

Figure 4—Pico microwave terminal is about the size of an attaché case.

All versions may be connected to their self-contained antennas, to any other suitable antenna, or to an external power amplifier. They may be operated from alternating-current or from nickel-cadmium rechargeable cells. A pilot tone is provided for monitoring and maintenance. Clearly labeled and easily replaceable individual modules employ hybrid thick-film and solid-state components on alumina ceramic substrates. They plug into secondary boards that plug into the Pico case or frame.

The availability of the equipment was announced in both the United Kingdom and the United States.

*ITT Federal Laboratories
United States of America*

High-Slope Varactor—An epitaxial gallium-arsenide layer can be grown on a semi-insulating substrate, and varactors have been made by diffusing into such a layer to give the structure shown in Figure 5. As the reverse voltage applied to the contacts is increased, the junction depletion layer widens until it reaches the semi-insulating substrate. At this point the capacitance of the device collapses as charge carriers are swept from beneath the main area.

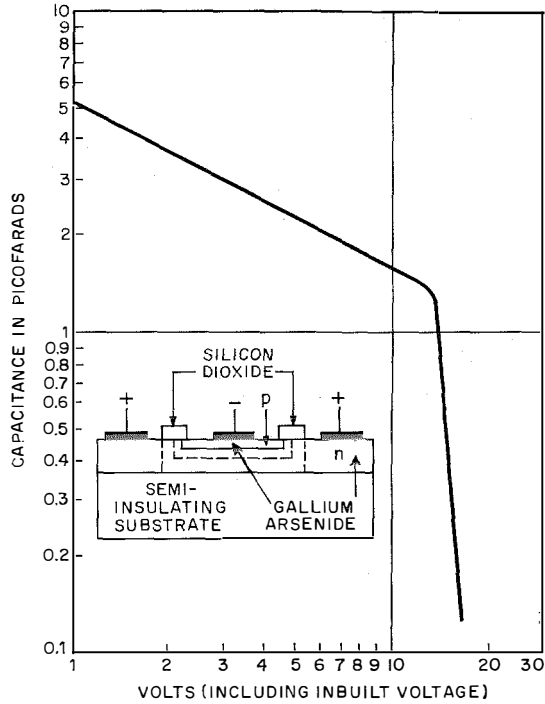

Figure 5—Construction and capacitance-voltage characteristic of high-slope varactor.

The large range of capacitance as a function of voltage makes the device attractive as a tuning capacitor. Cutoff frequencies of about 100 megahertz were achieved with early samples.

*Standard Telecommunication Laboratories
United Kingdom*

Germany Introduces Small-Core Coaxial Cable Into Telephone Network

Solid-state modem and repeater equipment has been developed for transmitting 300 and 960 voice channels over a new size of coaxial cable of 1.2/4.4 millimeters. Unattended dependent repeaters, often buried, are spaced at 4 kilometers (2.5 miles) for 960 channels and at either 6 or 8 kilometers (3.75 or 5 miles) for 300 channels. Power for as many as 24 dependent repeaters is sent over the cable from the nearest main station. The

Recent Achievements

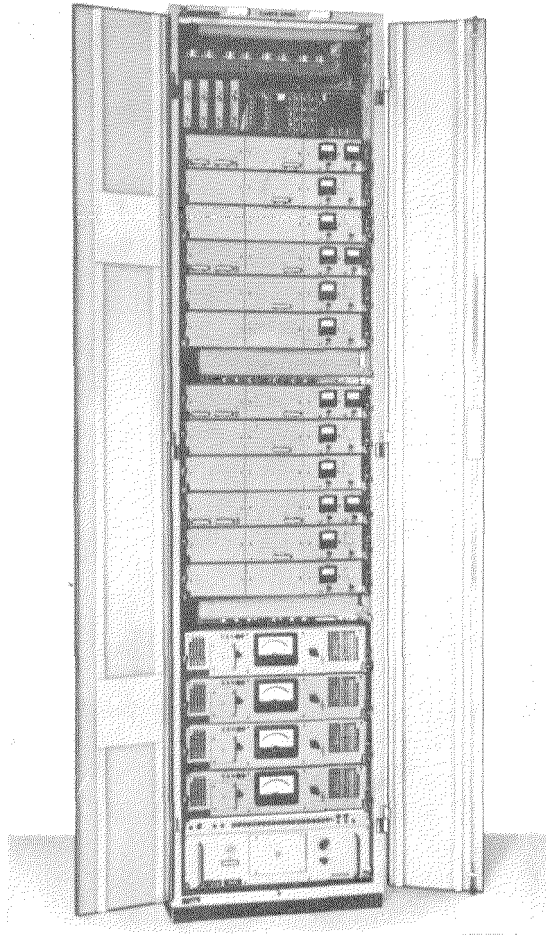

Figure 6—Bay equipped with 4 terminal repeaters for 960-channel transmission over new small-diameter coaxial cable.

gain of each dependent repeater is temperature controlled. Pilots control the gain of the main repeaters and for unfavorable conditions may also control dependent repeaters.

The first 300-channel system was installed in the Düsseldorf area and used 6-kilometer (3.75-mile) repeater spacing. Another cable route was equipped first for 960 channels and later for 300 channels with 8-kilometer (5-mile) repeater spacing for field trials. All of these

equipments meet the requirements and are now in series production. Terminal repeaters are shown in Figure 6.

*Standard Elektrik Lorenz
Germany*

Satellite Launched by French—On 26 November 1965 the French satellite A_1 was successfully launched at Hammaguir, Algeria, using the Diamant launch vehicle.

Two sequences programmers were supplied. Type A was mounted on the launch vehicle to time the various operations of separating the first 2 rocket stages, firing the 2nd stage, actuating a rocking system, actuating the firing timers of the 3rd stage, putting the vehicle into rotation, and separation of the 2nd and 3rd stages.

The type C unit was in the satellite for controlling the jettisoning of the heat shield, the deployment of the telemetry antenna, and for providing various orders for the telemetry transmitter and the radar transponder. The two units are shown in Figure 7.

*Laboratoire Central de Télécommunications
France*

Pseudo-Noise Code Generator—A 13-stage pseudo-random code generator has been developed for command and telemetry links, electronic countermeasures, code-division multiplex, ranging, and jam-resistant systems. Using clock frequencies up to 5 megahertz, it may be simply switched to any of 600 maximum-length code sequences while simultaneously generating two orthogonal coding waveforms. It can also generate test signals for aligning balanced modulators with which it works.

The code is changed remotely by switching logic inputs that control the generator's modulo-2 adders. An automatic starting circuit injects 1 's into the system if an all- 0 condition exists so that a buffered all- 1 's pulse is provided for synchronization.

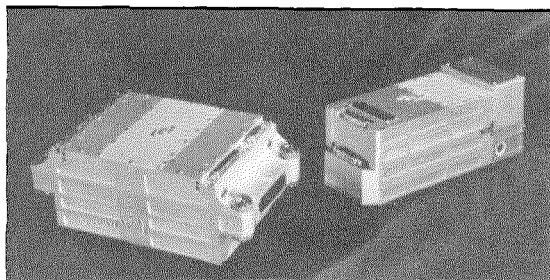

Figure 7—Type *A* (left) and type *C* programmers for the Diamant launching of the French *A₁* satellite.

As shown in Figure 8 construction using standard microelectronic integrated circuits has reduced size to 3.25 by 1.25 by 1.25 inches (8.3 by 3.2 by 3.2 centimeters) and power to 2 watts compared with dimensions of 11.5 by 4 by 3.5 inches (29 by 10.2 by 8.9 centimeters) and 15 watts for a design in conventional solid state.

The present housing can accommodate 22 stages although only 13 stages are needed to meet the aerospace application for which it was designed. Commercial versions are anticipated.

*ITT Federal Laboratories
United States of America*

High-Speed Data Over Pulse-Code-Modulated Telephone Network—Pulse-code modulation is already being used for multiplex telephone transmission in many parts of the world. Such a telephone channel with regenerative repeaters has a capacity of 56 kilobauds, which is much greater than the digital capacity of an analog telephone channel.

In an experimental system, digital data may be injected into the pulse stream in place of one of the speech channels. The system will accept asynchronous data in the range 16 to 48 kilobauds. The telephone channel uses 7 digits recurring at 8 kilohertz (occupying a 4.6-microsecond time slot in a 24-channel system). At the sending end, data incoming during each

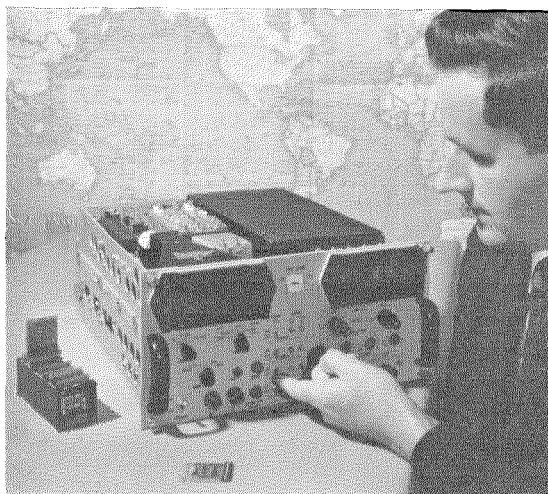

Figure 8—Comparison of solid-state (right) and integrated-circuit versions of a pseudo-noise code generator.

125-microsecond period is stored in a register to the end of that period and then injected as a burst into the digit stream, together with coded information of the data rate, during the allocated time slot.

At the receiving end the bunched data is written into a register from which it is read isochronously. The original data clock timing is reconstructed by using the coded data rate information to control the phase and frequency of an oscillator. This oscillator will lock to any data clock frequency in two ranges (16–40 and 40–48 kilobauds) with no manual adjustment other than selecting the range.

*Standard Telecommunication Laboratories
United Kingdom*

Stabilized Rectifier for Battery Charging—A fully automatic stabilized rectifier has been developed for charging from 1 to 4 nickel-cadmium batteries of 6 volts with a stabilized current of 5 amperes. Terminals are provided for charging 1 to 12 gastight cells rated at 1.2 volts

Recent Achievements

and 1.5 ampere-hours with a stabilized current of 150 milliamperes. These units were developed for military purposes and are shown in Figure 9.

*Nederlandsche Standard Electric Maatschappij
The Netherlands*

Brokers Telephone Switching System—A telephone switching system has been developed to permit brokers to receive and to rapidly set up calls over the public network central office, private branch exchanges, and direct lines to their agents in the city. Each line appears on the broker's position as a combined lamp and push button. Several such positions may be multiplied for central-office and agents' lines. The private branch exchange lines and lines to other brokers appear on only one position. The transfer of outside calls by the broker to one of his agents is an optional feature.

The system has a capacity of 143 lines and 20 brokers' positions. Each broker position has two handsets for simultaneous conversations. The switching equipment, which is silent in operation, is mounted in metal cabinets for ease of installation.

Such a system is particularly useful in large banks.

*Bell Telephone Manufacturing Company
Belgium*

Berlin and Madrid Add to Mail Automation—The post offices of both Berlin and Madrid have each added 2 mail-culling and 2 letter-facing machines to their existing mail-handling equipment. In Madrid the letter-facing units employ photoelectric scanning as fluorescent stamps are not in use in that country.

*Standard Elektrik Lorenz
Germany
Standard Eléctrica
Spain*

Ship-to-Shore Teleprinter Service—A teleprinter aboard the S.S. Philippine Bear and another

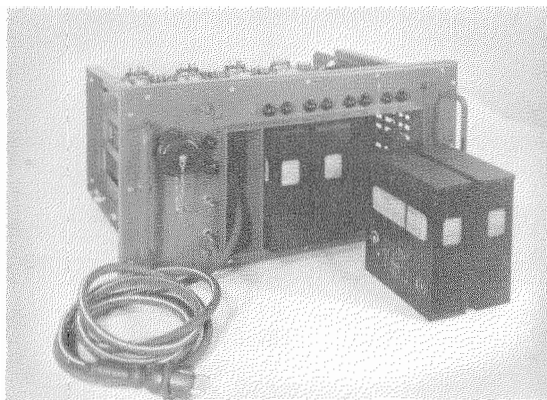

Figure 9—Stabilized battery charger with 2 of 4 batteries in place.

in the office of the Pacific Far East Lines initiated commercial ship-to-shore telex via KFS, the San Francisco coastal station of ITT World Communications. Such service will give ships at sea direct access to telex subscribers in more than 100 countries via coastal radio stations and the international telex network.

The low cost of telex compared with conventional radiotelegraphy will make ship operation more effective through the exchange of an increased volume of information concerning cargo, inventory replacements, ship engineering data, weather conditions, payroll, et cetera.

The radio teleprinters and associated shipboard equipment were supplied by ITT Mackay Marine.

*ITT World Communications
United States of America*

Traveling-Wave Tube for 4 Gigahertz—The W7/5G traveling-wave tube shown in Figure 10 is for use in 1800-channel radio links in the 3.6–4.2-gigahertz band. With a gain of 43 decibels, it has a working output of 20 watts and a saturated output of 30 watts. Using the same driving power, it will produce twice the output of previous tubes.

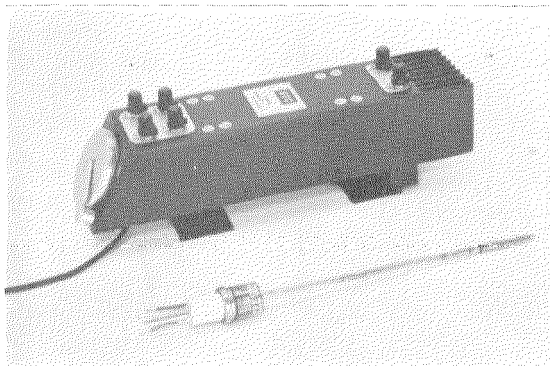

Figure 10—Traveling-wave tube and mount for operation in the band from 3.6 to 4.2 gigahertz.

Incorporated in the *WM110A* mount are the periodic permanent magnets, input and output waveguides, mechanical alignment adjustments, deflection and matching adjustments, convection cooler, and facilities for replacing the tube.

Standard Telephones and Cables
United Kingdom

Air France Telephone System—A Pentaconta crossbar telephone system has been installed in the new Paris headquarters of Air France. It is equipped for 1600 extensions, 14 operators' positions, and 170 trunks. It has capacity for 2500 extensions, 20 operators' positions, and 260 trunks. There are also 70 tie lines connecting it to about 5000 extensions in the 11 Air France installations in the Paris area, all of which are available by direct dialing.

The new premises also have a *PRO 411* Dirigent Confort 2-channel loudspeaker intercommunication system. Its 100 extensions are arranged in 8 groups and are connected through a crossbar automatic exchange.

Compagnie Générale de Constructions Téléphoniques
France

Super-High-Frequency Multichannel Radio Links

—After successful acceptance tests by the German Bundespost engineers, equipment for a 2-hop go-and-return trial installation of the *FM-1800/TV-6000* system has been delivered to the German administration.

The solid-state 70-megahertz modem equipment to accommodate 1800 standard 4-kilohertz voice channels is described together with the radio link design in volume 40, number 2, of *Electrical Communication*.

Standard Elektrik Lorenz
Germany

Sonar Trainer—A system for training sonar operators has been delivered to the United States Navy. It provides for three separate functions.

A helicopter-mounted unit records the sounds detected by a sensing device submerged in the sea. The second part of the system is used to edit these records, to add voice comments for instruction purposes, to produce a master tape, and to provide duplicate tapes for instruction. The third element is the trainer for teaching procedures for detecting and classifying sonar targets. It simulates the operational sonar units installed in helicopters used for submarine patrol.

ITT Federal Laboratories
United States of America

Computer Forecasts French Elections—The first experiment in broadcasting reports on and successive forecasts of the end results of a presidential election in Europe occurred on 5 December 1965 through radio station Europe Number 1.

Sampling techniques were established by an independent organization and the computer and its program were supplied by Centre Française de Recherche Opérationnelle.

Recent Achievements

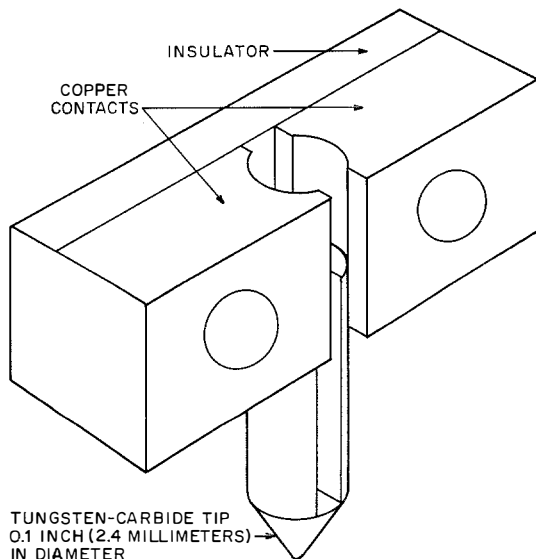

Figure 11—Bonding tool in which a hairpin-shaped tungsten-carbide electrode with a conical tip is heated by an electric current passing through it.

Less than 2 hours after the polls closed, the computer predicted that President Charles de Gaulle would receive between 43 and 45 percent of the votes. He received 43.8 percent. In the second vote on 19 December 1965, his election was forecast 4 minutes after the polls closed and 20 minutes later the computer estimated the count to be 55 ± 2 percent. It was 55.2 percent.

*Centre Française de Recherche Opérationnelle
France*

Heated Compression Bonding Tool—A cone-shaped tungsten-carbide tip brazed to copper contacts, as shown in Figure 11, is mounted on a light semiautomatic welding machine in which time, temperature, and pressure are accurately controlled. It is useful for bonding gold or aluminum wire to metal films. By passing 100 amperes through the tip for a second or two, it is heated to 450 degrees Celsius.

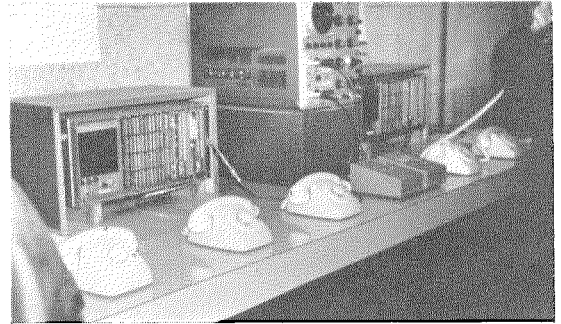

Figure 12—Two pulse-code-modulation telephone terminal equipments for 24-channel operations over a 4-wire telephone circuit shown with a conventional oscilloscope.

The substrate need not be preheated. A hole axially through the tip permits wire to be fed directly from a spool into the tip.

The device can also be used as a quick-heat soldering iron with controlled parameters for making miniature soldered joints between pre-tinned surfaces.

*Standard Telecommunication Laboratories
United Kingdom*

Pulse-Code-Modulated Telephone System—A demonstration was given at the Second International Congress on Telecommunication Techniques in Madrid of a 24-channel pulse-code modulation transmission equipment for use over short interexchange junctions or as a part of an integrated switching and transmission system.

The choice of sampling rate and quantization steps gave excellent speech quality, and the regeneration of pulses within repeaters maintained this quality independent of transmission distance. Two nonloaded telephone pairs are used in a 4-wire connection to provide for speech in both directions. An 8000-baud signaling channel was associated with each such

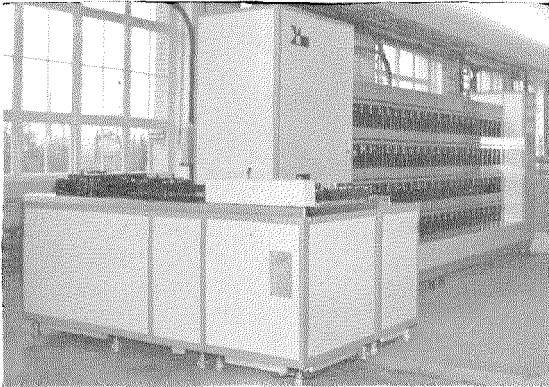

Figure 13—Automatic letter-sorting machine that reads 4-digit code numbers and sorts to 100 destinations.

circuit. Repeaters were spaced at 2 kilometers (1.25 miles).

The small size of the equipment is evident in Figure 12. The use of micrologic devices ensures reliability and reduces power consumption.

*Laboratoire Central de Télécommunications
France*

Letter-Sorting Machine—An automatic letter-sorting machine, F 8410, is shown in Figure 13. It will read 4-digit code numbers at a rate of 20 000 letters per hour and sort to 100 destinations.

By using a chain conveyor with cleats to hold the letters and deflectors that are actuated to direct each letter into its designated destination box, moving masses are kept small to reduce noise and wear.

The distribution program for either incoming or outgoing mail is set by switches. The destination boxes are emptied from one side and their contents are directly visible. Special importance was placed on accessibility of parts for simple maintenance.

*Standard Elektrik Lorenz
Germany*

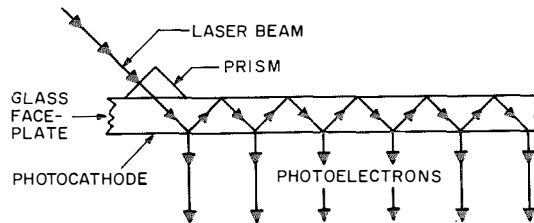

Figure 14—Increased response is obtained by producing multiple reflections of a laser beam within the glass faceplate of a multiplier phototube.

Phototube Response to Laser Beam Improved—

The response to a laser beam of a special *F4003* low-noise multiplier phototube with an *S-20* photocathode has been increased by admitting the beam through a prism on the faceplate of the tube so that it enters at an angle of 52 degrees and is reflected across the faceplate as shown in Figure 14. The special faceplate and imaging section provide an instantaneous effective photocathode of rectangular shape 0.75 by 0.1 inch (19 by 2.5 millimeters).

An increase in quantum efficiency of 3.5 times at 6493 angstroms and 2.5 times at 5230 angstroms has been demonstrated. With specially processed doped trialkali photocathodes, response at 8000 angstroms is 9 times better than with the *S-20* surface. In addition to increased yield, the spectral threshold is also extended.

*ITT Industrial Laboratories
United States of America*

Doppler Aircraft Beacon—A comprehensive report has been issued by Eurocontrol on extensive tests made by the Bundesanstalt für Flugsicherung (German Federal Agency for Air Navigation) of the Doppler very-high-frequency omnidirectional beacon.* The test results have been very satisfactory and, in particular, the accuracy of azimuth measurements during flights over unfavorable terrain has been outstanding.

Recent Achievements

An electronic switch connects a transmitter sequentially to 39 antennas in a wide-aperture circle so that a circular motion of the radiation source is simulated. The resulting Doppler effect at the airborne receiver appears as a frequency modulation of the radiated signal. The phase of this frequency modulation varies with azimuth and is compared with a fixed-phase reference signal also radiated by the ground beacon. Although compatible with the new system, the conventional airborne very-high-frequency omnidirectional range receivers have such large instrumental errors that an attachment is required to obtain the full accuracy of the Doppler system.

*Standard Elektrik Lorenz
Germany*

Rocket Telemetry and Command Equipment—

A recoverable sounding rocket is being developed by Dornier System and other German companies for the space research program of that country. The rocket will lift scientific instruments up to about 80 kilometers (50 miles) and will return under controlled paraglider descent to a preselected landing area.

The airborne package contains 300 integrated semiconductor circuits welded to printed wiring boards. Pulse-code modulation is used for both telemetry and command. There are 16 channels for metering data and 2 channels for yes-no indications from 14 inputs. Additional channels and changes in sampling rates can be accommodated. Most telemetered data pertain to flight attitude, altitude, air speed, elevator and rudder positions, et cetera. The command section receives and evaluates instructions from the ground for elevator and rudder adjustments in addition to various yes-no commands such as for paraglider deployment and parachute ejection.

* V. F. Steiner, "Wide-Base Doppler Very-High-Frequency Direction Finder," *Electrical Communication*, volume 37, number 2, pages 135-146; 1961.

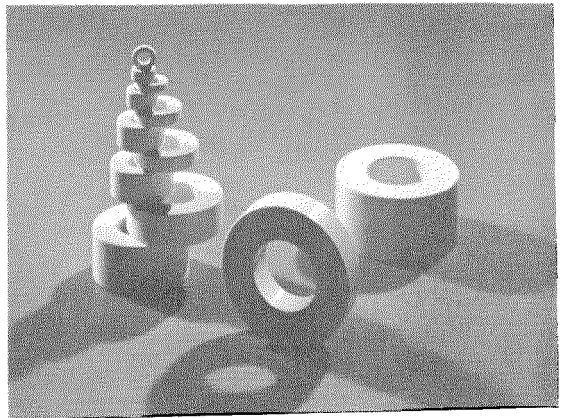

Figure 15—New range of ferrite ring cores.

The complete telemetry and command package including a direct-current converter for the power supply weighs only 1.7 kilograms (3.7 pounds).

*Standard Elektrik Lorenz
Germany*

Ferrite Ring Cores—The uniformly spaced range of ferrite ring cores shown in Figure 15 provides 2 heights of cores for each diameter, giving a 2:1 ratio of effective areas. This gives a choice of 2 cores with the same specific inductance or the same effective area over most of the range. The ratio of internal to external diameters of each core permits maximum inductance compatible with easy winding by hand or machine. Ferrite materials SA503 and SA601 are used.

*Standard Telephones and Cables
United Kingdom*

Instrument Landing at London Airport Upgraded—The British Ministry of Aviation has authorized suitably equipped aircraft to land at London Airport under Category II conditions defined by the International Civil Aviation Organization as runway visibility of 0.25 mile

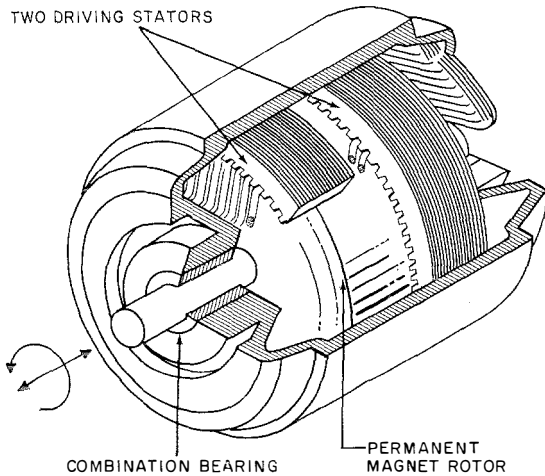

Figure 16—Motor producing shaft motion in 3 dimensions.

refractory material for reliability and long life. Electric-field stresses are minimized and hold-off voltages may be as high as 100 kilovolts. The capacities range from 200 to 4000 joules.

*ITT Electron Tube Division
United States of America*

Data Transmission Across Atlantic—The Cummings Engine Company now gathers its New York data from its European organization over the public telephone network and a transatlantic Datel circuit provided by ITT World Communications. Replacing telex, the *GH 205* data-transmission equipment provides speeds up to 940 words per minute. Operation is from paper tape punched on a teleprinter machine.

*Standard Telephones and Cables
United Kingdom*

Motor for Producing Motion in 3 Dimensions—

The shaft of the electric motor shown in Figure 16 will rotate in the conventional manner and also move in and out along its axis. The length of the axial stroke can be adjusted within broad limits and there can be between 1 and 32 such strokes per revolution. It need not rotate fully but can supply reciprocating action over 90, 180, or 360 degrees.

Using a permanent-magnet rotor and 2 stator windings, the motor is energized from pulsed direct current. Under certain conditions 60- or 400-hertz supply may be used. Sizes may range up to 5 horsepower.

Although originally designed for driving a compressor, the motor may drive cutting tools, mixers, precision winders, engravers, air circulators, and stitching machines.

*ITT Federal Laboratories
United States of America*

(0.4 kilometer) and cloudbase down to 100 feet (30 meters). This is the first airport in the world to attain Category II operation. Stan 7/8 instrument low-approach equipment is used at London Airport as at all major airports in the United Kingdom and at 21 international airports. It will soon be installed at Louis Botha Airport in Durban, Union of South Africa.

*Standard Telephones and Cables
United Kingdom*

Triggered Spark Gaps—A series of triggered spark gaps have been designed for discharging a power supply to prevent damage to equipment under fault conditions. These F810-F831 ceramic-metal gaps will operate over a wide temperature range without applying extra heat.

The gaps contain two primary high-power electrodes and a trigger electrode that is generally fired through a step-up transformer by a simple low-energy pulse. The electrodes are of special

International Telephone and Telegraph Corporation

Principal Divisions and Subsidiaries

NORTH AMERICA

MANUFACTURING—SALES —SERVICE

Canada

Barton Instruments Ltd. (Canada),
Calgary, Alta.
Cannon Electric (Canada) Ltd.,
Toronto, Ont.
General Controls Company (Can-
ada) Ltd., Guelph, Ont.
ITT Canada Limited, Montreal,
P.Q.
Royal Electric Company (Quebec)
Ltd., Pointe Claire, P.Q.
Wakefield Lighting Ltd. (Canada),
London, Ont.

Jamaica

ITT Standard Electric of Jamaica
Ltd., Yallahs

Mexico

ITT de México, S. A. de C. V.,
Mexico City
Industria de Telecomunicación,
S. A. de C. V., San Bartolo
Naucalpán
Industrias Ocelco de México,
S. A., Monterrey
Materiales de Telecomunica-
ción, S. A., Toluca
McClellan, S. A., Mexico City
Standard Eléctrica de México,
S. A., Mexico City
Wyatt de México, S. A. de C. V.,
Tlalnepantla

Panama

ITT Standard Electric of Panama,
S. A., Panama City

Puerto Rico

ITT Caribbean Manufacturing, Inc.,
Rio Piedras
ITT Caribbean Sales and Service,
Inc., Rio Piedras

United States

Documat Inc., Waltham, Mass.
Federal Electric Corporation, Pa-
ramus, N. J.
Intelix Systems Incorporated,
Paramus, N. J.
International Standard Engineer-
ing, Inc., Paramus, N. J.
ITT Technical Services Inc.,
Paramus, N. J.
International Standard Electric
Corporation, New York, N. Y.
International Telephone and Tele-
graph Corporation, Sud Amer-
ica, New York, N. Y.
ITT Arkansas Division, Camden,
Ark.
ITT Cannon Electric (division),
Los Angeles, Calif.

ITT Controls and Instruments Di-
vision, Glendale, Calif.

Barton Instrument Corporation,
Monterey Park, Calif.
General Controls, Glendale, Calif.
Hammel-Dahl, Warwick, R. I.
Henze Valve Service, Hoboken,
N. J.

ITT Data Services (division), Pa-
ramus, N. J.

ITT Electron Tube Division, Eas-
ton, Pa.

ITT Electro-Physics Laboratories
Inc., Hyattsville, Md.

ITT Environmental Products Divi-
sion, Philadelphia, Pa.
Nesbitt, Philadelphia, Pa.
Hayes, Torrance, Calif.

Norman, Columbus, Ohio
Reznor, Mercer, Pa.

ITT Export Corporation, New
York, N. Y.

ITT Farnsworth Research Cor-
poration, Fort Wayne, Ind.

ITT Federal Laboratories (divi-
sion), Nutley, N. J.

ITT Federal Support Services,
Richland, Wash.

ITT Fluid Handling Division, Mor-
ton Grove, Ill.

Bell & Gossett Hydronics, Mor-
ton Grove, Ill.

Marlow, Midland Park, N. J.
Stover, Freeport, Ill.

ITT Gilfillan Inc., Los Angeles,
Calif.

ITT Industrial Laboratories Divi-
sion, Fort Wayne, Ind.

ITT Industrial Products Division,
San Fernando, Calif.

ITT Industries, Inc., New York,
N. Y.

ITT Jabsco Inc., Costa Mesa, Calif.

ITT Mackay Marine (division),
Clark, N. J.

ITT Microwave Inc., Mountain-
view, Calif.

ITT Mobile Telephone, Inc., Bur-
bank, Calif.

ITT Semiconductors (division),
West Palm Beach, Fla., and
Lawrence, Mass.

ITT Telecommunications (divi-
sion), New York, N. Y.; Co-
rinth, Miss.; Milan, Tenn.;
Raleigh, N. C.

ITT Terryphone Corporation, Har-
risburg, Pa.

ITT Wakefield Corporation, De-
troit, Mich.

ITT Wire and Cable Division,
Pawtucket, R. I.

Royal, Pawtucket, R. I.

Surprenant, Clinton, Mass.

Jennings Radio Manufacturing Cor-
poration, San Jose, Calif.

TELEPHONE OPERATIONS

Puerto Rico

Puerto Rico Telephone Company,
San Juan

Virgin Islands

Virgin Islands Telephone Corpora-
tion, Charlotte Amalie

SOUTH AMERICA

MANUFACTURING—SALES —SERVICE

Argentina

Compañía Standard Electric Ar-
gentina, S. A. I. C., Buenos
Aires

Brazil

Standard Eléctrica, S. A., Rio de
Janeiro
Eletrônica Industrial
S. A., São Paulo

Chile

Compañía Standard Electric, S. A.
C., Santiago

Colombia

ITT Standard Electric de Colom-
bia, S. A., Bogotá

Ecuador

International Standard Electric of
New York Limited (branch),
Quito

El Salvador

International Standard Electric of
New York Limited (branch),
San Salvador

Venezuela

Standard Telecommunications C.
A., Caracas

TELEPHONE OPERATIONS

Brazil

Companhia Telefônica Nacional,
Curitiba

Chile

Compañía de Teléfonos de Chile,
Santiago

Peru

Compañía Peruana de Teléfonos
Limitada, Lima

EUROPE, MIDDLE EAST, AFRICA

MANUFACTURING—SALES —SERVICE

Algeria

Société Algérienne de Construc-
tions Téléphoniques, Algiers

Austria

Standard Telephon und Tele-
graphen Aktiengesellschaft,
Czeija, Nissl & Co., Vienna

International Telephone and Telegraph Corporation

Belgium

Bell Telephone Manufacturing Company, Antwerp
ITT Europe, Inc. (branch), Brussels
ITT Standard S. A. (branch), Brussels (Offices in several countries)

Denmark

Standard Electric Aktieselskab, Copenhagen

Finland

Standard Electric Puhelinteollisuus Oy, Helsinki

France

Cannon Electric France S.A., Toulouse and Paris
CFRO/SEDRE, Paris
Compagnie Générale de Constructions Téléphoniques, Paris
Les Téléimprimeurs, Paris
Compagnie Générale de Métrologie, Annecy
International Standard Engineering Inc. (branch), Paris
Laboratoire Central de Télécommunications, Paris
Le Matériel Technique Industriel, Paris
Le Matériel Téléphonique, Paris
Océanic-Radio, Paris and Chartres
Société des Produits Industriels ITT, Paris
Société Industrielle de Composants pour l'Électronique, Courbevoise

Germany

Deutsche ITT Industries G.m.b.H., Freiburg
Standard Elektrik Lorenz Aktiengesellschaft, Stuttgart
Graetz G.m.b.H., Stuttgart, and other subsidiaries

Greece

ITT Hellas A. E., Athens

Iran

Standard Electric Iran AG, Tehran

Italy

Fabbrica Apparecchiature per Comunicazioni Elettriche Standard S.p.A., Milan
Società Impianti Elettrici Telefonici Telegrafici e Costruzioni Edili S.p.A., Florence
ITT Domel Italiana S.p.A., Milan

Netherlands

Internationale Gas Apparaten N.V., Utrecht
Nederlandse Standard Electric Maatschappij N.V., The Hague

Nigeria

ITT Nigeria Limited, Lagos

Norway

Standard Telefon og Kabelfabrik A/S, Oslo

Portugal

Standard Eléctrica, S. A. R. L., Lisbon

Republic of South Africa

Standard Telephones and Cables (South Africa) (Proprietary) Limited, Boksburg East, Transvaal

Rhodesia

Supersonic Africa (Pty) Limited, Bulawayo

Spain

Compañía Internacional de Telecomunicación y Electrónica, S. A., Madrid
Compañía Radio Aérea Marítima Española, S. A., Madrid
Standard Eléctrica, S. A., Madrid

Sweden

ITT Norden AB, Solna
Standard Radio & Telefon AB, Barkarby

Switzerland

Intel S. A., Basle
ITT Standard S. A., Basle
Standard Téléphone et Radio S. A., Zurich
Müller-Barbieri AG, Wettswil
Steiner S. A., Berne

Turkey

Standard Elektrik ve Telekomünikasyon Limited Şirketi, Ankara

United Kingdom

Cannon Electric (Great Britain) Ltd., Basingstoke
Creed and Company Limited, Brighton
ITT Industries Limited, London
Maclaren Controls Limited, Glasgow, and other subsidiaries
Standard Telephones and Cables Limited, London
Standard Telecommunication Laboratories Limited, London, and other subsidiaries

Zambia

Supersonic Radio Zambia Limited, Livingstone

FAR EAST AND PACIFIC

MANUFACTURING—SALES—SERVICE

Australia

Cannon Electric (Australia) Pty. Limited (50% interest), Melbourne
Standard Telephones and Cables Pty. Limited, Sydney
ITT Australia Pty. Limited, Brisbane and other cities

Hong Kong

ITT Far East and Pacific, Inc. (branch), Hong Kong
ITT Far East Ltd., Hong Kong
Transelectronics, Limited, Hong Kong

India

ITT Far East and Pacific, Inc. (branch), New Delhi

Japan

ITT Far East and Pacific, Inc. (branch), Tokyo

New Zealand

Standard Telephones and Cables Pty. Limited (branch), Upper Hutt, Wellington

Philippines

Globe-Mackay Cable and Radio Corporation, Manila (Unit of ICO Group, below)
ITT Philippines, Incorporated, Makati, Rizal

INTERNATIONAL COMMUNICATIONS OPERATIONS

American Cable & Radio Corporation, New York
All America Cables and Radio, Inc.
Commercial Cable Company, The Globe-Mackay Cable and Radio Corporation
ITT All America Communications—Caribbean, Inc.
ITT Cable and Radio, Inc.—Puerto Rico
ITT Communications, Inc.—Virgin Islands
ITT World Communications Inc. Press Wireless, Inc.
Companhia Rádio Internacional do Brasil, Rio de Janeiro
Compañía Internacional de Radio Boliviana, La Paz
Compañía Internacional de Radio, S. A., Buenos Aires
Compañía Internacional de Radio, S. A., Santiago
Cuban American Telephone and Telegraph Company (50% interest), Havana
Radio Corporation of Cuba, Havana

FINANCIAL AND OTHER SERVICES

Alexander Hamilton Life Insurance Company, Denver, Colo.
American Universal Life Insurance Company, St. Louis, Mo.
Hamilton Management Corporation, Denver, Colo.
ISE Finance Holdings S. A., Luxembourg

International Telephone and Telegraph Corporation

ITT Avis, Inc., Garden City, N. Y.
ITT Financial Services Inc., New York, N. Y.
Great International Life Insurance Company (50% interest), Atlanta, Ga.
International Telephone and Telegraph Credit Corporation, New York, N. Y.
ITT Aetna Finance Company, St. Louis, Mo.
Kellogg Credit Corporation, New York, N. Y.

INTERESTS (minority and other) AND ASSOCIATE LICENSEES

Australia

Austral Standard Cables Pty. Limited, Melbourne

France

Lignes Télégraphiques et Téléphoniques, Paris

Italy

Società Italiana Reti Telefoniche Interurbane, Milan

Japan

Nippon Electric Company, Limited, Tokyo
Sumitomo Electric Industries, Limited, Osaka

Spain

Marconi Española, S. A., Madrid

THE WORLD OF ITT

North America*

47,000 employees
10,000,000 square feet

Europe, Middle East, Africa

135,000 employees
23,300,000 square feet

South America

13,500 employees
1,100,000 square feet

Far East and Pacific

3,500 employees
800,000 square feet

Totals

199,000 employees
35,200,000 square feet
Sales representatives in most countries

** Includes Central America and Caribbean*

Data Communication for Industry and Commerce
Three Data-Communication Systems
Modem Equipments Complying with International Standards
Modem Equipment for Parallel Data Transmission
Special Measuring Equipments for Data Transmission
Error Detection and Correction in Low-Speed Data-Transmission Equipment
Dynamic Measurements of Magnetic Thin Films
Memory for Test and Evaluation of Magnetic Thin Films
Data Transmission—Current Trends and Future Prospects
Instrument Low-Approach System and Radio Altimeter for All-Weather Landings

VOLUME 41 • NUMBER 2 • 1966